

Wilo-RainSystem AF 400



en Installation and operating instructions



RainSystem AF 400
<https://qr.wilo.com/534>

Fig. 1a

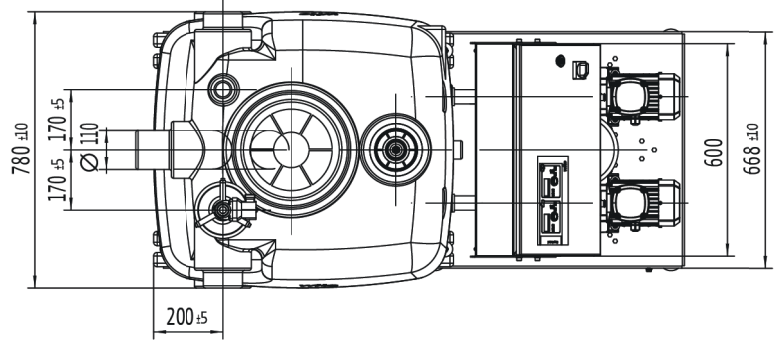
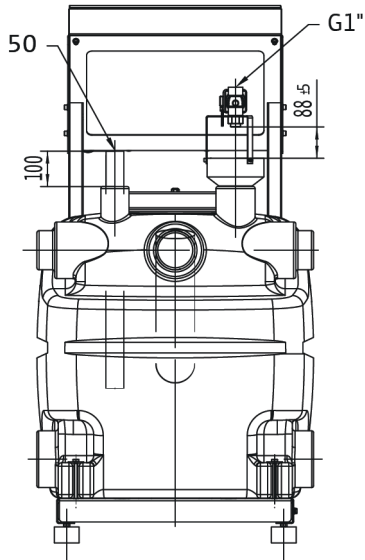
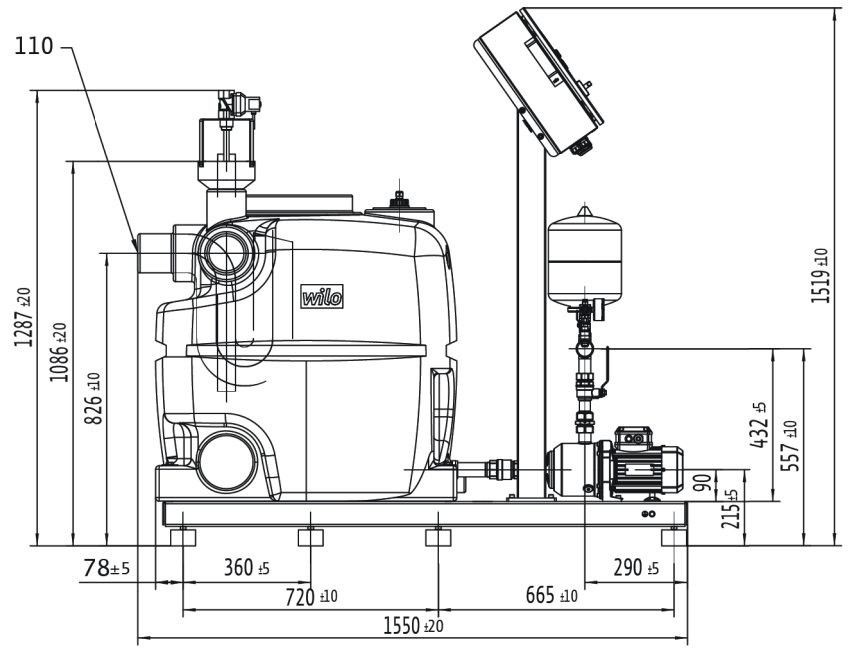
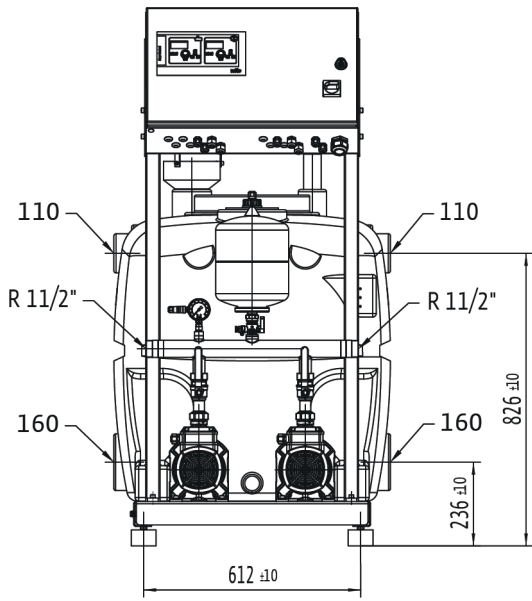

Fig. 1b

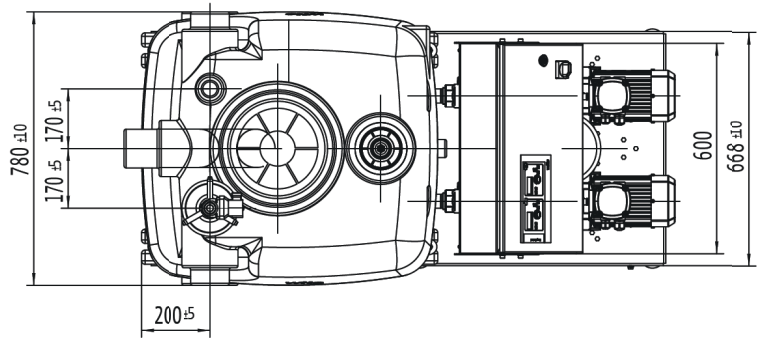
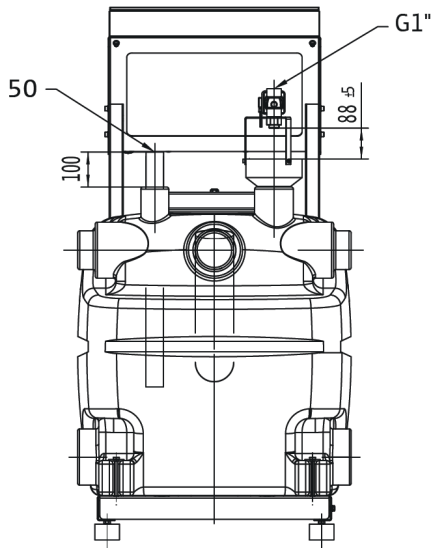
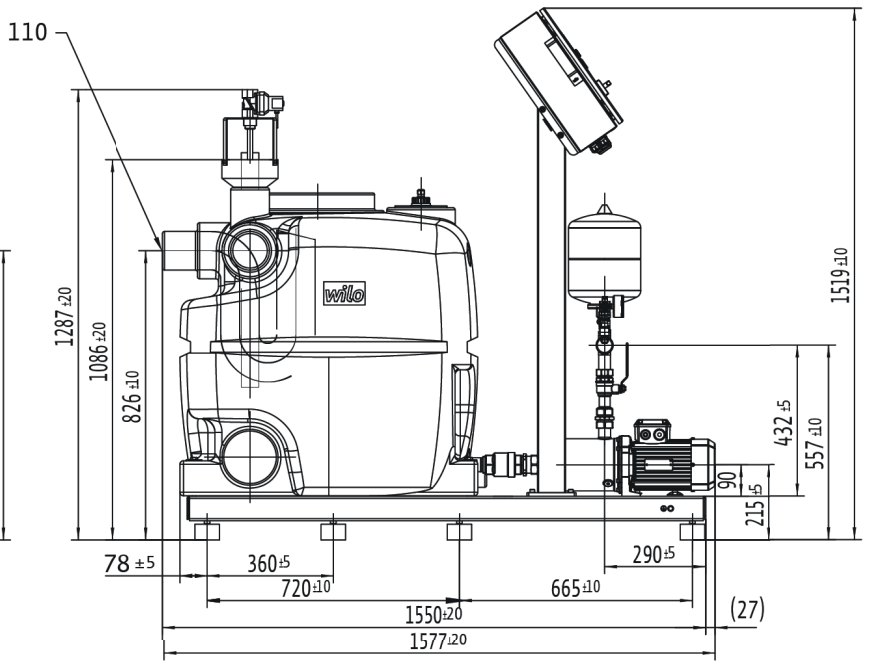
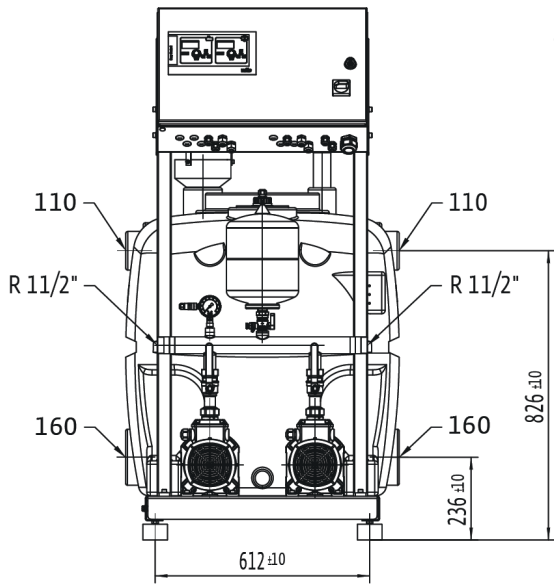

Fig. 2a

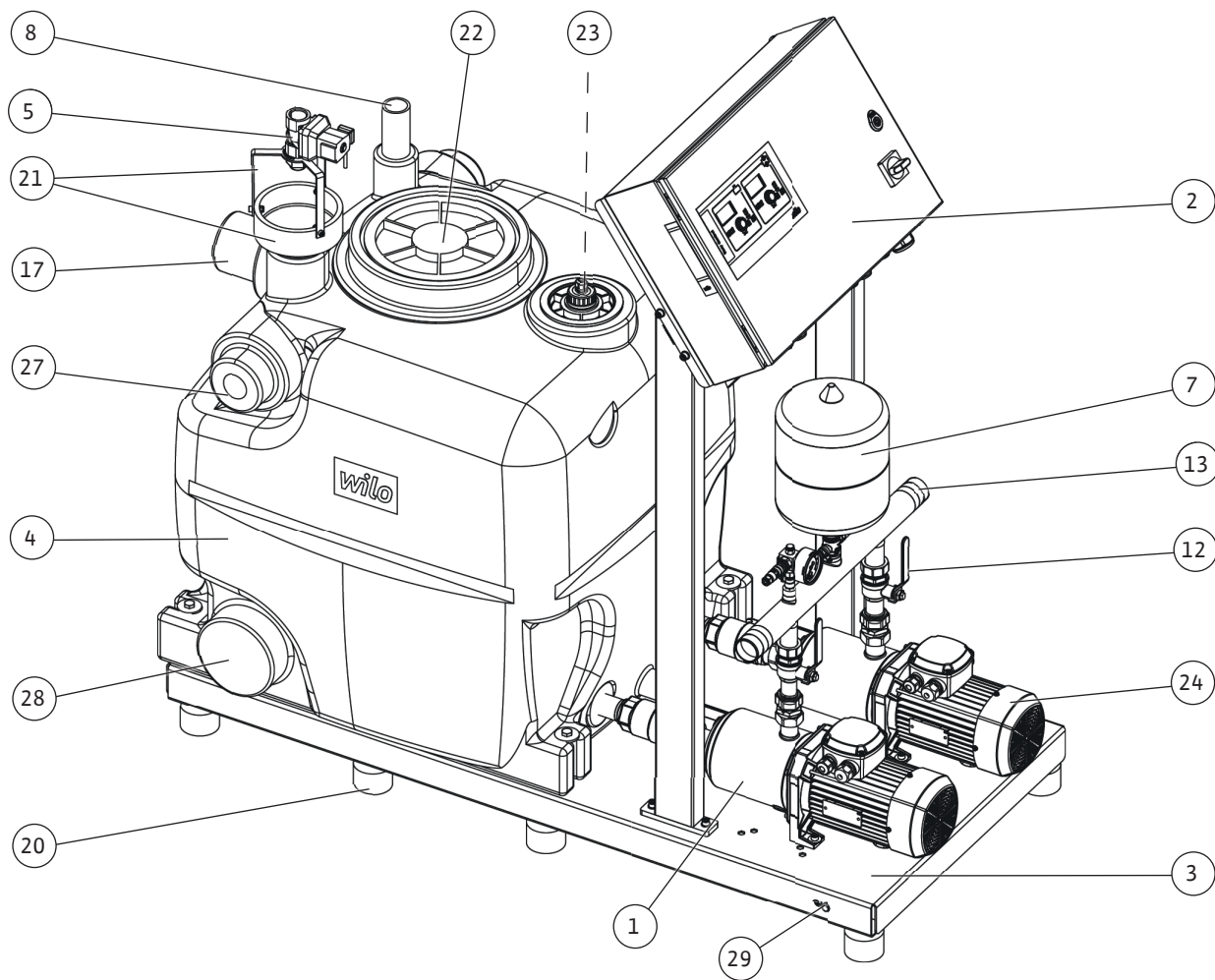

Fig. 2b

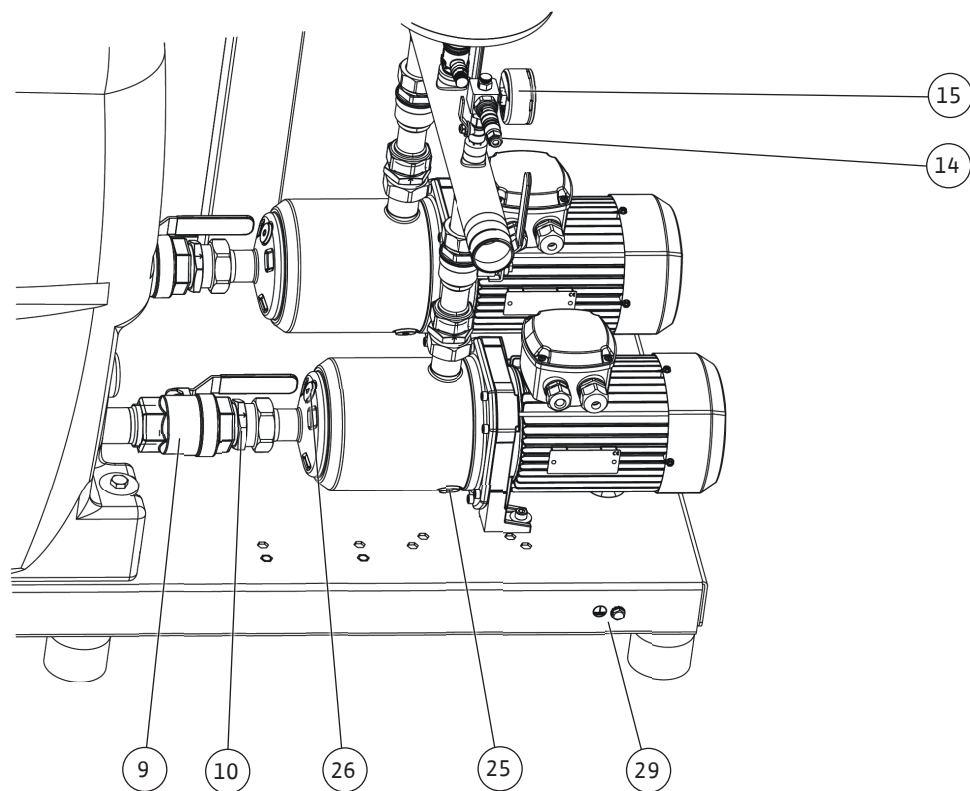

Fig. 3a

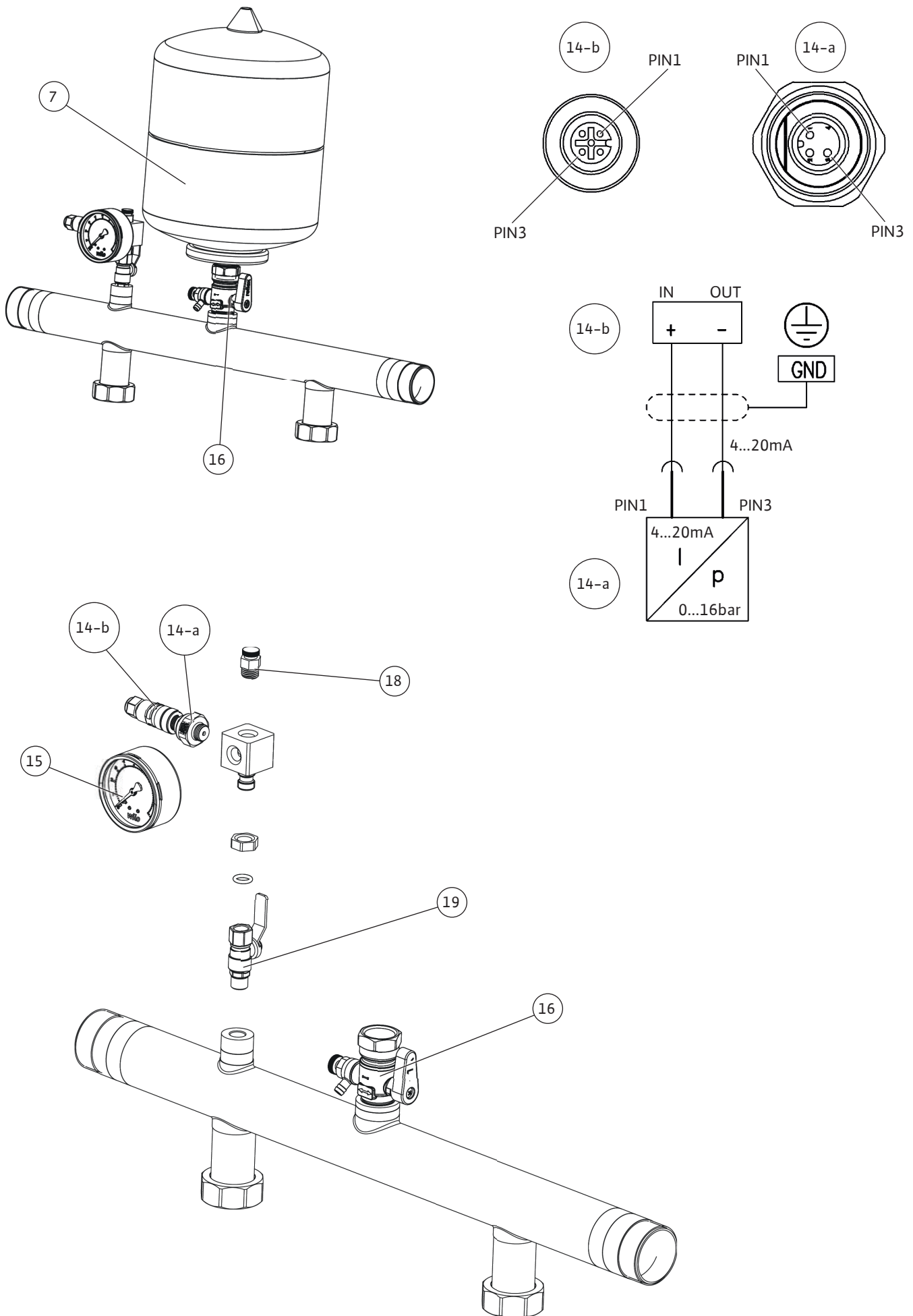

Fig. 3b

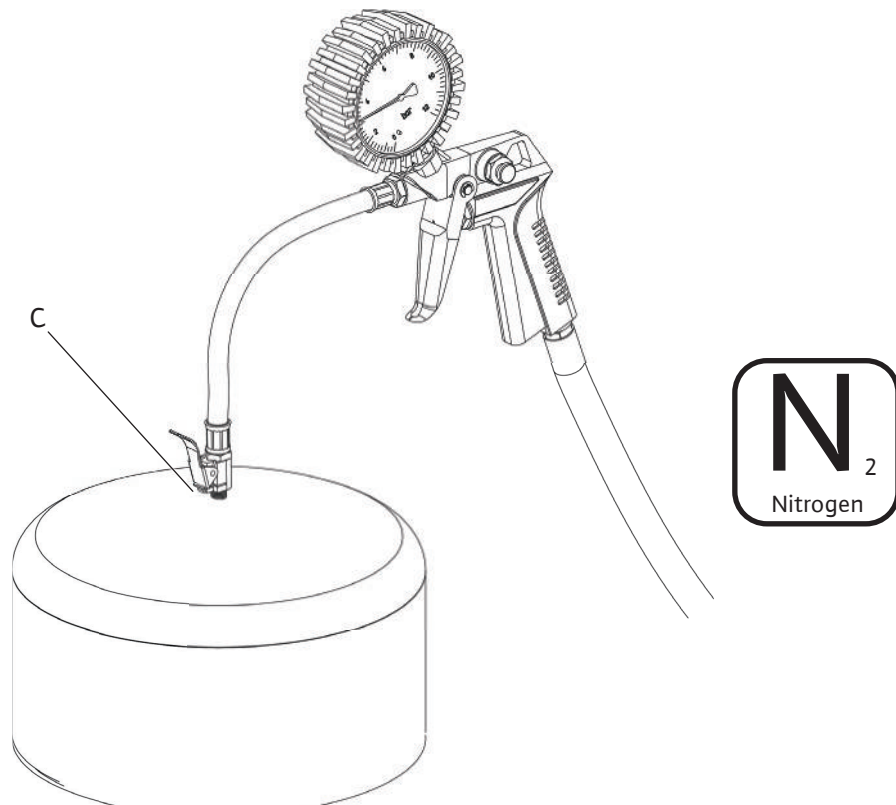
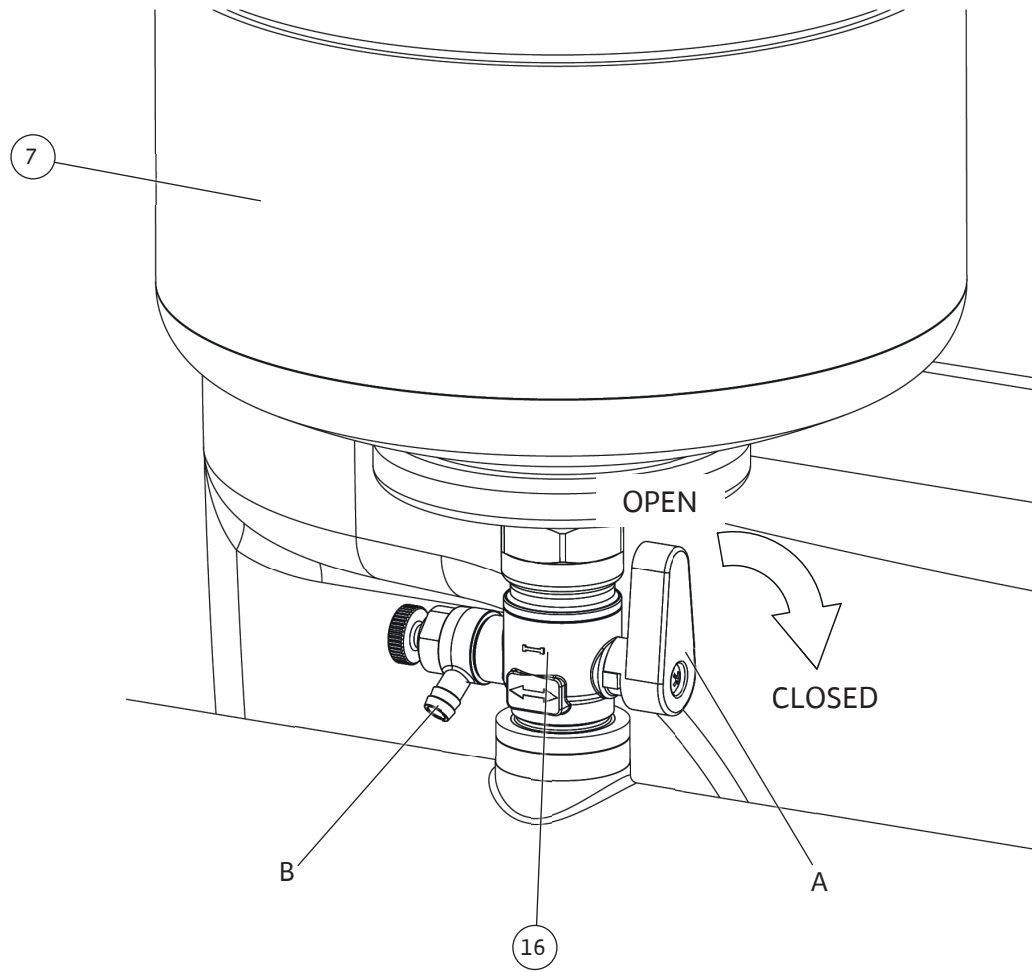

Fig. 4

Hinweis / advice / attention / atención

Stickstoffdruck entsprechend der Tabelle / Nitrogen pressure according to the table
 Pression d'azote conformément au tableau / Presión del nitrógeno según la tabla

PE [bar] Einschaltdruck / starting pressure / Pression de démarrage / Comenzar la presión

PN₂ [bar] Stickstoffdruck / Nitrogen pressure / Pression d'azote / Presión del nitrógeno

PE	2	2,5	3	3,5	4	4,5	5	5,5	6	6,5	7	7,5
PN ₂	1,8	2,3	2,8	3,2	3,7	4,2	4,7	5,2	5,7	6,1	6,6	7,1

PE	8	8,5	9	9,5	10	10,5	11	11,5	12	12,5	13	13,5
PN ₂	7,5	8	8,5	9	9,5	10	10,5	11	11,5	12	12,5	13

1bar = 100000Pa = 0,1MPa = 0,1N/mm² = 10200kp/m² = 1,02kp/cm²(at) = 0,987atm = 750Torr = 10,2mWs

Stickstoffmessung ohne Wasser / Nitrogen measurement without water /

Mesure d'azote sans l'eau / Medida del nitrógeno sin el agua

Achtung: Nur Stickstoff einfüllen / Note: Only fill in nitrogen /

Respect : Seulement l'azote remplir / Nota: Completar solamente el nitrógeno

Fig. 5

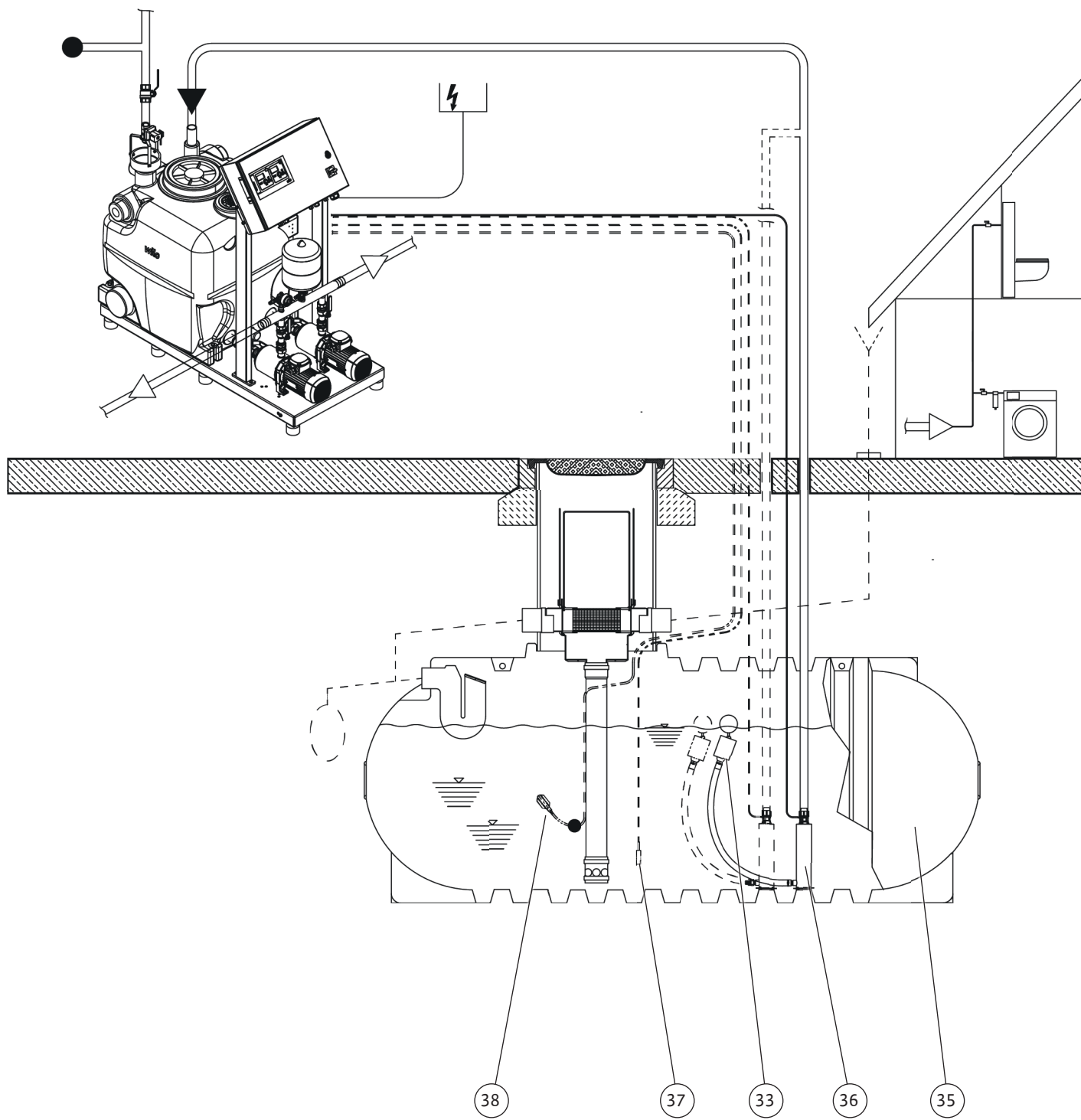

Fig. 6a

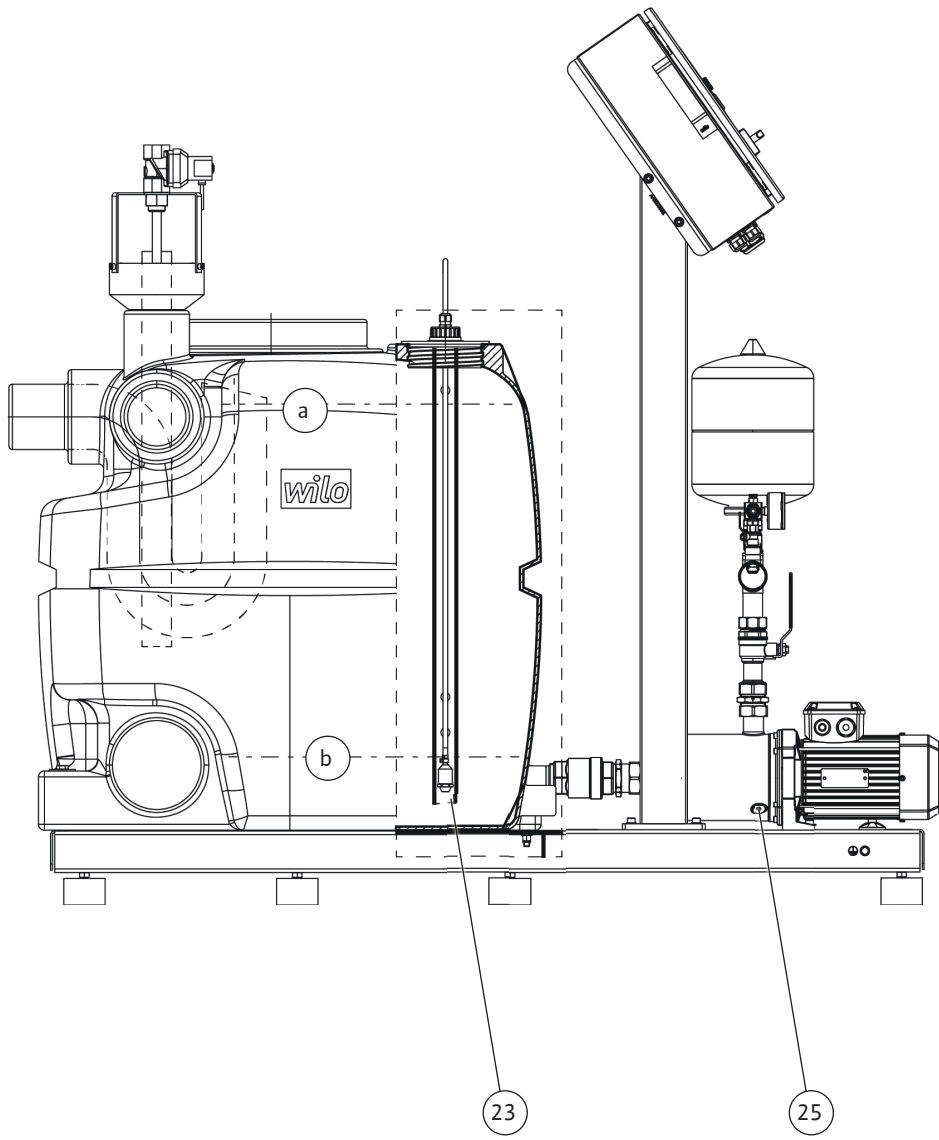

Fig. 6b

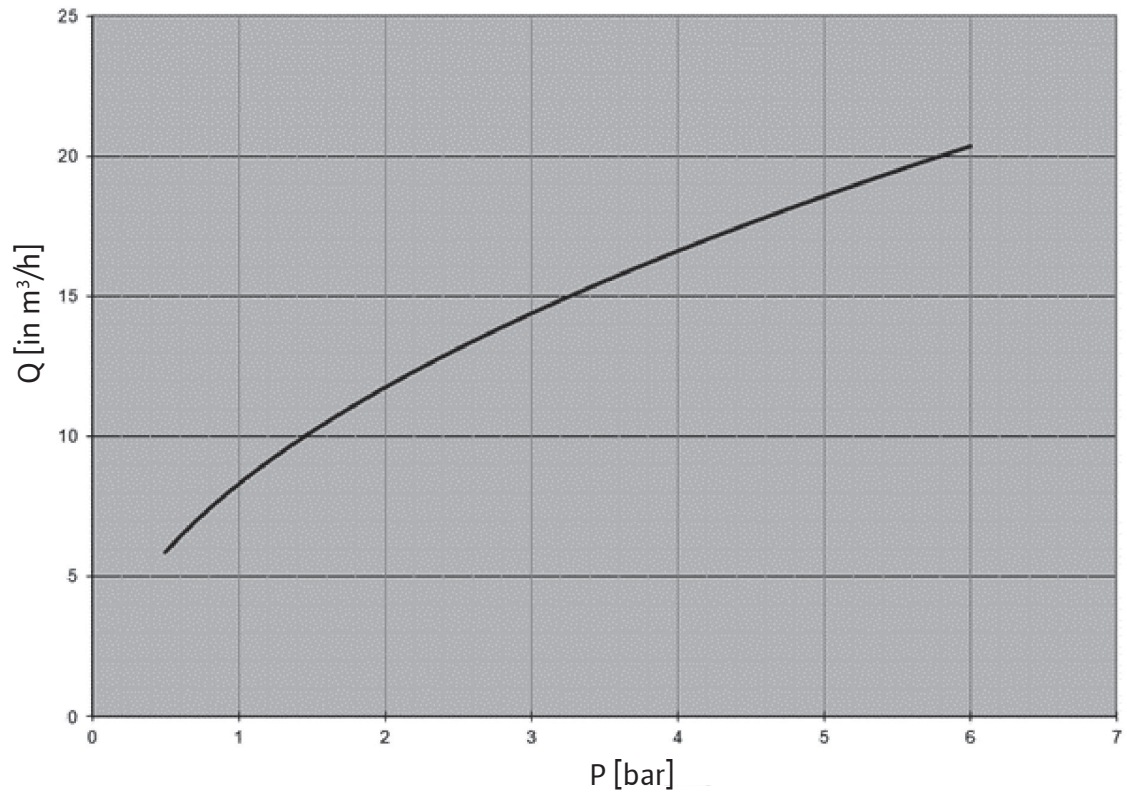



Table of contents

1	General	14
1.1	About these instructions	14
1.2	Copyright	14
1.3	Subject to change	14
1.4	Exclusion from warranty and liability.....	14
2	Safety	14
2.1	Identification of safety instructions	14
2.2	Personnel qualifications.....	15
2.3	Electrical work	16
2.4	Monitoring devices	16
2.5	Transport.....	16
2.6	Installing/dismantling.....	17
2.7	During operation.....	17
2.8	Maintenance tasks.....	17
2.9	Operator responsibilities	18
3	Application/use	18
3.1	Intended use.....	18
3.2	Improper use.....	19
4	Product description	19
4.1	Type key	19
4.2	Technical data	19
4.3	Scope of delivery.....	20
4.4	Accessories	20
4.5	Description of the system	20
4.6	Function	22
5	Transport and storage	23
5.1	Delivery.....	24
5.2	Transport.....	24
5.3	Storage	24
6	Installation and electrical connection	24
6.1	Installation location.....	25
6.2	Installation	25
6.3	Electrical connection.....	28
7	Commissioning	28
7.1	Preparations and control measures.....	29
7.2	Commissioning the system	31
8	Shutdown/dismantling	31
9	Maintenance	31
9.1	Tests of the rainwater utilisation system.....	31
9.2	Checking the supply pressure.....	31
10	Faults, causes and remedies	32
11	Spare parts	34
12	Disposal	34
12.1	Information on the collection of used electrical and electronic products.....	34
12.2	Batteries/rechargeable batteries	34
13	Appendix	35
13.1	Captions	35

1 General

1.1 About these instructions

These instructions form part of the product. Compliance with the instructions is essential for correct handling and use:

- Read the instructions carefully before all activities.
- Keep the instructions in an accessible place at all times.
- Observe all product specifications.
- Observe the markings on the product.

The language of the original operating instructions is German. All other languages of these instructions are translations of the original operating instructions.

1.2 Copyright

WILO SE © 2024

The reproduction, distribution and utilisation of this document in addition to communication of its contents to others without express consent is prohibited. Offenders will be held liable for payment of damages. All rights reserved.

1.3 Subject to change

Wilo shall reserve the right to change the listed data without notice and shall not be liable for technical inaccuracies and/or omissions. The illustrations used may differ from the original and are intended as an exemplary representation of the product.

1.4 Exclusion from warranty and liability

Wilo shall specifically not assume any warranty or liability in the following cases:

- Inadequate configuration due to inadequate or incorrect instructions by the operator or the client
- Non-compliance with these instructions
- Improper use
- Incorrect storage or transport
- Incorrect installation or dismantling
- Insufficient maintenance
- Unauthorised repairs
- Inadequate construction site
- Chemical, electrical or electrochemical influences
- Wear

2 Safety

This chapter contains basic information for the individual phases of the life cycle. Failure to observe this information carries the following risks:

- Injury to persons from electrical, mechanical and bacteriological factors as well as electromagnetic fields
- Environmental damage from discharge of hazardous substances
- Property damage
- Failure of important functions of the product

Failure to observe the information contained herein will result in the loss of claims for damages.

The instructions and safety instructions in the other chapters must also be observed!

2.1 Identification of safety instructions

These installation and operating instructions set out safety instructions for preventing personal injury and damage to property. These safety instructions are shown differently:

- Safety instructions relating to personal injury start with a signal word, are **preceded by a corresponding symbol** and are shaded in grey.



DANGER

Type and source of the danger!

Consequences of danger and instructions for avoidance.

- Safety instructions relating to property damage start with a signal word and are displayed **without** a symbol.

CAUTION

Type and source of the danger!

Consequences or information.

Signal words

- **DANGER!**
Failure to follow the instructions will result in serious injuries or death!
- **WARNING!**
Failure to follow the instructions can lead to (serious) injury!
- **CAUTION!**
Failure to follow the instructions can lead to potentially irreparable property damage as well as to total loss.
- **NOTICE!**
Useful information on handling the product

Markups

- ✓ Prerequisite
- 1. Work step/list
 - ⇒ Notice/instructions
 - ▶ Result

Symbols

These instructions use the following symbols:



General danger symbol



Danger caused by electric voltage



General warning symbol



Useful information

2.2 Personnel qualifications

- Personnel have been instructed on locally applicable regulations governing accident prevention.
- Personnel have read and understood the installation and operating instructions.
- Electrical work: qualified electrician

Person with appropriate technical training (according to EN 50110-1), knowledge and experience who can identify and prevent electrical hazards.

- Lifting work: trained specialist for the operation of lifting devices

Lifting equipment, lifting gear, attachment points

- Installation/dismantling must be carried out by a qualified technician who is trained in the use of the necessary tools and fixation materials.
- Operation/control: Operating personnel, instructed in the functioning of the complete system

2.3 Electrical work

- Observe applicable local regulations when connecting to the mains power supply.
- Comply with the requirements of the local energy supply company.
- Have electrical work carried out by a qualified electrician.
- Earth the device.
- Carry out the electrical connection according to the instructions of the switchgear and control device.
- Train personnel on how to make electrical connections.
- Train personnel on the options for switching off the device.
- Disconnect device from the mains and secure it against being switched on again without authorisation.
- Replace defective connection cables. Contact customer service.

2.4 Monitoring devices

The following monitoring devices must be provided on-site:

Circuit breaker

- Design the power and switching characteristics of the circuit breakers according to the rated current of the connected product.
- Observe local regulations.

Motor protection switch

- Instable mains supply systems: if necessary, install further protective devices on-site (e.g. overvoltage, undervoltage or phase failure relays, etc.).

Residual-current device (RCD)

- Install a residual-current device (RCD) in accordance with the regulations of the local energy supply company.
- If people can come into contact with the device and conductive fluids, install a residual-current device (RCD).

2.5 Transport

- Wear the following protective equipment:
 - Safety footwear
 - Safety helmet (when using lifting equipment)
- Locally applicable laws and regulations on work safety and accident prevention must be complied with.

- Only use legally prescribed and approved lifting and hoisting gear.
- Select the lifting gear based on the prevailing conditions (weather, attachment point, load, etc.).
- Always attach the lifting gear to the attachment points.
- Ensure that the lifting gear is securely attached.
- Ensure that the hoisting gear is stable.
- Ensure a second person is present to coordinate the procedure if required (e.g. if the operator's field of vision is blocked).
- Standing under suspended loads is not permitted. Do **not** move suspended loads over workplaces where people are present.

2.6 Installing/dismantling

- Wear the following protective equipment:
 - Safety footwear
 - Safety gloves for protection against cuts
- Locally applicable laws and regulations on work safety and accident prevention must be complied with.
- Disconnect device from the mains and secure it against being switched on again without authorisation.
- All rotating parts must stop.
- Clean the device thoroughly.

2.7 During operation

- Wear protective equipment according to work regulations.
- Demarcate and cordon off the working area.
- No persons are allowed in the working area during operation.
- Depending on the process, the product is activated and deactivated using separate controls. Product may automatically activate following power cuts.
- Superior must be informed immediately of any faults or irregularities.
- Operator must switch product off immediately if faults occur.
- Open all gate valves in the inlet and pressure pipe.
- Ensure protection against dry running.

2.8 Maintenance tasks

- Wear the following protective equipment:
 - Safety footwear
 - Safety gloves for protection against cuts
- Disconnect device from the mains and secure it against being switched on again without authorisation.
- Ensure cleanliness, dryness and good lighting in the work area.
- Only carry out maintenance tasks described in these installation and operating instructions.
- Only original parts of the manufacturer may be used. The use of any non-original parts releases the manufacturer from any liability.

2.9 Operator responsibilities

- Collect any leakage of fluid and operating fluid immediately and dispose of it according to the locally applicable guidelines.
- Clean the device thoroughly.
- Provide installation and operating instructions in a language which the personnel can understand.
- Make sure that the personnel have received the required training for the specified work.
- Provide protective equipment. Ensure that the protective equipment is worn by personnel.
- Ensure that safety and information signs mounted on the device are always legible.
- Train the personnel on how the system operates.
- Eliminate any risk from electrical current.
- Demarcate and cordon off the working area.
- Define a personnel work plan for safe workflow.
- Carry out a sound pressure measurement. From a sound-pressure level of 85 dB(A) upward, wear hearing protection. Include a note in the work regulations!

Observe the following points when handling the device:

- Use is not permitted for persons under the age of 16.
- Persons under the age of 18 must be supervised by a technician!
- Use is not permitted for persons with limited physical, sensory or mental capacities!

3 Application/use

3.1 Intended use

Function and application

The rainwater utilisation system is used for the fully automatic supply of rainwater from underground tanks or rainwater storage tanks in apartment blocks and public buildings. The system pumps rainwater or fresh water from the integrated hybrid tank. The control device regulates the on-site feeding pump in the rainwater storage tank to top up / fill up the hybrid tank with rainwater from an existing rainwater storage tank and automatically switches to top up the hybrid tank with fresh water if there is a shortage of rainwater.

The main applications are:

- Supply for toilet flushing.
- Washing water supply.
- Garden sprinkling and irrigation.

The integrated hybrid tank is prepared for indirect connection to the water mains. The connection is established using the solenoid valve of the hybrid tank using an air gap with unrestricted discharge according to EN 1717.

- Provide for soil drainage.

Current design, installation and application instructions for Wilo rainwater systems can be found in the Wilo design manual "Rainwater utilisation" and other Wilo manuals and brochures on pump and system technology, see: <https://wilo.com>.

For your safety

- Completely reading and following all instructions in these Installation and operating instructions.
- Observing the statutory accident prevention and environmental regulations.
- Complying with inspection and maintenance regulations.
- Complying with in-house regulations and instructions.

The rainwater utilisation system is built according to the manufacturer's specifications as well as the state of the art and the recognised safety regulations. However, in the event of incorrect operation or misuse, danger to life and limb of the operator or third parties or damage to the system itself and other material assets may occur.

The safety devices on the rainwater utilisation system are designed in such a way that there is no risk to the operating personnel when the system is used as intended.

The rainwater utilisation system may only be used in technically fault-free condition and in accordance with its intended use, in a safety-conscious and hazard-conscious manner and in compliance with these installation and operating instructions. Faults that may affect safety must be rectified immediately by qualified personnel.

3.2 Improper use

Possible misuse

The rainwater utilisation system is not designed for applications that are not explicitly intended for it by the manufacturer. This includes, in particular:

- Pumping fluids that chemically or mechanically attack the materials used in the system
- Pumping fluids that contain abrasive or long-fibre components
- Pumping fluids that are not intended for this purpose by the manufacturer

Persons under the influence of intoxicating substances (e.g. alcohol, drugs, narcotics) are not authorised to operate, maintain or modify the rainwater utilisation system in any way.

Improper use

Improper use occurs when parts other than those specified in the intended use are processed in the rainwater utilisation system. Modification of the components of the rainwater utilisation system also leads to improper use.

All spare parts must comply with the technical requirements specified by the manufacturer. There is no guarantee that third-party parts are designed and manufactured in accordance with appropriate safety and operational requirements. This is always guaranteed when using original spare parts.

Modifications to the rainwater utilisation system (mechanical or electrical changes to the function sequence) invalidate any liability on the part of the manufacturer for any resulting damage. This also applies to the installation and adjustment of safety devices and valves as well as the modification of load-bearing parts.

4 Product description

4.1 Type key

Example	Wilo-RainSystem AF 400-2Medana L405/EC2+1
Wilo	Brand name
RainSystem	System for rainwater utilisation for commercial use
AF	Series (Aqua Feed)
150	Hybrid tank volume (litres)
2	Number of pumps
Medana L	Pump series
4	Rated volume flow per pump Q [m ³ /h]
05	Number of pump stages
EC	EC control device (Easy Control)
2+1	Number of water supply pumps: 2 ; number of controlled feeding pumps:1

4.2 Technical data

Mains voltage	3~ 400 V ±10% (L1, L2, L3, N, PE)
Mains frequency	50 Hz
Power consumption	See rating plate
Rated current	See rating plate
Insulation class	F
Protection class	IP54
Electrical connection	See installation and operating instructions and circuit diagram of the control device

Max. volume flow	See rating plate and catalogue/data sheet
Max. delivery head	See rating plate and catalogue/data sheet
Max. operating pressure	10 bar
Start-up pressure for pump	variably adjustable, standard at 90% of the duty point
Ambient temperature	+5 °C – +40 °C
Motor protection	Integrated motor protection switch
Fluid temperature	+5 °C – +35 °C
Dimensions	See Fig. 1
Discharge port	R1 ½ (EN 10226-1)
Hybrid tank	400 litres (EN 1717, type AA air gap with unrestricted discharge)
Tap water connection	Female thread G1 (EN 228-1)
Connection to rainwater storage tank feed line	PE pipe, outer diameter 50 mm
Overflow connection	DN 100 / outer diameter Ø 110 with overflow syphon
Sound pressure level	55–56 dB(A) with one pump or 58–59 dB(A) with two pumps (Noise characteristics [► 22])
Diaphragm expansion tank	8 litres
Filling level sensor of the hybrid tank	Measurement range from 0 to 1 m
Mains voltage of feeding pump	3~400 V ±10% V (L1, L2, L3, N, PE) 50 Hz

4.3 Scope of delivery

- Rainwater utilisation system
- Diaphragm expansion tank
- Installation and operating instructions
- Box with accessories/accessories kit/add-on parts, if applicable

4.4 Accessories

Accessories must be ordered separately as required. The accessories from the Wilo range include the following:

- Feeding pump for installation in the rainwater storage tank
- Float switch for installation in the rainwater storage tank
- Filling level sensor for installation in the rainwater storage tank
- Special IP65 terminal box (pressure compensation box) with pressure compensation for indirect connection of the cable for the fill level sensor in the rainwater storage tank
- Larger diaphragm expansion tank (on the end pressure side)
- Floating coarse suction filter GR with integrated non-return valve for the feeding pump
- Floating fine suction filter FR with integrated non-return valve for the feeding pump

4.5 Description of the system



NOTICE

These installation and operating instructions contain a general description of the complete system.



NOTICE

For detailed information about the pumps and the control device in this rainwater utilisation system, see the enclosed installation and operating instructions.

- See Fig. 2a, 2b, 5

The system is designed as a water-supply unit with two non-self-priming pumps (Item 1) as a compact module. The pumps operate in alternating operation or for peak demand in parallel operation. The pumps receive incoming water from the hybrid tank (Item 4).

The control device (Item 2) ensures water supply according to demand with the help of a pressure transmitter (Item 14) in the discharge manifold (Item 13).

The control device (Item 2) monitors the water level in the hybrid tank with the aid of the filling level sensor (Fig. 6a, Item 23) mounted in the hybrid tank (Item 4) and ensures the tank is refilled from the rainwater storage tank by activating the feeding pump installed in it (Fig. 5, Item 36). If the fill level in the hybrid tank falls below the required level because it is not being adequately topped up by the rainwater storage tank or because a high amount of water is needed, the control device uses fresh water to top up / fill up the hybrid tank by opening the solenoid valve (Item 5).

A flow-through diaphragm expansion tank (8 litres) (Item 7) prevents the pumps from being switched on repeatedly in the event of small consumption or minor leakage.

4.5.1 Connection

Feed line ◀ (Fig. 5)

- Attach the feed line from the rainwater storage tank to the connection port (Item 8) of the hybrid tank.

Solenoid valve

- Connect the solenoid valve (Item 5) at the hybrid tank (Item 4) directly to the water mains (● Fig. 5).
- Install the connection so that it is without tension.

It is recommended to install a shut-off valve between the water mains inlet and the solenoid valve. Leaked water from the solenoid valve is drained via the overflow (Ø 110; Item 17) of the replenishment reservoir.

If the overflow is blocked, the water above the funnel (Item 21) will leak unhindered (protection of drinking water according to EN 1717).

- Provide for soil drainage.
- Consumers are connected via the discharge line ◀ (Fig. 5)
- Connect the overflow of the hybrid tank (Item 17) to the sewer system.
- See Fig. 2a, 2b, 5.

4.5.2 Components of the rainwater utilisation system

The complete system is made up of various main components.



NOTICE

Observe the respective installation and operating instructions for the individual component.

Mechanical and hydraulic components

The system is installed on a base frame (Item 3) with vibration absorbers (Item 20). It consists of two high-pressure multistage centrifugal pumps (Item 1) with a shut-off valve (Item 12) mounted on the discharge side. In addition, a lockable assembly with pressure transmitter (Item 14) and pressure gauge (Item 15) as well as an 8-litre diaphragm expansion tank (Item 7) with a lockable throughflow fitting (Fig. 3a, 3b, Item 16) are mounted on the common discharge line (Item 13).

A non-return valve (Item 10) and a shut-off valve (Item 9) are mounted on the inlet side of each pump and are connected by means of a pipe section to the hybrid tank (Item 4) mounted on the base frame.

The hybrid tank (Item 4) is a break tank that is fed with rainwater from the rainwater storage tank via the feed line ◀ (Fig. 5) as well as with fresh water ● (Fig. 5) via the solenoid valve (Item 5).

Filling level sensor in the hybrid tank

The filling level sensor mounted in the hybrid tank (Fig. 6a, Item 23) measures the fill level above the sensor and transmits this fill level as a current value to the control device.

High-pressure multistage centrifugal pump (Item 1):



NOTICE

Detailed instructions for the pump can be found in the enclosed installation and operating instructions for the pump.

Diaphragm expansion tank kit (Fig. 3b)

Consisting of:

- Diaphragm expansion tank (Item 7) with lockable throughflow fitting (Item 16) and drain valve.

Pressure transmitter kit on the discharge side (Fig. 3a)

Consisting of:

- Pressure gauge (Item 15)
- Pressure transmitter (Item 14a)
- Electrical connection, pressure transmitter (Item 14b)
- Drain/venting (Item 18)
- Stop valve (Item 19)

Control device (Fig. 2a, Item 2)

The control device is used to control and regulate the rainwater utilisation system. The control device regulates the rainwater storage tank pump(s) and the solenoid valve for the fresh water replenishment. The control device ensures the pressure-dependent activation or deactivation of the 2 pumps.



NOTICE

- See enclosed installation and operating instructions for the control device.

4.5.3 Noise characteristics

In the following overview, pumps of the standard series without a frequency converter are taken into account at a mains frequency of 50 Hz:

	Number of pumps	Rated power (kW)			
		0.55	0.75	1.1	1.5
Max. sound-pressure level (*)	1	55	55	56	56
LpA in [dB(A)]	2	58	58	59	59

(*) Values for 50 Hz (constant speed) with a tolerance of +3 dB(A)

LpA = workplace-related emission level in dB(A);

4.6 Function

CAUTION

Risk of damage to property!

Dry running can lead to the pump developing leakages and to motor overload.

- Ensure that the pump does not run dry to protect the mechanical seal and the plain bearings.

4.6.1 Description

The rainwater utilisation system with non-self-priming, horizontally installed, high-pressure multistage centrifugal pumps is supplied as a compact unit, fully piped and ready for connection.

- Make the following connections:
 - Fresh water inlet pipe (● Fig. 5) at the replenishment valve
 - Feed line (◀ Fig. 5) on the hybrid tank
 - Discharge line (◁ Fig. 5) to the consumer
 - Electrical mains connection
- Install the optional filling level sensor (Fig. 5, Item 37) or float switch (Fig. 5, Item 39) in the on-site rainwater storage tank and connect to the control device.
- Connect the on-site feeding pump to the control device.

The pumps are switched off when ready for operation and the taps are closed. When you open a tap, the pressure in the system drops. When the start-up pressure is reached, the first pump switches on. If the set pressure is not reached within an adjustable time, the second pump is switched on. After the tap is closed, the pressure rises and the pumps are switched off one after the other. All system statuses and fault messages in connection with the fill level and pressure detection are shown on the display of the control device.

4.6.2 Level control device in the hybrid tank and fill level indicator

Whether the hybrid tank is filled by the rainwater storage tank or the water mains is determined by a control procedure according to the fill level and system status.

The fill level in the hybrid tank is measured by the installed filling level sensor (Fig. 6a, Item 23).

The fill level is indicated on the control device display in metres (0.01 m = 1 cm), measured from the sensor installation height.

The menu parameters “Switchover to fresh water ON” and “Switchover to rainwater” or “Fresh water OFF” determine whether the hybrid tank is filled via the rainwater storage tank or water mains.



NOTICE

- See enclosed installation and operating instructions for the control device.

4.6.3 Further functions of the control device

The control device uses the pressure sensor to monitor the system. The control device switches the pumps on or off in sequence depending on the water demand of the system.

If the pressure in the system drops below the start-up pressure level when the system is ready for operation by opening a tap, the control device switches on the base-load pump.

If the pressure falls back to the start-up pressure level due to increasing water demand, the peak-load pump switches on.

As the water demand decreases, the pressure in the system increases. When the first switch-off pressure level is reached, the peak-load pump switches off (delay time as parameter). To avoid flutter, the peak-load pump is switched on and off with a time delay. The base-load pump only switches off at a higher pressure (deactivation threshold as parameter). The follow-up time of the base-load pump is also adjustable.

As fuse protection against motor overload, the trigger value must be defined as a menu parameter for each motor.

It is possible to connect a filling level sensor or a float switch to the control device to monitor the fill level of the rainwater storage tank in order to deactivate the feeding pump in the rainwater storage tank if the water level is too low.

Other functions such as protection against low water level or low pressure, water shortage pressure delay, pump replacement and manual/automatic operating mode can be set or selected as menu parameters on the control device.



NOTICE

- See enclosed installation and operating instructions for the control device.

5 Transport and storage



WARNING

Risk of injury from a lack of protective equipment!

Danger of (serious) injuries during work.

- Wear protective gloves to protect against cuts.
- Wear safety shoes.
- If lifting accessories are used, wear a safety helmet.



WARNING

Risk of injury from falling parts!

Never allow anyone to stand under suspended loads!

- Do not move the load over workplaces where persons are present.

CAUTION

Risk of damage to property!

Unsuitable lifting gear can cause the system to slip out or fall down.

- Only use suitable and approved lifting gear.
 - Never attach the lifting gear to the piping. Use the base frame for fixation.
-

CAUTION

Risk of damage to property due to incorrect loads!

Subjecting the pipes and valves to loads while in transit can result in leakages.

CAUTION

Risk of damage to property due to environmental influences!

The system can be damaged by environmental influences.

- Take suitable measures to protect the system from moisture, frost and heat as well as mechanical damage.
-



NOTICE

- After removing the packaging, store or assemble the system in accordance with the installation conditions described (see Chapter Installation and electrical connection [► 24]).
-

5.1 Delivery

The rainwater utilisation system is delivered mounted on a pallet. The rainwater utilisation system is protected from moisture and dust by foil.

- Observe transport and storage instructions attached to the packaging.
- The transport dimensions, weights, necessary passageways and transport areas of the system can be found on the supplied installation plan or documentation.
- On delivery and before unpacking the rainwater utilisation system and the accessories supplied, check the packaging for damage.

If damage is detected due to a fall or similar:

- Check the rainwater utilisation system and accessories for possible damage.
- Notify the delivery company (forwarding agent) or customer service, even if you do not find any obvious damage to the rainwater utilisation system or its accessories.

5.2 Transport

- If the outer packaging is damaged or no longer present, apply suitable protection from humidity and dirt.
- Do not remove the outer packaging until you are at the installation site.
- If the system is transported again at a later date, fit new suitable protection against moisture and contamination.
- Demarcate and cordon off the working area.
- Keep unauthorised persons away from the working area.
- Use approved lifting slings.

5.3 Storage

- Place the system on a firm and even surface.
- Ambient conditions: 10 °C to 40 °C, max. humidity: 50 %.
- Dry hydraulics and pipework before packing.
- Protect the system from humidity and dirt.
- Protect the system from direct exposure to sunlight.

6 Installation and electrical connection



WARNING

Risk of damage to your health!

Risk of damage to your health due to contaminated drinking water.

- When connecting the solenoid valve of the hybrid tank to the water mains, do not use any materials that could impair the quality of the water.
- Carry out a flushing of the above-mentioned connection pipe in order to minimise any impairment of the quality of the drinking water.
- Replace the water in the hybrid tank if the system is not used for a longer period of time.

6.1 Installation location

Requirements for the installation location:

- Dry, well ventilated and frost-resistant. The system is not designed for outdoor installation.
 - Sufficiently sized floor drainage (with sewer connection). Floor drainage is absolutely essential due to the hybrid tank.
 - Free of harmful gases and secured against gas ingress.
 - Maximum ambient temperature of +0 °C to 40 °C at a relative humidity of 50 %.
 - Horizontal and level installation surface.
 - Slight height adjustment for stabilisation possible with the vibration absorbers in the base frame (Fig. 2, Item 20):
1. Loosen the counter nut.
 2. Turn the appropriate vibration absorber out or in.
 3. Fix the counter nut again.

Also note:

- Ensure adequate space for maintenance work. Refer to the main dimensions (Fig. 1) or the supplied installation plan. The system should be freely accessible from at least two sides.
- Wilo advises against installation and operation near living rooms and bedrooms.
- To avoid the transmission of structure-borne noise and to ensure a stress-free connection to upstream and downstream pipes, use compensators with extension limiters or flexible connection pipes.

6.2 Installation



DANGER

Danger of death due to electrical current!

Improper conduct when carrying out electrical work can lead to death due to electric shock!

- Only have electrical connection established by an electrician approved by the local energy supply company.
- Observe applicable local regulations.
- Before swapping the phases, switch off the main switch of the system and secure it against unauthorised restarting.

6.2.1 Foundation/bearing surface

The rainwater utilisation system is designed for installation on a flat concrete floor. The base frame is mounted on height-adjustable vibration absorbers as means of insulation against structure-borne noise.



NOTICE

For transport reasons, the vibration absorbers may not be installed upon delivery. Before installing the rainwater utilisation system, check that all the vibration absorbers are fitted and locked by the threaded nut.

CAUTION**Risk of damage to property due to dust caps or plugs not removed!**

Dust caps or plugs that have not been removed can cause clogging and damage the pump.

- Check all connections and remove any remaining leftover packaging, dust caps and plugs.

- See Fig. 2a, 2b, 5.
- When connecting the solenoid valve of the hybrid tank to the water mains, do not use any materials that could impair the quality of the water.

Installation notes:

- On-site piping installation must be completed voltage-free.
- To avoid distortion of the pipe adaptors, use compensators with length limitation or flexible connection pipes. This minimises the transmission of system oscillations to the building installation.
- Absorb piping forces and do not transfer them to the system connections.

Feed line from the rainwater storage tank ◀ (Fig. 5)

- The connection port (Item 8) is located on the top of the tank (ø 50, 100 mm long, material PE) and can be connected to the feed line from the rainwater storage tank using standard connections (e.g. clamp bolting).

**NOTICE**

The feed volume from the rainwater storage tank must not exceed 16 m³/h (a throttle valve may have to be installed).

- Provide non-return valves in the feed line to prevent the system from draining into the rainwater storage tank.

CAUTION**Risk of damage to property due to flooding!**

Water can run out of the rainwater storage tank in an uncontrolled manner via the feed pipe due to the lifting effect.

- Check pipework routing and retrofit a vacuum relief valve in the ascending pipe of the feed pipe if necessary.

**NOTICE****Lifting effect**

If the water level in the rainwater storage tank is higher than that in the hybrid tank, the water may continue to flow from the rainwater storage tank into the hybrid tank when the feeding pump is switched off.

- Avoid this lifting effect by installing a vacuum relief valve in the ascending pipe of the feed line.



NOTICE

Water keeps running

If the feed line is very long and runs almost horizontally or slightly downwards to the hybrid tank, the water in feed line will empty into the hybrid tank after the feeding pump is switched off.

- Reduce the switching threshold for switching off the pump or install an electrically operated control valve upstream of the port for the feed line.

Connection of the fresh water replenishment ● (Fig. 5)

- For automatic replenishment, install a 1" replenishment pipe from the water mains to the system. The connection is made to the solenoid valve (female thread G1" on the top of the hybrid tank (Fig. 2b, Item 5))
- Mount the line to the solenoid valve via a discharge pipe in such a way that the discharge remains positioned directly above the suction cone of the tank. Unrestricted discharge (type AA) is ensured in the installation.
- Connect to the water mains in such a way that the supply line is continuously flushed or automatically flushed.
- It is recommended to install a throttle valve in the on-site replenishment line in order to avoid higher mains pressures and thus pressure surges at the solenoid valve as well as spraying from the funnel.

Overflow connection

- Connect the DN 100 overflow (Fig. 2a, Item 17) with an overflow syphon as anti-syphon trap and full passage in accordance with DIN 1986 (outer ϕ 110 mm, 100 mm long, material PE) to the sewer system using HT, KG or other waste water pipes.
- The overflow (Fig. 2a, Item 21) in accordance with EN 1717 is designed so that in the event of an accident, the overflowing water is clearly visible and can escape from the tank unhindered. Provide a floor drainage system for this purpose.

Discharge line ◁ (Fig. 5)

- A pipe connection with an R 1½" male thread is available on the right or left side of the system for connecting the discharge line. Close the connection that is not required using the cap supplied or a standard seal cap (pressure class PN 10).



NOTICE

Keep the flow resistance of the inlet and suction line as low as possible by means of the following:

- Short, horizontal piping if possible.
- Correct nominal diameter (at least same size as system connection).
- Minimal bends.
- Sufficiently large shut-off valves.
- Avoidance of automatic air vents.

6.2.3 Install accessories

Fitting the diaphragm expansion tank



NOTICE

Regular tests are required for diaphragm pressure expansion tanks in accordance with Directive 2014/68/EU (in Germany, also taking into account the Industrial Safety Regulation §§ 15(5) and 17 as well as Annex 5).

The diaphragm expansion tank (8 litres) included in the scope of delivery is supplied disassembled as an accessories kit for transportation and hygienic reasons.

- Mount the diaphragm expansion tank (Item 7) on the throughflow fitting (Item 16) before commissioning (Fig. 2a, 2b, 3a, 3b).

**NOTICE**

- Do not twist the throughflow fitting. The fitting is installed correctly when the drain valve (Fig. 3b, Item B) or the flow direction arrows printed on it are parallel to the pipe.

**NOTICE**

Observe the respective manufacturer's documentation for the component.

6.3 Electrical connection**DANGER****Danger of death due to electrical current!**

Improper conduct when carrying out electrical work can lead to death due to electric shock!

- Only have electrical connection established by an electrician approved by the local energy supply company.
- Observe applicable local regulations.
- Before swapping the phases, switch off the main switch of the system and secure it against unauthorised restarting.

**NOTICE**

- For the electrical connection, observe the relevant installation and operating instructions for the control device.
- Observe the enclosed electrical circuit diagrams.

Points to be taken into account:

- Technical electrical current type, voltage and frequency of the power supply network must match the details on the rating plate of the control device and the pumps.
- Sufficiently dimension the electrical connection cable according to the total power of the rainwater utilisation system (see rating plate, installation and operating instructions and enclosed electrical circuit diagrams).
- External fuse protection of the connection cable for the rainwater utilisation system must be provided in accordance with the applicable local regulations (e.g. VDE0100, part 430) in compliance with the details in the installation and operating instructions.

**NOTICE**

- Observe the associated installation and operating instructions and the enclosed electrical circuit diagrams.

Connection of optional components (Fig. 5)

- A filling level sensor (Item 37) (24 V, measuring signal 4 to 20 mA) can be connected to the control device for monitoring and indicating the fill level in the rainwater storage tank (Item 35). Lay the sensor connection line to the rainwater storage tank in a protective pipe. Lay the cable loosely. Avoid kinks and nodes. To prevent the sensor from being soiled by dirt, attach the filling level sensor (Item 37) at least 100 mm above the bottom of rainwater storage tanks with "floating intake" (Item 33).
- Alternatively, a float switch (Item 38) can be installed in the rainwater storage tank and connected to the control device to stop the pumps (Item 36) from running dry.
- Connect the on-site feeding pump (Item 36) in the rainwater storage tank to the control device.

7 Commissioning



DANGER

Danger of death due to electrical current!

Improper conduct when carrying out electrical work can lead to death due to electric shock!

- Only have electrical connection established by an electrician approved by the local energy supply company.
- Observe applicable local regulations.
- Before swapping the phases, switch off the main switch of the system and secure it against unauthorised restarting.



DANGER

Danger of death as supply pressure is too high!

Excessive supply pressure (nitrogen) in the diaphragm expansion tank can lead to damage or destruction of the tank and thus to personal injury.

- Observe the safety measures for handling pressurised vessels and technical gases.
- The pressures in these installation and operating instructions (Fig. 3b and 4) are given in **bar**. If other units of pressure measurement are used, convert the figures correctly.



WARNING

Risk of injury from a lack of protective equipment!

Danger of (serious) injuries during work.

- Wear safety shoes.

CAUTION

Risk of damage to property!

Dry running can lead to the pumps developing leakages and to motor overload.

- Ensure that the pumps do not run dry to protect the mechanical seal and the plain bearings.



NOTICE

We recommend that the initial commissioning of the system is performed by the Wilo customer service department.

- Contact your dealer, your nearest Wilo representative or the Wilo customer service department.



NOTICE

Automatic activation after power cut

Depending on the process, the product is activated and deactivated using separate controls. The product may automatically be activated following power cuts.

7.1 Preparations and control measures

- Check that all on-site wiring has been performed correctly, in particular the earthing, prior to initial activation.
- Check that the pipe adaptors are not under stress.
- Fill the hybrid tank a little via the solenoid valve (manual mode, see control device user manual).

- Fill the hybrid tank via the feed line from the rainwater storage tank (manual mode, see control device user manual).



NOTICE

- Detailed instructions are provided in the enclosed installation and operating instructions for the control device.

- Fill and vent the inlet side and pumps.
 - Open the shut-off valves on the inlet side (Fig. 2b, Item 9) and close the shut-off valves on the discharge side (Fig. 2a, Item 12).
 - Loosen the filling/venting screw (Fig. 2b, Item 26) of each pump one after another so that the air can escape completely.
 - If necessary, fill via the opening of the venting screw (use a funnel).
 - Close the venting screws once the pumps have been fully vented.



NOTICE

- Detailed instructions for the pump can be found in the enclosed installation and operating instructions for the pump.

- Fill and vent the discharge side.
 - Open the shut-off valves on the discharge side (Fig. 2b, Item 12).
 - Loosen the venting screw (Fig. 3a, Item 18) of the pressure transmitter unit so that the air can escape completely.
 - Retighten the venting screw.
 - If necessary, top up the hybrid tank to restore the water level.
- Check the connections of the water-bearing parts for impermeability.
- Check and set the required operating parameters on the control device in accordance with the attached installation and operating instructions.
- Open the valve on the consumer side and fill the system completely in fresh water mode.
- Check the diaphragm expansion tank (Fig. 3b, Item 7) for correctly set supply pressure (Fig. 3b and 4). To do so:
 1. Depressurise the diaphragm expansion tank on the water side:
 - ⇒ Close the flow-through fixture (Fig. 3, Item A).
 - ⇒ Allow the residual water to escape via the drain (Fig. 3, Item B).
 2. Remove the dust cap.
 3. Check the gas pressure at the air valve of the diaphragm expansion tank with an air pressure gauge (Fig. 3b, Item C):
 - ⇒ If the pressure is too low (PN 2 = pump switch-on pressure p_{\min} minus 0.2 – 0.5 bar or value given in the table on the tank (Fig. 4)), correct by filling with nitrogen by the Wilo customer service.
 - ⇒ If the pressure is too high: Release nitrogen from the valve until the required value is reached.
 4. Reinstall the dust cap.
 5. Close the drain valve on the flow-through fixture.
 6. Open the flow-through fixture.



NOTICE

Observe the respective installation and operating instructions for the individual component.

7.2 Commissioning the system



WARNING

Risk of damage to your health!

Risk of damage to your health due to contaminated drinking water.

- Ensure that pipe and system flushing has been carried out.
- If the system is not used for a longer period of time, replace the water.

Once all preparations and control measures have been carried out according to “General preparations and control measures” section:

1. Activate the main switch on the control device.
2. Set the control to automatic mode.
3. Open the shut-off valves at the pump and in the suction and discharge pipe.

The pressure control system switches on the pumps until the consumer piping is filled with water and the set pressure has built up. If the pressure no longer changes (no consumer requirement within a preset time), the control system switches off the pump.

- Refer to the installation and operating instructions for the pump and control device for a precise description.
- See also: Preparations and control measures page [► 29]

8 Shutdown/dismantling

In case of maintenance or repair of the rainwater utilisation system, take the system out of operation as follows:

1. Switch off the voltage supply and secure it against unauthorised reactivation.
2. Close the shut-off valve upstream and downstream of the system.
3. Shut off the fresh water.
4. Shut off the diaphragm expansion tank at the throughflow fitting and drain it.
5. If necessary, drain the pump(s)/system completely by opening the lower drainage screws on the pump.

9 Maintenance

9.1 Tests of the rainwater utilisation system

To guarantee maximum operational reliability at the lowest possible operating costs, we recommend that the rainwater utilisation system is checked and maintained regularly (see DIN 1988 standard). It is advisable to enter into a maintenance contract with a specialist company or with the Wilo customer service department.

The following checks must be carried out on a regular basis:

- Checking that the rainwater utilisation system is ready for operation.
- Inspection of the mechanical seals on the pumps. The mechanical seal needs water for lubrication. Water may leak out of the gasket slightly. In case of a larger water leak, replace the mechanical seal.
- Check the diaphragm expansion tank (every six months) for correctly set supply pressure and impermeability (Fig. 3b and 4).
- Check the filling level sensor of the level control device in the hybrid tank for dirt (annually).

9.2 Checking the supply pressure

CAUTION

Risk of property damage due to incorrect supply pressure!

Incorrect supply pressure influences the functionality of the diaphragm expansion tank and can lead to increased wear of the diaphragm and to system malfunctions. Excessive supply pressure will damage the diaphragm expansion tank.

- Check supply pressure.

- Depressurise the diaphragm expansion tank on the water side (close the flow-through fixture (Fig. 3b – Item A). Allow the residual water to escape via the drain (Fig. 3b – Item B).

- Check the gas pressure at the diaphragm expansion tank valve (top, remove dust cap) with an air pressure gauge (Fig. 3b – Item C).
- If necessary, correct the pressure by filling with nitrogen. (PN 2 = pump switch-on pressure p_{\min} minus 0.2 – 0.5 bar or value given in the table on the tank (Fig. 4) – Wilo customer service). If the pressure is too high, release nitrogen from the valve.
- Put the dust cap back on.
- Close the drain valve on the flow-through fixture.
- Open the flow-through fixture.



NOTICE

- Observe the respective manufacturer's documentation for the component.

10 Faults, causes and remedies



NOTICE

- Have faults, particularly those affecting the pumps or the control unit, remedied exclusively by the Wilo customer service or a specialist company.



NOTICE

- The general safety instructions must be observed during any maintenance or repair work.
- The installation and operating instructions of the pumps and the control device must be observed.

The faults specified here are general faults.

- If errors are shown on the display of the control device, observe the installation and operating instructions for the control device.

Fault	Cause	Remedy
Display on the control device incorrect		Observe the installation and operating instructions for the control device.
Pump does not start	No mains voltage	Check the fuses, cables and connections.
	Main switch "OFF"	Switch on the main switch.
	Shut-off device closed at pressure sensor/ pressure switch	Check and if necessary, open shut-off valve.
	Start-up pressure is set too low	Check the setting, correct if necessary.
	Fuse defective	Check the fuse protection and replace it if necessary.
Pump generates no or insufficient power	Fault indication on control device	Observe the installation and operating instructions for the control device.
	Control device not in automatic mode	Observe the installation and operating instructions for the control device.
	Motor protection has triggered	Check the default values against the pump and motor data, measure the current values and correct the setting if necessary. Check the motor for defects, and replace if necessary.
	Power contactor defective	Check and replace it if necessary.
	Turn-to-turn fault in the motor	Check, if necessary, replace motor or have it repaired.
Air has entered the system	Air has entered the system	Check and, if necessary, seal the piping and vent the pumps.
	No switchover to fresh water operation	Check the water level in the hybrid tank using the fill level indicator on the control device; check the parameters on the control device; if necessary, affix the filling level sensor correctly.

Fault	Cause	Remedy
	Air has entered the inlet via hybrid tank in fresh water mode	Fresh water level in hybrid tank too low; check solenoid valve and inlet pressure; check parameters on control device.
	Impellers clogged	Check pump and replace or have it repaired if necessary.
Pump does not shut down	Switch-off pressure is set too high	Check the setting, correct if necessary.
	Switch-off pressure not reached	Compare the pressure display on the control device with the pressure gauge display, determine other causes.
	Non-return valve leaking	Check and replace the seal or non-return valve if necessary.
Switching frequency too high or fluttering	Supply pressure on diaphragm expansion tank incorrect	Check the supply pressure, correct if necessary.
	Inlet pipe clogged or shut off	Check the inlet pipe and, if necessary, remove the clogging or open the shut-off valve.
	Shut-off valve at diaphragm expansion tank closed	Check shut-off valve, open if necessary.
	Switching difference set too low	Check the setting, correct if necessary.
	Air in the pump	Vent pump.
Pump is not stable and/or making unusual noises	Air in the pump	Vent pump.
	Inlet pipe clogged or closed	Check the inlet pipe and, if necessary, remove the clogging or open the shut-off valve.
	Air in the inlet	Check and, if necessary, seal the piping and vent the pump.
	Impellers clogged	Check pump and replace or have it repaired if necessary.
	Volume flow too high	Check the pump data and default values, correct if necessary.
	Bearing damage	Check the pump/motor and replace it or have it repaired if necessary.
Current consumption too high	Non-return valve leaking	Check and replace the seal or non-return valve if necessary.
	Volume flow too high	Check the pump data and default values, correct if necessary.
Water sprays out of the funnel of the hybrid tank's drinking water replenishment system	Jet regulator at the valve outlet slightly blocked	Clean the jet regulator.
	Water pressure too high	Actuate (throttle) or retrofit a throttle valve in the drinking water pipe.
Drinking water replenishment active despite full rainwater storage tank	Hybrid tank filling level sensor dirty or defective	Clean or replace the level sensor.
	Parameters on the control device set incorrectly	Check, correct if necessary.
Water leaking out of the hybrid tank overflow connection	Hybrid tank filling level sensor dirty or defective	Clean or replace the level sensor.
	Parameters on the control device set incorrectly	Check, correct if necessary.
	Filling level sensor of the hybrid tank not affixed correctly	Check fit in the retaining tube; correct if necessary. Slightly tighten the screwed connection to fix the cable.

Fault	Cause	Remedy
Water from the rainwater storage tank feed line leaking via the overflow connection of the hybrid tank	Lifting effect is occurring	Check pipework routing and retrofit a vacuum relief valve in the ascending pipe of the feed pipe if necessary.
	Water keeps running for a short time	Reduce the switching threshold for switching off the pump or install an electrically operated control valve upstream of the port for the feed line.

You can find information on faults to the pump or the control device not dealt with here in the attached installation and operating instructions for the components concerned.

- If a fault cannot be repaired, contact an installer or Wilo factory customer service.

11 Spare parts

Spare parts are ordered via customer service. To avoid return queries and incorrect orders, the serial or article number must always be supplied. **Subject to change without prior notice!**

12 Disposal

12.1 Information on the collection of used electrical and electronic products

Proper disposal and appropriate recycling of this product prevents damage to the environment and danger to your personal health.



NOTICE

Disposal in domestic waste is prohibited!

In the European Union this symbol may be included on the product, the packaging or the accompanying documentation. It means that the electrical and electronic products in question must not be disposed of along with domestic waste.

To ensure proper handling, recycling and disposal of the used products in question, please note the following points:

- Hand over these products at designated, certified collection points only.
- Observe the locally applicable regulations!

Please consult your local municipality, the nearest waste disposal site, or the dealer who sold the product to you for information on proper disposal. See www.wilo-recycling.com for more information about recycling.

12.2 Batteries/rechargeable batteries

Batteries and rechargeable batteries must not be disposed of with domestic waste and they must be removed before product disposal. End consumers are legally obliged to return all used batteries and rechargeable batteries. For this purpose, you can return used batteries and rechargeable batteries free of charge at municipal collection points or specialist retailers.



NOTICE

Disposal in domestic waste is prohibited!

Batteries and rechargeable batteries affected are marked with this symbol. The identifier for the heavy metal they contain is displayed beneath the graphic:

- **Hg** (mercury)
- **Pb** (lead)
- **Cd** (cadmium)

13 Appendix

13.1 Captions

Fig. 1a Dimensions with Medana 405 pump

Fig. 1b Dimensions with Medana 605 pump

Fig. 2a Example view of AF400

Fig. 2b Example side view of AF400 detail

1	Pump
2	Control device
3	Base frame
4	Hybrid tank
5	Solenoid valve / fresh water inlet connection from water mains
7	Diaphragm expansion tank
8	Connection inlet from rainwater storage tank
9	Shut-off valve on the inlet side...
10	Screwed connection with non-return valve on the inlet side
12	Shut-off valve on the discharge side
13	Discharge pipe
14	Pressure sensor (on the discharge side)
15	Pressure gauge (on the discharge side)
17	Overflow connection to the sewer system for HT100
20	Vibration absorber
21	Funnel (type AA air gap with unrestricted discharge)
22	Inspection opening/cover
23	Filling level sensor of the hybrid tank
24	Motor
25	Draining at pump
26	Venting at pump
27	Upper connection for expansion tank (Ø 110 mm)
28	Lower connection for expansion tank (Ø 160 mm)
29	Earthing connection

Fig. 3a Example pressure sensor (on the discharge side) and diaphragm expansion tank kit

Fig. 3b Operation of throughflow fitting / pressure test diaphragm expansion tank

7	Diaphragm expansion tank
14-a	Pressure sensor
14-b	Electrical connection, pressure sensor
15	Pressure gauge (on the discharge side)
16	Flow-through fixture / throughflow fitting
18	Drain/venting
19	Shut-off valve
A	Open / Close
B	Drain
C	Check the supply pressure (nitrogen - N ₂)

Fig. 4 Information table nitrogen pressure diaphragm expansion tank (example)

a	Nitrogen pressure according to the table
b	Start-up pressure base-load pump PE (bar)
c	Nitrogen pressure PN 2 (bar)

Fig. 4 Information table nitrogen pressure diaphragm expansion tank (example)

d	Notice: Nitrogen measurement without water
e	Notice: Caution! Fill with nitrogen only.

Fig. 5 System diagram



	Suction line from the rainwater storage tank
	Discharge pipe
	Top-up connection
33	Floating intake with filter and non-return valve on the feeding pump
35	Rainwater storage tank
36	Feeding pump in the rainwater storage tank
37	Filling level sensor of rainwater storage tank
38	Float switch

Fig. 6a Hybrid tank and filling level sensor

23	Filling level sensor of the hybrid tank
25	Draining at pump
a	Maximum usable water level
b	Minimum usable water level

Fig. 6b Fresh water replenishment characteristic curve

p	Relative pressure in the water mains at the extraction point in bar
Q	Flow rate in m ³ /h







wilo



Local contact at
www.wilo.com/contact

Pioneering for You

WILO SE
Wilopark 1
44263 Dortmund
Germany
T +49 (0)231 4102-0
T +49 (0)231 4102-7363
wilo@wilo.com
www.wilo.com