

Wilo-Rexa MINI3-S



en Installation and operating instructions



Rexa MINI3-S
<http://qr.wilo.com/413>

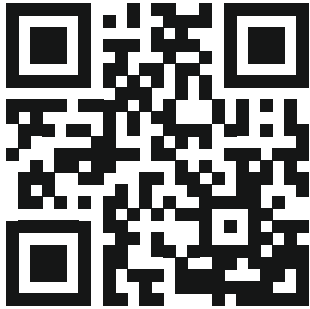

Rexa MINI3
<https://qr.wilo.com/405>

Table of contents

1 Safety	4	13.1 Information on the collection of used electrical and electronic products.....	13
1.1 About these instructions	4	13.2 Oil.....	13
1.2 Identification of safety instructions	4		
1.3 Personnel qualifications.....	4		
1.4 Pump with macerator.....	4		
1.5 Fluids hazardous to health	5		
1.6 Personal protective equipment	5		
1.7 Transport and storage.....	5		
1.8 Installation	5		
1.9 Electrical connection.....	5		
1.10 During operation.....	5		
1.11 Removal.....	5		
1.12 Clean and disinfect	6		
1.13 Maintenance tasks.....	6		
1.14 Operating fluid	6		
1.15 Copyright	6		
2 Product description and function	6		
2.1 Description.....	6		
2.2 Technical data	7		
2.3 Type key.....	7		
2.4 Scope of delivery.....	7		
2.5 Functions	7		
3 Application/use	7		
3.1 Intended use.....	7		
3.2 Improper use.....	7		
4 Transport and storage	8		
5 Installation and electrical connection	8		
5.1 Installation types	8		
5.2 Installation	8		
5.3 Electrical connection.....	9		
6 Commissioning	10		
6.1 Before activating.....	11		
6.2 Switching on and off	11		
6.3 Test run	11		
6.4 During operation.....	11		
7 Shut-down	11		
8 Removal	11		
8.1 Stationary wet well installation	11		
8.2 Portable wet well installation.....	12		
9 Cleaning	12		
9.1 Clean pump.....	12		
10 Maintenance	12		
10.1 Operating fluid	12		
10.2 Oil change	12		
10.3 General overhaul.....	13		
11 Faults, causes and remedies	13		
12 Spare parts	13		
13 Disposal	13		

1 Safety

1.1 About these instructions

These instructions form part of the product. Compliance with the instructions is essential for correct handling and use:

- Read the instructions carefully before all activities.
- Keep the instructions in an accessible place at all times.
- Pass the instructions on to a subsequent owner.
- Observe all product specifications.
- Observe the markings on the product.

The language of the original operating instructions is German. All other languages for these instructions are translations of the original operating instructions.

Failure to observe the instructions will result in danger to persons or damage to property. The manufacturer is not liable for damage caused by:

- Improper use.
- Incorrect operation.

1.2 Identification of safety instructions

In these installation and operating instructions, safety instructions are displayed as follows:

- Danger to persons: Safety instructions are **preceded by a corresponding symbol** and are shaded in grey.
- Damage to property: Safety instructions start with a signal word and are displayed **without** a symbol.

Signal words

- **DANGER!**
Failure to follow the instructions will result in serious injuries or death!
- **WARNING!**
Failure to follow the instructions can lead to (serious) injury!
- **CAUTION!**
Failure to follow the instructions can lead to potentially irreparable property damage.
- **NOTICE!**
Useful information on handling the product

Symbols

These instructions use the following symbols:



Danger caused by electric voltage



Danger of explosion



Warning of hand injuries (being crushed, cut)



General warning symbol



Personal protective equipment: wear protective gloves



Personal protective equipment: wear face mask



Personal protective equipment: wear safety glasses



Useful information

1.3 Personnel qualifications

- Persons aged 16 and over
- Have read and understood the installation and operating instructions

Children and persons with limited abilities in the household

This device can be used by children from 8 years of age as well as people with reduced physical, sensory or mental capacities or lack of experience and knowledge if they are supervised or instructed on the safe use of the device and they understand the dangers that can occur. Children are not allowed to play with the device. Cleaning and user maintenance must not be carried out by children without supervision.

1.4 Pump with macerator

The pump is equipped with a macerator on the suction port. The macerator has rotating and fixed blades. The blades are accessible from the outside.



WARNING

Risk of injury on the macerator!

The blades are extremely sharp. There is a danger of cuts and similar injuries!

- Never touch the macerator!
- Always carry the product by the handle!
- Always wear protective gloves (uvex phynomic wet) when using the product!

1.5 Fluids hazardous to health

In stagnant water (e.g. pump sump, soakaway, etc.) germs which are hazardous to health can form. There is a danger of bacterial infections!

- Clean and disinfect the product thoroughly after removal!
- Inform all persons about the pumped fluid and the danger it poses!

1.6 Personal protective equipment

The aforementioned branded products constitute non-binding suggestions. Similar products from other brands can also be used. WILO SE does not assume any liability for the aforementioned products.

Protective equipment: Transport, installation, removal and maintenance

- Safety shoes: uvex 1 sport S1
- Protective gloves (EN 388): uvex phynomic wet

Protective equipment: Cleaning work

- Protective gloves (EN ISO 374-1): uvex pro-fapren CF33
- Safety goggles (EN 166): uvex skyguard NT
- Breathing protection mask (EN 149): Half mask 3M series 6000 with filter 6055 A2

1.7 Transport and storage

- Wear protective equipment!
- Always carry the product by the handle!
- Clean product and disinfect if necessary!
 - Dirt fosters the formation of germs.
 - Encrustations may lead to the impeller becoming blocked.

1.8 Installation

- Wear protective equipment!
- Do not install damaged or defective products.

- If there is a risk of germ formation, observe the following points:
 - Ensure sufficient air exchange.
 - Wear a breathing protection mask e.g. Half mask 3M series 6000 with filter 6055 A2

1.9 Electrical connection

- Do not connect products with a damaged connection cable! Have the connection cable replaced by a qualified electrician or the customer service.
- Mains connection with correctly installed protective earth conductor.
- Install the residual-current device (RCD) with 30 mA.
- Fuse protection at mains connection: max. 16 A.
- **Product without plug:** Electrical connection must be carried out by a qualified electrician!

1.10 During operation

- The pumping of highly inflammable and explosive fluids (petrol, paraffin, etc.) in their pure form is strictly prohibited!
- If persons come into contact with the pumped fluid (accessible basins*), do not commission the product.

*Definition of “accessible basins”

Installation sites that can be walked on and directly accessed without tools (examples below):

- Garden ponds
- Swimming ponds
- Cesspools

NOTICE! The specifications applicable to swimming pools also apply to accessible basins.

1.11 Removal

- Wear protective equipment!
- **Product without plug:** Have the connection cable disconnected from the mains by a qualified electrician.
- Depending on the operating mode and duration, the housing parts become hotter than 40 °C (104 °F).
 - Only touch the product by the carrying handle.

- Allow product to cool down.
- Clean the device thoroughly.
- If there is a risk of germ formation, observe the following points:
 - Ensure sufficient air exchange.
 - Wear a breathing protection mask e.g. Half mask 3M series 6000 with filter 6055 A2
 - Disinfect product.

1.12 Clean and disinfect

- Wear protective equipment!
The protective equipment prevents contact with germs that are hazardous to health and the disinfectant.
- If a disinfectant is used, follow the manufacturer's instructions!
 - Wear protective equipment according to the manufacturer's instructions! If in doubt, ask your specialist dealer.
 - Inform all persons about the disinfectant and how to use it correctly!

1.13 Maintenance tasks

- Wear protective equipment!
- Carry out maintenance work in a clean, dry and well-lit place.
- Only original parts of the manufacturer may be used. The use of any non-original parts releases the manufacturer from any liability.
- Collect any leakage of fluid and operating fluid immediately.

1.14 Operating fluid

The oil is located in the sealing chamber. It serves to lubricate the seal on the motor and pump side.

- Absorb leakages immediately.
- If major leakages occur, contact customer service.
- If the seal is defective, the oil enters the pumped fluid and the sewer.
- Collect waste oil by type (unmixed) and dispose of it in accordance with regulations at a certified collection point.
- **Skin contact:** Rinse skin areas thoroughly with soap and water. If skin irritation occurs, consult a doctor.

- **Contact with eyes:** Remove the contact lenses. Rinse eye thoroughly with water. If eye irritation occurs, consult a doctor.
- **Ingestion:** Consult a doctor immediately! Do not induce vomiting!

1.15 Copyright

WILO SE © 2023

The reproduction, distribution and utilisation of this document in addition to communication of its contents to others without express consent is prohibited. Offenders will be held liable for payment of damages. All rights reserved.

2 Product description and function

2.1 Description

Fully submersible grinder pump for stationary and portable wet well installation in intermittent operation.



Fig. 1: Overview

1	Handle
2	Motor housing
3	Discharge connection
4	Pump housing with pump support foot
5	Connection cable

Rexa MINI3-S ... /M ... /P

Sewage pump with radial macerator with double shear effect. Horizontal discharge port with flange and oval connection. Hydraulics housing and impeller made of grey cast iron; macerator made of hardened cutting steel. Surface-cooled 1~ motor with self-switching thermal motor monitoring. Oil-filled sealing chamber with two mechanical seals. Stainless steel motor housing. Detachable connection cable with capacitor box and plug (CEE 7/7).

Rexa MINI3-S ... /M ... /A

Sewage pump with radial macerator with double shear effect. Horizontal discharge port with flange and oval connection. Hydraulics housing and impeller made of grey cast iron; macerator made of

hardened cutting steel. Surface-cooled 1~ motor with self-switching thermal motor monitoring. Oil-filled sealing chamber with two mechanical seals. Stainless steel motor housing. Detachable connection cable with capacitor box, float switch and plug (CEE 7/7).

Rexa MINI3-S ... /T ... /O

Sewage pump with radial macerator with double shear effect. Horizontal discharge port with flange and oval connection. Hydraulics housing and impeller made of grey cast iron; macerator made of hardened cutting steel. Surface-cooled 3~ motor with thermal motor monitoring. Oil-filled sealing chamber with two mechanical seals. Stainless steel motor housing. Detachable connection cable with bare cable ends.

2.2 Technical data

Date of manufacture	See rating plate ¹⁾
Mains connection	See rating plate
Rated power	See rating plate
Max. delivery head	See rating plate
Max. volume flow	See rating plate
Activation type	See rating plate
Speed	See rating plate
Discharge connection	DN 32/40
Operating mode, immersed	S1
Operating mode, non-immersed	S3 10% ²⁾
Fluid temperature	3 ... +40 °C (37 ... 104 °F)
Fluid temperature, short-term for 3 min	-
Max. immersion depth	7 m (23 ft)
Protection class	IP68
Insulation class	F
Max. switching frequency /h	60/h

Key

¹⁾ In accordance with ISO 8601

²⁾ 1 min operation, 9 min standby

2.3 Type key

Ex-ample:	Rexa MINI3-S03/M008-523/A
Rexa	Submersible sewage pump
MINI3	Series
S	Macerator
03	Nominal diameter of the discharge connection: DN 32/40
M	Mains connection version: <ul style="list-style-type: none"> • M = single-phase current (1~) • T = three-phase current (3~)
008	Value/10 = rated power P_2 in kW
-	Not Ex-rated
5	Mains frequency: 5 = 50 Hz/6 = 60 Hz
23	Rated voltage code

A Additional electrical equipment:

- O = with bare cable end
- P = with plug (CEE 7/7)
- A = with float switch and plug (CEE 7/7)

2.4 Scope of delivery

- Pump
- Installation and operating instructions

2.5 Functions

2.5.1 Self-switching thermal motor monitoring

If the motor becomes too hot, the pump is deactivated. After the motor has cooled down, the pump is automatically switched on again.

2.5.2 Float switch

The Rexa MINI3-S ... -A is equipped with a float switch. The float switch is used to switch the pump on and off depending on the level:

- Upper floater: Pump on
- Lower floater: Pump off

3 Application/use

3.1 Intended use

For the pumping in domestic areas of:

- Sewage containing faeces
- Wastewater (with small amounts of sand)

Sewage pumping according to 12050

The pumps meet the requirements of EN 12050-1.

3.2 Improper use



DANGER

Explosion due to pumping of explosive fluids!

Pumping highly inflammable and explosive fluids (e.g. petrol, paraffin, etc.) in their pure form poses a risk of fatal injury due to explosion!

- The pumps are not designed for these fluids.
- The pumping of highly inflammable and explosive fluids is prohibited.

The submersible pumps must **not be used** for pumping:

- Untreated sewage
- Drinking water
- Fluids containing hard components (such as stones, wood, metal, etc.)
- Fluids containing high quantities of abrasive contents (e.g. sand, gravel).
- Viscous fluids (e.g. oil and grease)
- Seawater

Intended use also includes compliance with this manual. Any other use is regarded as non-compliant with intended use.

4 Transport and storage

CAUTION

Soaked packaging may tear!

The product may fall on the ground if unprotected and may be damaged. Lift wet packaging carefully and replace it immediately!

- Wear protective equipment!
- Carry the pump by the handle. Never carry or pull on the connection cable!
- Clean the pump and disinfect if necessary.
- Close the discharge connection.
- Protect the connection cable against kinking and damage.
- Use original packaging for transport and storage.
- Pack the pump when dry. Wet or humid pumps may soften the packaging.
- Storage conditions:
 - Maximum: -15 ... +60 °C (5 ... 140 °F), max. humidity: 90 %, non-condensing
 - Recommended: 5 ... 25 °C (41 ... 77 °F), relative humidity: 40 ... 50 %

5 Installation and electrical connection

5.1 Installation types

- Vertical stationary wet well installation
- Vertical portable wet well installation

5.2 Installation

- Wear protective equipment!
- Do not install a damaged or defective pump.
- Frost-free location.
- Lay the connection cable properly. During operation there must be no danger (stumbling, damage, etc.).
- Float switch must be able to move freely!

5.2.1 Stationary wet well installation

A suspension unit must be installed for the stationary wet well installation. The on-site discharge pipe is connected to the suspension unit. The pump is connected to the suspension unit via a coupling connection. Observe and adhere to the following points:

- The connected discharge pipe must be self-supporting. The discharge pipe must not be supported by the suspension unit.
- The discharge pipe must not be smaller than the pump's discharge connection.
- Install all specified valves in accordance with local requirements (gate valve, non-return valve).
- Lay the discharge pipe frost-proof.
- Air pockets in the pump and in the discharge pipe can lead to delivery problems.

Installing the ventilation systems:

- E.g. Air vent valve
- In the discharge pipe
- Before the non-return valve
- Install the discharge pipe as a "pipe loop" to avoid backflow from the main public sewer.
At its highest point, the bottom edge of the pipe loop must be above the locally determined backflow level!

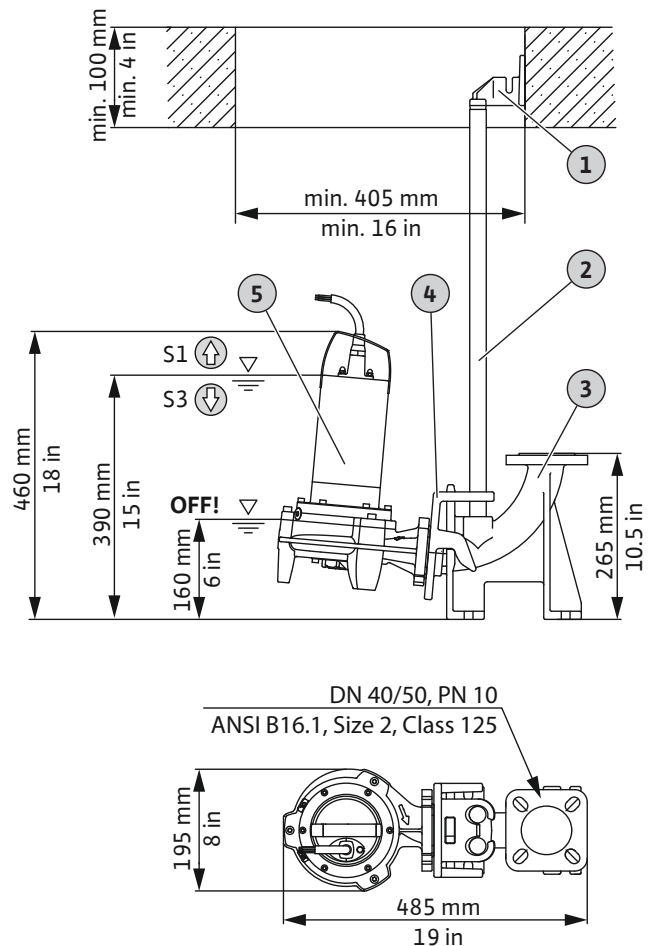

Fig. 2: Overview of components and installation dimensions

1	Upper holder for the guide pipe
2	Guide pipe 26.9x2 mm (1.06x0.08 in)
3	Foot elbow
4	Coupling connection
5	Pump
⬆	Fill level above: Continuous duty (operating mode immersed)
⬇	Fill level below: Intermittent periodic duty (operating mode non-immersed)
OFF	Switch-off level

The following accessories are required for installation:

- Suspension unit DN40/50 (article number: 2057179)
Consisting of foot elbow, coupling connection and upper holder.
 - Two guide pipes 26.9x2 mm (1.06x0.08 in), length: 6 m (19.7 ft) (article number: 6049244)
 - Stainless steel lifting chain, length: 6 m (19.7 ft) (article number: 6084893)
 - Installation sundries DN40/50/65 (article number: 6076963)
 - ✓ Suspension unit installed.
 - ✓ Pressure pipe properly installed.
 - ✓ Lifting chain installed on the carrying handle.
1. Attach the coupling connection to the discharge connection of the pump.
 2. Lift the pump. Thread the coupling connection onto the guide pipes.
 3. Drain the pump at the guide pipes up to the foot elbow.

4. Attach the lifting chain to the pump chamber opening.
5. Route the connection cable to the socket/power connection according to local regulations.
 - ▶ Pump is installed.

5.2.2 Portable wet well installation

The pump can be installed at any location on the application site when carrying out portable wet well installation. Observe and adhere to the following points:

- Secure the pump against falling over and moving (creeping) during use.
- Secure the pressure hose to the hose connection.

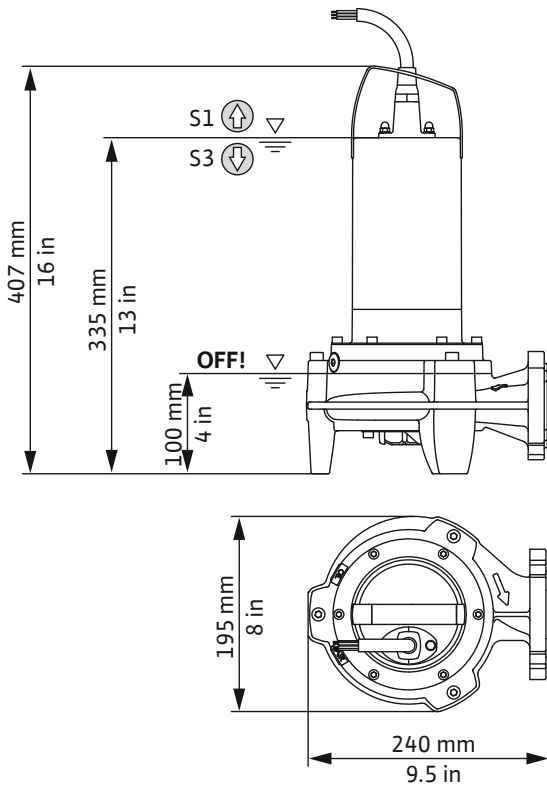

Fig. 3: Installation dimensions

↑	Fill level above: Continuous duty (operating mode immersed)
↓	Fill level below: Intermittent periodic duty (operating mode non-immersed)
OFF	Switch-off level

The following accessories are required for installation:

- Hose connection with 90° pipe elbow (article number: 2057179) Consisting of threaded flange, 90° pipe elbow and installation accessories
 - 5 m (16.4 ft) pressure hose, inside diameter: 42 mm (1.65 in), including hose clip (article number: 2027642)
 - ✓ Site is prepared
 - ✓ Hose connection assembled
1. Install the hose connection on the pressure port.
 2. Slide the hose clip over the pressure hose.
 3. Slide the pressure hose onto the hose connection.
 4. Secure the pressure hose to the hose connection using the hose clip.

5. Position the pump at the installation site.
 - CAUTION! Use a hard surface or underlay at the installation site to prevent sinking on soft substrate.**
6. Lay the pressure hose and fasten it in the appropriate place (e.g. drain). **CAUTION! If the pump is placed in a full chamber, hold the pump at a slight angle when immersing. This causes the air to escape from the pump!**
7. Route the connection cable to the socket/power supply.
 - ▶ Pump is installed.

5.3 Electrical connection

- Mains connection with correctly installed protective earth conductor.
- Residual-current device (RCD) is installed with 30 mA.
- Mains connection fuse protection: max. 16 A.
- Voltage (U) and frequency (f) data on the rating plate correspond to the data of the mains connection.

Do **not** connect the pump if:

- The connection cable is damaged
Have the connection cable replaced by a qualified electrician or the customer service.
- A standalone inverter is in use
Stand-alone inverters are used in autonomous power supplies, e.g. solar power supply, and can generate overvoltages. Overvoltages can destroy the pump.
- A multiple plug socket or power strip is in use
- An energy-saving plug is in use
This reduces the energy supply to the pump and the pump may heat up too much.
- Operation on start-up controls
The pump is not suitable for operation on a frequency converter or a soft start control.
- Explosive atmospheres
Do not connect and operate the pump inside potentially explosive atmospheres!

5.3.1 Connection: Pump with plug

The pump is equipped with a plug (CEE 7/7). The connection to the mains is established by inserting the plug into the socket (type E or type F). The plug is not watertight. **NOTICE! The thermal motor monitoring is self-switching. A separate connection is not necessary.**

Connection to an existing switchgear



DANGER

Risk of fatal injury due to electrical current!

Improper conduct when carrying out electrical work can lead to death due to electric shock!

- Electrical work must be carried out by a qualified electrician!
- Observe local regulations!

To connect the pump to a switchgear, cut off the plug. Connect the connection cable according to the connection diagram in the switchgear.

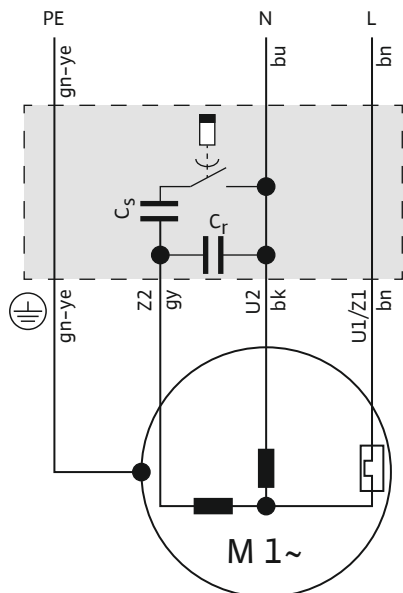

Fig. 4: Connection diagram 1~ motor

Wire colour	Terminal
Brown (bn)	L
Blue (bu)	N
Green/yellow (gn-ye)	Earth

5.3.2 Connection: Pump without a plug



DANGER

Risk of fatal injury due to electrical current!

Improper conduct when carrying out electrical work can lead to death due to electric shock!

- Electrical work must be carried out by a qualified electrician!
- Observe local regulations!

CAUTION

Irreparable damage as a result of water penetration

Connection cables without plugs feature bare cable ends. Water may penetrate the connection cable and pump via these bare cable ends. This will destroy both the connection cable and the pump. Never immerse the bare end of the connection cable in fluid. Firmly seal it during storage.

The pump has a connection cable with bare cable end. Connect the pump firmly to a switchgear. Observe the following points:

- Connection in the switchgear according to the connection diagram.
- Mains connection with clockwise rotating field
- Earth the device properly!

- Provide a motor protection switch!
The minimum requirement is a thermal relay/motor protection switch with temperature compensation, differential trip and re-activation lock according to local regulations.
Set the motor protection switch to the rated current (see rating plate).
- Install the mains disconnection device!
Minimum requirement: Main switch with all-pole disconnection.
- Thermal motor monitoring:
 - Sensor: Bimetallic strip
 - Number of temperature circuits: 1, temperature limiter
 - Connection values: max. 250 V(AC), 2.5 A, cos phi = 1
 - Threshold value: is set by the sensor.
 - Triggering status: When the threshold value is reached, switch off the pump!

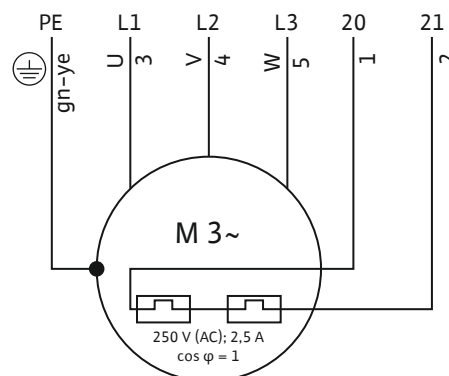

Fig. 5: Connection diagram 3~ motor

Wire number	Name	Terminal
1	20	WSK
2	21	WSK
3	U	L1
4	V	L2
5	W	L3
Green/yellow (gn-ye)	Earth	PE

6 Commissioning



DANGER

Risk of fatal injury due to electrical currents in accessible basins!

Do not operate the pump if there are persons in contact with the fluid. In the event of a fault this may cause death by electric shock! Only activate the pump when there are no longer any persons in contact with the fluid.



NOTICE

Check the inlet quantity!

The maximum inlet volume flow must be less than the maximum pump delivery rate. If the inlet quantity is higher, the pump will not be able to pump away the volume flow. The pump chamber may overflow!

6.1 Before activating

Check the following prior to activation:

- Has the electrical connection been carried out in accordance with regulations?
- Has the connection cable been routed safely?
- Can the float switch move freely?
- Temperature of the pumped fluid observed?
- Immersion depth observed?
- Are the pressure pipe and pump sump free of deposits?
- All gate valves in the pressure pipe open?

6.2 Switching on and off

Pump with plug, without float switch

1. Insert plug into socket.
 - ▶ Pump switches on.
1. Pull the plug out of the socket.
 - ▶ Pump switches off.

Pump with plug and float switch

1. Insert plug into socket.
 - ▶ Pump ready for operation. The pump switches on and off automatically depending on the fill level.

Pump with bare cable end (without plug)

Switch the pump on and off via a separate control. Read the installation and operating instructions for the control unit for further details.

6.3 Test run

If the pump is installed stationary (e.g. cesspool, overflow shaft), carry out a test run. Check the following points with the test run:

- General conditions (inflow quantity, switching points)
- Direction of rotation (with 3~ motors)

The test run must include three pump cycles.

1. Flood the pump chamber: Open inlet.
NOTICE! The required feed quantity for the test run can also be simulated using another water source.
2. When the switch-on level is reached: pump starts.
3. Switch-off level reached: pump stops.
4. Repeat two more pumping processes.
 - ▶ Once three pumping processes have been completed without problems, the test run is finished.

NOTICE! If the pump does not switch on once a week, repeat the test run every month.

6.4 During operation

CAUTION

Do not allow the pump to dry run!

Do not run the pump without fluid (dry run). Switch off the pump once the residual water level has been reached. Dry running may destroy the seal and cause the pump to be irreparably damaged.

Check the following points:

- Inlet quantity corresponds to the pump delivery rate.
- Float switch is operating correctly.

- Connection cable is not damaged.
- Pump free from deposits and encrustations.

7 Shut-down

During decommissioning, the pump is disconnected from the mains, but should remain installed. This ensures that the pump is always ready for operation.

- ✓ Completely immerse the pump in the fluid to protect the pump from frost and ice.
- ✓ Min. fluid temperature: +3 °C (+37 °F)
- ✓ Min. ambient temperature: +3 °C (+37 °F)

1. Disconnect the pump from the mains:
 - Pull plug.
 - Switch off the main switch on the switchgear.
2. Shut off the inlet.
 - ▶ Pump is out of operation.

If the pump remains installed after decommissioning, observe the following points:

- Ensure that the decommissioning requirements are maintained for the complete decommissioning period. Remove the pump if meeting these requirements cannot be guaranteed!
- If the pump will not be used for a prolonged period, switch on the pump and carry out one pumping process every two months to prevent encrustations and clogging. **CAUTION! Only carry out the pumping process under suitable operating conditions. Allowing the pump to dry run is strictly forbidden! Failure to observe these instructions will lead to irreparable damage to the pump!**

8 Removal



DANGER

Risk of infection due to fluids hazardous to health!



Hazardous germs can form in standing waters. If there is a risk of germ formation, observe the following points:



- Ensure sufficient air exchange.
- Wear a breathing protection mask e.g. Half mask 3M series 6000 with filter 6055 A2.
- Disinfect product.

- Wear protective equipment!
- Depending on the operating mode and duration, the housing parts become hotter than 40 °C (104 °F).
 - Only touch the product by the carrying handle.
 - Allow product to cool down.
- Clean the device thoroughly.

8.1 Stationary wet well installation

- ✓ Pump is decommissioned.
 - ✓ Inlet shut off.
1. Shut off the discharge pipe.
 2. Attach the lifting equipment to the handle.
 3. Slowly raise the pump and lift it over the guide pipes out of the operating space. **CAUTION! Do not damage the connec-**

tion cable! Hold the connection cables slightly taut when lifting!

4. Coil up the connection cables and attach them to the motor.
 - Do not kink.
 - Do not crush.
 - Observe the bending radii.
5. Thoroughly clean the pump (see section "Cleaning and disinfecting").

8.2 Portable wet well installation

✓ Pump has been decommissioned.

✓ Inlet shut off.

1. Coil up the connection cables and attach them to the motor.
 - Do not kink.
 - Do not crush.
 - Observe the bending radii.
2. Loosen the pressure hose from the pressure port.
3. Lift the pump out of the operating space. **CAUTION! Do not damage the connection cable! Pay attention to the connection cable when setting down the pump!**
4. Thoroughly clean the pump (see section "Cleaning and disinfecting").

9 Cleaning

- Wear protective equipment!
The protective equipment prevents contact with germs that are hazardous to health and the disinfectant.
- If a disinfectant is used, follow the manufacturer's instructions!
 - Wear protective equipment according to the manufacturer's instructions! If in doubt, ask your specialist dealer.
 - Inform all persons about the disinfectant and how to use it correctly!
- Drain the water used for cleaning into the sewage system.

9.1 Clean pump



WARNING

Risk of injury on the macerator!

The blades are extremely sharp. There is a danger of cuts and similar injuries!

- Never touch the macerator!
- Always carry the product by the handle!
- Always wear protective gloves (uvex phynomic wet) when using the product!

✓ Pump removed.

✓ Disinfectant is available.

1. Ensure that the plug or bare cable end is packed and stored in a watertight manner!
2. Rinse the pump and cable under clean, running water.
3. To clean the inside of the pump, guide the water jet inside through the pressure port.
4. Rinse attachments such as the pressure hose with clear running water.
5. Flush dirt residue on the floor into the sewage drain.
6. Allow the pump to dry out.

7. Clean plug or bare cable end with a damp cloth!

► Pump has been cleaned. Pack and store the pump.

10 Maintenance

- Wear protective equipment!
- Only perform the maintenance work described in these installation and operating instructions.
- Carry out maintenance work in a clean, dry and well-lit location.
- Use only original parts obtained from the manufacturer. The use of any non-original parts releases the manufacturer from any liability.
- Collect any leakage of fluid and operating fluid immediately.
- Dispose of the operating fluid at certified collection points.

10.1 Operating fluid

- Capacity: 220 ml (7.4 US.fl.oz)
- Interval for oil change: After 720 operating hours or 1x per year
- Oil types:
 - ExxonMobile: Marcol 52
 - ExxonMobile: Marcol 82
 - Total: Finavestan A 80 B (NSF-H1 certified)

10.2 Oil change

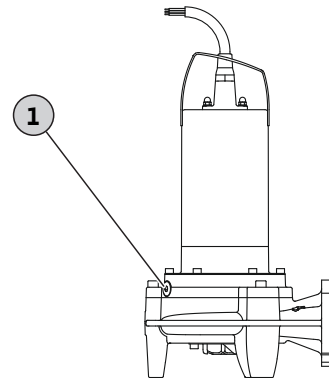

Fig. 6: Sealing chamber oil change

1	Sealing chamber screw plug
---	----------------------------

- ✓ Wear protective gloves!
 - ✓ Pump is removed, cleaned and if necessary disinfected.
 - ✓ Oil-resistant sealable collector tank is accessible.
1. Position the pump horizontally on a firm surface. The screw plug should face upwards.
 2. Secure the pump against falling over or slipping!
 3. Unscrew the screw plug slowly.
 4. Place a collector tank underneath the pump.
 5. Draining the oil: rotate the pump until the opening points downwards.
 6. Checking the oil: notify customer service if the oil contains metal swarf!
 7. Rotate the pump until the opening points upwards again.
 8. Filling the oil: pour the oil in through the opening.
 - ⇒ Comply with requirements concerning oil type and quantity!
 9. Clean the screw plug, replace the seal ring with a new one and fully screw it in.

10.3 General overhaul

Have the customer service team check the pump after 1,500 operating hours. All components will be checked for wear and damaged components will be replaced.

11 Faults, causes and remedies

Pump not starting or switches off after a short time

1. Interrupted power supply
 - ⇒ Check the electrical connection of the pump.
 - ⇒ Have a qualified electrician check fuses/residual-current devices.
2. Thermal motor monitoring has been tripped
 - ⇒ Allow the pump to cool down. The pump will start automatically.
 - ⇒ Pump switches on/off too frequently. Check the switching cycle of the float switch.
 - ⇒ Excessive fluid temperature. Check the temperature. If necessary, use a different pump.
3. Suction port/strainer/impeller silted/clogged
 - ⇒ Shut down the pump, remove it and clean it.
4. Float switch not operational
 - ⇒ The float switch must be able to move freely.

Pump starts up, but does not supply fluid

1. Pressure pipe/discharge pipe clogged
 - ⇒ Flush out the pressure pipe.
 - ⇒ Flush out the pressure hose.
 - ⇒ Remove any kinks in the pressure hose.
2. Swing check valve contaminated
 - ⇒ Shut down the pump, remove it and clean the discharge connection.
 - ⇒ Replace faulty swing check valve.
3. Water level too low
 - ⇒ Check inlet.
 - ⇒ Pump is pumping at a too low level. Check the switching cycle of the float switch.
4. Suction port/strainer silted/clogged
 - ⇒ Shut down the pump, remove it and clean it.
5. Air in the pump/pressure pipe
 - ⇒ Position the pump at a slight angle to allow air to escape.
 - ⇒ Install a bleed unit in the pressure pipe.

Delivery rate drops while the pump is running

1. Pressure pipe/discharge pipe clogged
 - ⇒ Flush out the pressure pipe.
 - ⇒ Flush out the pressure hose.
 - ⇒ Remove any kinks in the pressure hose.
2. Suction port/strainer silted/clogged
 - ⇒ Shut down the pump, remove it and clean it.
3. Air in the pump/pressure pipe
 - ⇒ Position the pump at a slight angle to allow air to escape.
 - ⇒ Install a bleed unit in the pressure pipe.
4. Signs of wear

⇒ Contact customer service.

Customer service

If the points listed here do not rectify the fault, contact customer service. Costs may be incurred when using customer service support! Please contact customer services for more information.

12 Spare parts

Spare parts are ordered via customer service. To avoid return queries and incorrect orders, the serial or article number must always be supplied. **Subject to change without prior notice!**

13 Disposal

13.1 Information on the collection of used electrical and electronic products

Proper disposal and appropriate recycling of this product prevents damage to the environment and danger to your personal health.



NOTICE

Disposal in domestic waste is prohibited!

In the European Union this symbol may be included on the product, the packaging or the accompanying documentation. It means that the electrical and electronic products in question must not be disposed of along with domestic waste.

To ensure proper handling, recycling and disposal of the used products in question, please note the following points:

- Hand over these products at designated, certified collection points only.
- Observe the locally applicable regulations!

Please consult your local municipality, the nearest waste disposal site, or the dealer who sold the product to you for information on proper disposal. See www.wilo-recycling.com for more information about recycling.

13.2 Oil



WARNING

Risk of environmental and health damage due to incorrect disposal of oils!

Oil is harmful to health and the environment! Do not dispose of oil with domestic waste or in the sewage system! Collect the oil in a sealable, oil-resistant container and dispose of it at a certified collection point.





wilo



Local contact at
www.wilo.com/contact

Pioneering for You

WILO SE
Wilopark 1
44263 Dortmund
Germany
T +49 (0)231 4102-0
T +49 (0)231 4102-7363
wilo@wilo.com
www.wilo.com