

Pioneering for You

wilo

Wilo-EMUport CORE



en Installation and operating instructions

Fig. 6: A

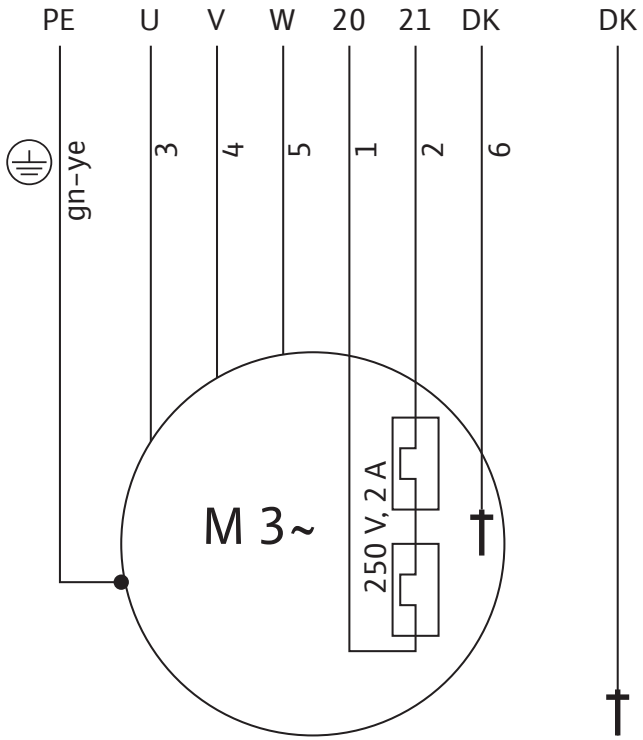

Fig. 6: B

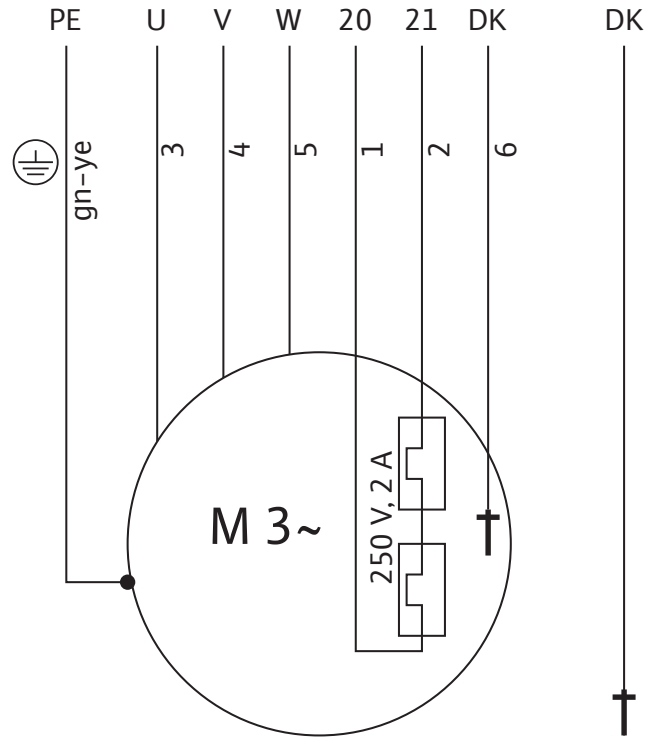

Fig. 6: C

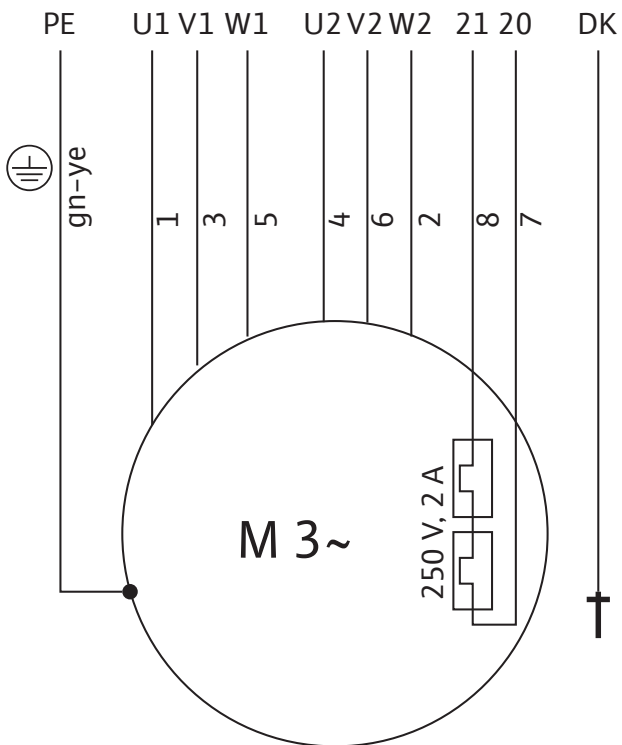

Fig. 6: D

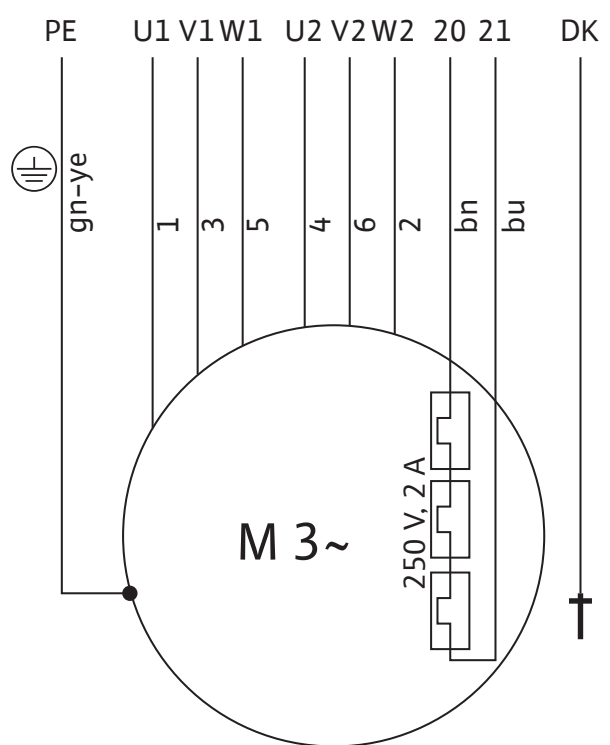

Fig. 6: E

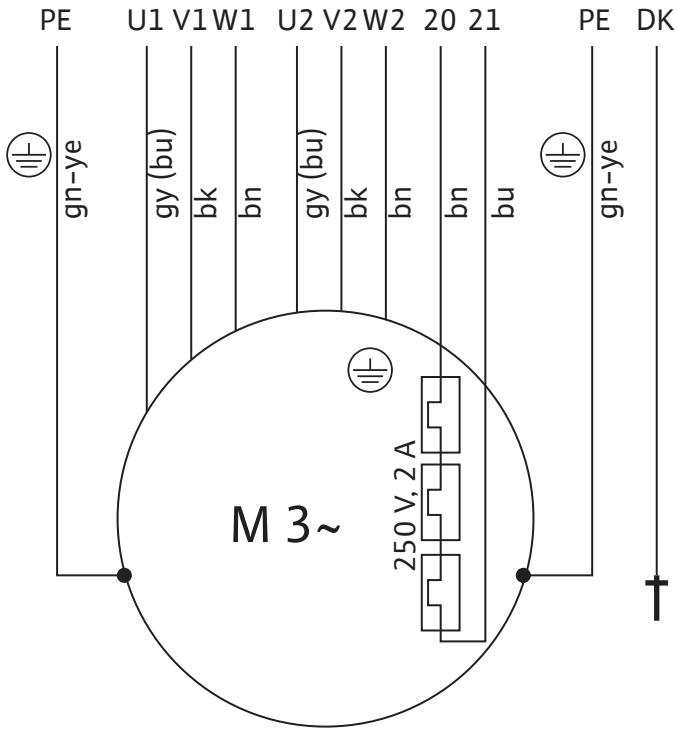

Fig. 6: F

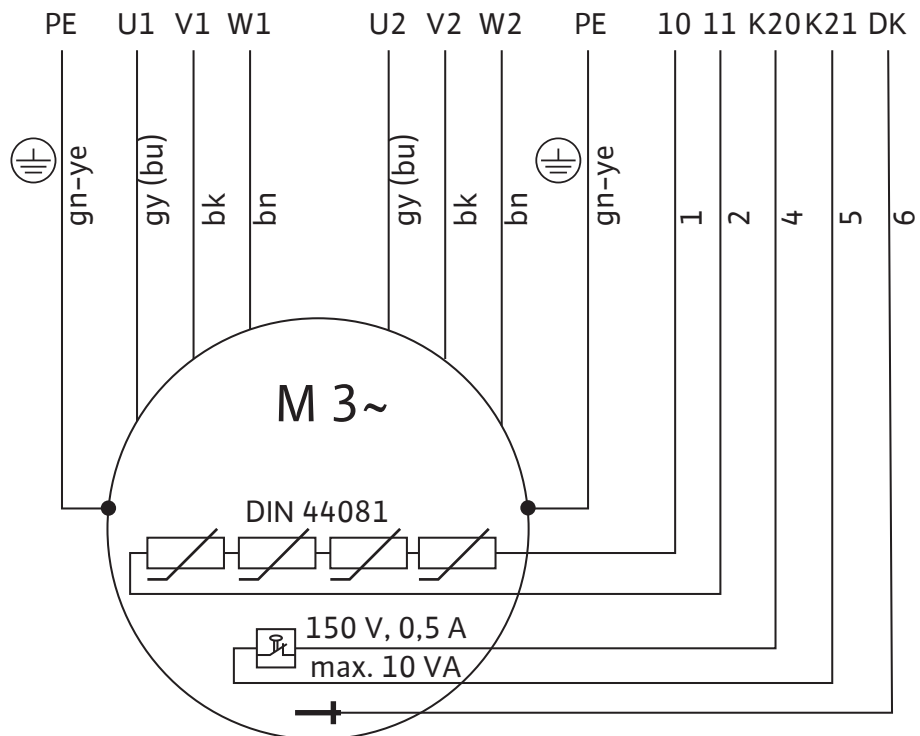

Fig. 12: P 13 motor

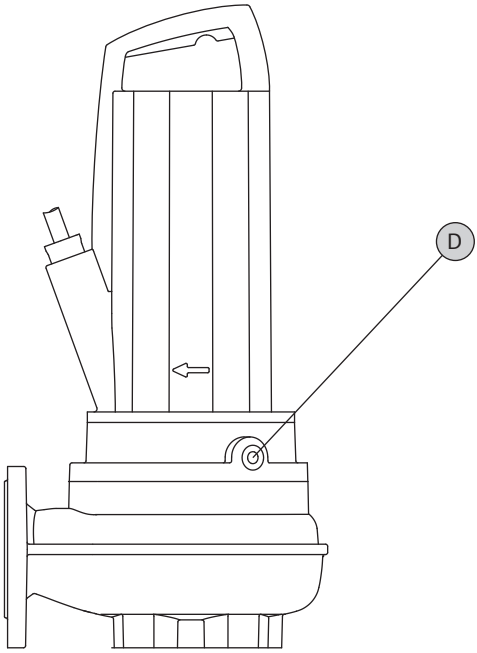

Fig. 13: FK 17.1 motor

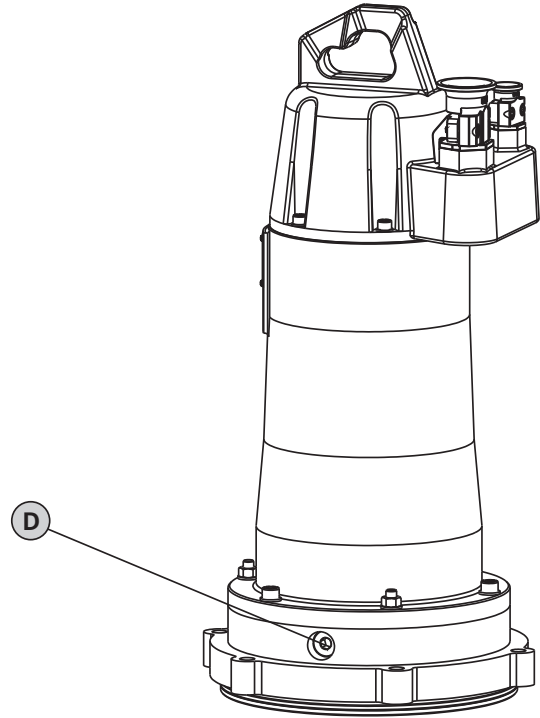
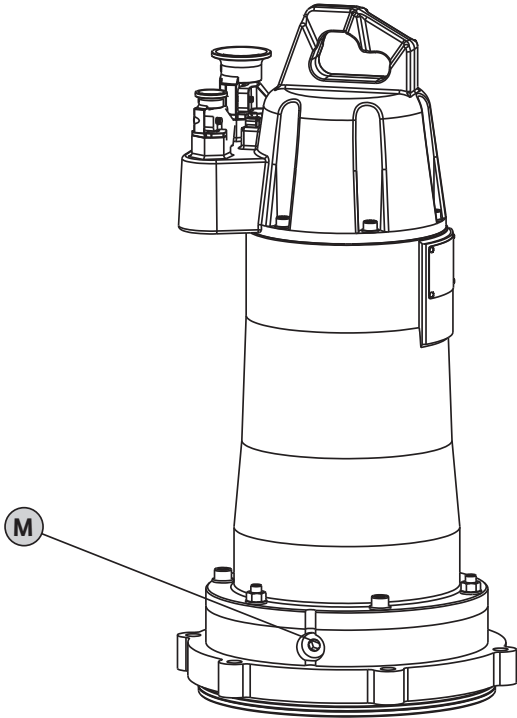

Fig. 14: FK 202 motor

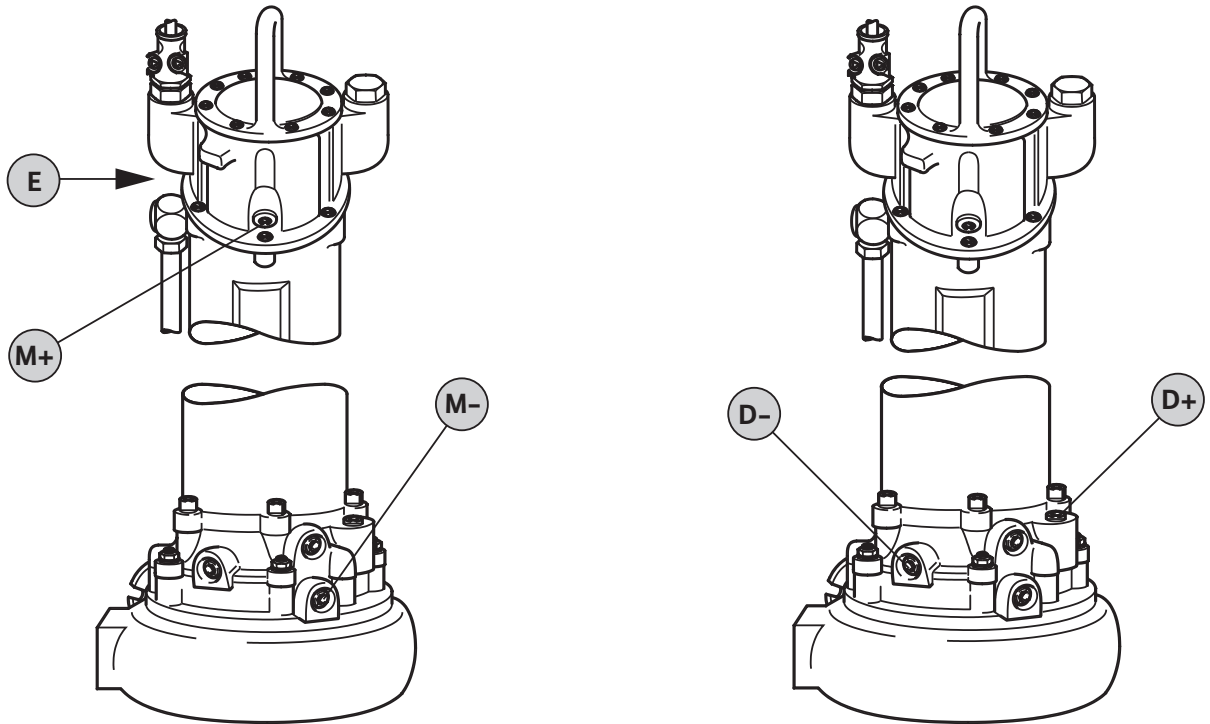
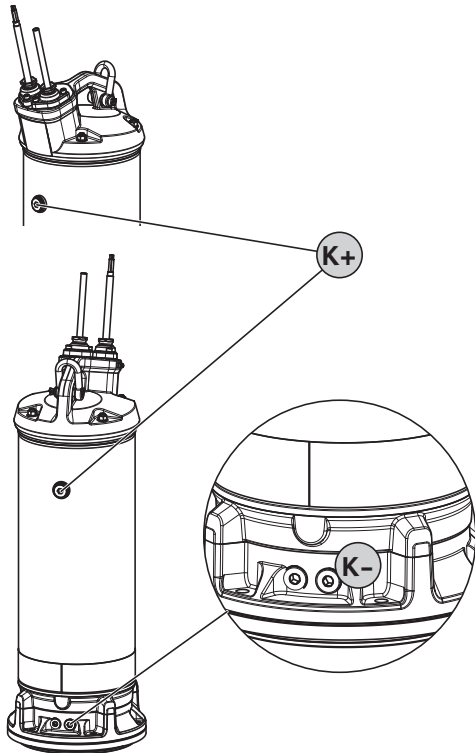

Fig. 15: FKT 20.2 motor



1.	Introduction	7	8.	Maintenance and repair	25
1.1.	About this document	7	8.1.	Basic tool equipment	26
1.2.	Personnel qualifications	7	8.2.	Operating fluid	26
1.3.	Copyright	7	8.3.	Logging	26
1.4.	Subject to change	7	8.4.	Maintenance intervals	26
1.5.	Warranty	7	8.5.	Maintenance work	27
2.	Safety	8	9.	Troubleshooting and possible solutions	30
2.1.	Instructions and safety instructions	8	9.1.	Overview of possible malfunctions	30
2.2.	General safety information	8	9.2.	Overview of possible causes and their remedies	30
2.3.	Electrical work	9	9.3.	Further steps for troubleshooting	31
2.4.	Safety and monitoring devices	9	9.4.	Spare parts	31
2.5.	Conduct during operation	9			
2.6.	Fluids	10			
2.7.	Sound pressure	10			
2.8.	Standards and guidelines used	10			
2.9.	CE marking	10			
3.	Product description	10			
3.1.	Intended use and fields of application	10			
3.2.	Structure	11			
3.3.	Operating principle	12			
3.4.	Ex protection	12			
3.5.	Operating modes	12			
3.6.	Technical data	13			
3.7.	Type key	13			
3.8.	Scope of delivery	13			
3.9.	Accessories (optionally available)	13			
4.	Transportation and storage	14			
4.1.	Delivery	14			
4.2.	Transportation	14			
4.3.	Storage	14			
4.4.	Return delivery	14			
5.	Installation	15			
5.1.	General	15			
5.2.	Installation types	15			
5.3.	Installation	15			
5.4.	Installation of separately delivered sewage pumps	19			
5.5.	Electrical connection	19			
5.6.	Minimum requirements for the switchgear	20			
6.	Commissioning/operation	21			
6.1.	Commissioning	21			
6.2.	Operation	22			
7.	Shutdown/disposal	24			
7.1.	Switching off the unit	24			
7.2.	Removal	24			
7.3.	Return delivery/storage	25			
7.4.	Disposal	25			

1. Introduction

1.1. About this document

The language of the original operating instructions is German. All other languages of these instructions are translations of the original operating instructions.

This manual is divided into individual sections, which are listed in the table of contents. Each section has a meaningful heading which clearly describes its content.

A copy of the EC-Declaration of conformity is an integral part of these installation and operating instructions.

If a technical modification is made to the designs named there without our agreement, this declaration loses its validity.

1.2. Personnel qualifications

All personnel who work on or with the lifting unit must be qualified for such work; electrical work, for example, may only be carried out by a qualified electrician. All personnel must be of legal age.

National accident prevention regulations must also be observed as a basis by the operating and maintenance personnel.

It must be ensured that personnel have read and understood the instructions in this operating and maintenance manual; if necessary, this manual must be ordered from the manufacturer in the required language.

This lifting unit is not intended for use by persons (including children) with reduced physical, sensory or mental capabilities, or lack of experience and knowledge, unless they have been given supervision or instruction concerning use of the lifting unit by a person responsible for their safety.

Children should be supervised to ensure that they do not play with the lifting unit.

1.3. Copyright

This operating and maintenance manual has been copyrighted by the manufacturer. The operating and maintenance manual is intended for use by installation, operating and maintenance personnel. It contains technical regulations and drawings which may not be reproduced or distributed, neither completely nor in part, or used for purposes of competition, or shared with others without the express consent of the manufacturer. Illustrations may differ from the original and serve only as example illustrations of the lifting unit.

1.4. Subject to change

The manufacturer reserves the right to make technical modifications to systems and/or components. This operation and maintenance manual refers to the lifting unit indicated on the title page.

1.5. Warranty

In general, the specifications in the current "General Terms and Conditions" apply to the warranty.

You can find these here:

www.wilo.com/legal

Any deviations must be contractually agreed and shall then be given priority.

1.5.1. General

The manufacturer is obliged to correct any defects found in the lifting units it sells, provided that the defects meet one or more of the following requirements:

- The quality defects were caused by the materials used or the way the device was manufactured and/or designed.
- The defects were reported in writing to the manufacturer within the agreed warranty period.
- The lifting unit was used only as intended.
- All monitoring devices are connected and were tested before commissioning.

1.5.2. Warranty period

The duration of the warranty period is stipulated in the "General Terms and Conditions".

Any deviations must be contractually agreed!

1.5.3. Spare parts, add-ons and modifications

Only genuine spare parts from the manufacturer may be used for repairs, replacements, add-ons and modifications. Unauthorised add-ons and modifications or the use of non-original spare parts can seriously damage the lifting unit and/or seriously injure personnel.

1.5.4. Maintenance

The prescribed maintenance and inspection work should be carried out regularly. This work may only be carried out by qualified, trained and authorised personnel.

1.5.5. Damage to the product

Damage and malfunctions that endanger safety must be eliminated immediately and properly by trained personnel. The lifting unit may only be operated if it is in proper working order.

In general, repairs should only be carried out by the Wilo customer service!

1.5.6. Exclusion of liability

No warranty claims will be accepted or liability will be assumed for lifting unit damage if any of the following items apply:

- Inadequate configuration by the manufacturer due to the information provided by the operator or customer being insufficient and/or incorrect
- Non-compliance with safety instructions and work instructions as specified in this operating and maintenance manual
- Improper use
- Incorrect storage and transport
- Improper installation/dismantling
- Insufficient maintenance
- Incorrect repairs
- Inadequate construction site or construction work
- Chemical, electrochemical and electrical influences

- **Wear**

This means the manufacturer's liability also excludes all liability for personal injury, material damage and/or financial losses.

2. Safety

This section lists all the generally applicable safety instructions and technical information. In addition, all the other sections contain specific safety instructions and technical information. All instructions and information must be observed and followed during the various phases of the lifting unit's life cycle (installation, operation, maintenance, transport, etc.)! The operator is responsible for ensuring that all personnel follow these instructions and guidelines.

2.1. Instructions and safety instructions

This manual uses instructions and safety instructions for preventing personal injury and material damage. To clearly identify them for personnel, the instructions and safety instructions are distinguished as follows:

- Instructions appear in "bold" and refer directly to the preceding text or section.
- Safety instructions are slightly "indented and bold" and always start with a signal word.
 - **Danger**
Serious or fatal injuries can occur!
 - **Warning**
Serious injuries can occur!
 - **Caution**
Injuries can occur!
 - **Caution** (notice without symbol)
Substantial material damage can occur. Irreparable damage is possible!
- Safety instructions that refer to personal injury appear in black and are always accompanied by a safety symbol. Danger, prohibition or instruction symbols are used as safety symbols.
Example:



Danger symbol: General hazard



Danger symbol, e.g. "Electrical current"



Symbol for prohibited action, e.g. "No entry!"



Instruction symbol, e.g. "Wear protective clothing"

The safety symbols used conform to the generally applicable directives and regulations, such as DIN, ANSI.

- Safety instructions that only refer to material damage are printed in grey, without safety symbols.

2.2. General safety information

- The lifting unit must be switched off before any work is performed (installation, dismantling,

maintenance, installation). The lifting unit must be disconnected from the electricity network and secured against reactivation. All rotating parts must have come to a standstill.

- The operator must report any faults or irregularities that occur to a line manager immediately.
- The operator must shut down the equipment immediately if defects occur that represent a safety risk. These include:
 - Failure of the safety and/or monitoring devices
 - Damage to the collection reservoir
 - Damage to electrical equipment, cables and insulation
- Do not work alone when installing and removing the lifting unit in sewage chambers. A second person must always be present. Furthermore, adequate ventilation must be provided.
- Tools and other objects should only be kept in their designated places so that safe operation is ensured.
- When welding and/or working with electrical devices, make sure there is no risk of explosion.
- Only use lifting gear which is legally designated as such and officially approved.
- The lifting gear must be kept safely and must be suitable for the conditions of use (weather, hooking unit, load, etc.).
- Mobile equipment for lifting loads should be used in such a way that it is guaranteed to remain stable during operation.
- When using mobile equipment for lifting non-guided loads, take action to prevent tipping, shifting, sliding etc.
- Measures should be taken to ensure that no person is ever directly beneath a suspended load. Furthermore, it is prohibited to move suspended loads over workplaces where people are present.
- If mobile equipment is used for lifting loads, a second person should be present to coordinate the procedure if required (e.g. if the operator's field of vision is blocked).
- The load to be lifted must be transported so that no-one will be injured if there is a power failure. Furthermore, if such work is being performed outdoors, it must be cancelled if the weather conditions worsen.

These instructions must be strictly observed. Non-observance can result in personal injury and/or substantial material damage.

2.3. Electrical work



DANGER due to electrical voltage!
Improper procedures during electrical work may result in fatal injuries caused by electric shock! This work may only be carried out by a qualified electrician.

CAUTION! Beware of moisture!
Ingress of moisture into the cable will result in damage to the cable and the lifting unit. Never immerse the cable end in fluid and always protect it from moisture. Unused wires must be insulated!

The lifting units are operated with three-phase current. The governing national directives, standards and regulations (e.g. VDE 0100) as well as the requirements of the local energy supply company must be observed.

The control must be via a switchgear to be provided by the customer. The person operating the lifting unit must know where it is supplied with power and how to cut off the supply. A residual-current device (RCD) must be provided.

The section entitled "Electrical connection" must be observed when connecting the product. The technical specifications must be observed strictly! Lifting units must always be grounded.

If the lifting unit has been switched off by a protective device, it must not be switched on again until the fault has been corrected.

When connecting the lifting unit to the local power supply, always comply with the national regulations concerning electromagnetic compatibility (EMC).

If required, take special measures into account (e.g. shielded cables, filters, etc.). Mobile radio equipment may cause malfunctions in the system.



WARNING! Electromagnetic radiation!
Electromagnetic radiation can pose a risk of fatal injury for people with cardiac pacemakers. Put up appropriate signs and make sure anyone affected is aware of the danger!

2.4. Safety and monitoring devices

The sewage lifting unit is equipped with the following safety and monitoring devices:

- Safety device
 - Overflow
 - Monitoring devices
 - Thermal motor monitoring
 - Leakage detection for motor compartment
- The monitoring devices must be connected in a corresponding switchgear.

The personnel must be informed about the installed systems and how they work.

CAUTION!

Never operate the lifting unit if the safety and monitoring devices have been removed or damaged, or if they do not work!

2.5. Conduct during operation

When operating the lifting unit, always follow the locally applicable laws and regulations for work safety, accident prevention and handling electrical machinery.

The motor housing of the sewage pump can reach temperatures of up to 100°C during operation. A corresponding safety zone must be defined by the end-user. No personnel are permitted in this safety zone during operation and no readily flammable and combustible objects may be stored there.

The safety zone must be marked in a way that is unambiguous and clearly recognisable!



CAUTION! Risk of burns!

The motor housing can reach temperatures of up to 100 °C during operation. There is a risk of burns! If personnel are present in the safety zone during operations, then a guard must be installed.

To help ensure safe working practice, the responsibilities of employees should be clearly specified by the operator. All personnel are responsible for ensuring that regulations are observed.

2.6. Fluids

The lifting unit chiefly collects and pumps sewage containing faeces. As a result, changing to a different fluid is not possible.

Use in drinking water is not permitted!

2.7. Sound pressure

Lifting units generate a sound-pressure level of approx. 70 dB(A) during operation.

The sound-pressure level may also be higher during operation depending on several factors (such as installation, attachment of accessories and piping, duty point, etc.).

Therefore, we recommend that the end-user should take an additional measurement at the workplace once the lifting unit is running at its duty point and under all operating conditions.



CAUTION: Wear noise protection!

According to applicable laws and regulations, ear protection must be worn if the sound-pressure level is 85 dB (A) or more! The end-user must make sure that this is complied with!

2.8. Standards and guidelines used

The lifting unit is subject to various European directives and harmonised standards. Refer to the EC-Declaration of conformity for precise information about this.

In addition, various standards are used as a basis for operating, assembling and dismantling the lifting unit.

2.9. CE marking

The CE marking is attached to the rating plate.

3. Product description

The lifting unit has been manufactured with great care and is subject to constant quality controls. Trouble-free operation is guaranteed if the device is installed and maintained correctly.

3.1. Intended use and fields of application



DANGER of explosion!

Gas can collect in the collection reservoir during pumping of sewage containing faeces. This can ignite and lead to an explosion as a result of incorrect installation and operation.

- The collection reservoir must be undamaged (no cracks, leaks, porous material)!
- The inlet and outlet as well as the vent must be connected in accordance with the regulations and be absolutely leak-tight!



DANGER due to explosive fluids!

It is strictly prohibited to pump explosive fluids (petrol, kerosene etc.). The lifting units are not designed for these fluids!

Pumping of untreated sewage that cannot be returned to the sewer system using natural falls, and for the draining of objects that are below the backflow level (according to DIN EN 12056/ DIN 1986-100).

The lifting unit **must not** be used to pump the following:

- Debris, ash, rubbish, glass, sand, plaster, cement, lime, mortar, fibrous materials, textiles, paper towels, wet-wipes (e.g. fleece cloths, moist toilet paper wipes), nappies, cardboard, coarse paper, synthetic resins, tar, kitchen waste, grease, oil
- Slaughterhouse waste, disposal of slaughtered animals and animal waste (liquid manure etc.)
- Toxic, aggressive and corrosive substances, such as heavy metals, biocides, pesticides, acids, bases, salts, swimming-pool water
- Cleaning agents, disinfectants, dishwashing or laundry detergents in excess amounts, and such that have a disproportionately high degree of foam formation
- Sewage from drainage objects that are located above the backflow level and can be drained by natural fall (in accordance with EN 12056-1)
- Explosive media
- Drinking water

The system must be installed in accordance with the general rules as detailed in EN 12056 and DIN 1986-100.

Intended use also includes compliance with this manual. Any other use is regarded as non-intended use.

3.1.1. Application limits



DANGER due to overpressure

Exceeding the application limits can result in excessive pressure in the collection reservoir in the event of system malfunction. This can cause the collection reservoir to burst! There is a health risk due to contact with sewage polluted by bacteria (faeces). Always comply with the application limits and ensure that the inlet is blocked if the system malfunctions.

The following application limits must be observed strictly:

- Max. inlet:
 - CORE 20.2: 20 m³/h
 - CORE 45.2: 45 m³/h
 - CORE 50.2: 50 m³/h
 - CORE 60.2: 60 m³/h

- Max. reservoir flooding during operation: 0 m (tank is depressurised)
- Max. reservoir flooding in case of system failure (measured at tank base):
 - CORE 20.2: 5 m for max. 3 h
 - CORE 45.2, 50.2, 60.2: 6.7 m for max. 3 h
- Max. permitted pressure in the system pressure pipe: 6 bar
- Max. fluid temperature: 40 °C
- Max. ambient temperature: 40 °C

3.2. Structure

The Wilo-EMUport CORE is a submersible and fully automatically operating sewage lifting unit with solids separation system and two submersible sewage pumps in alternating operation without peak-load operation.

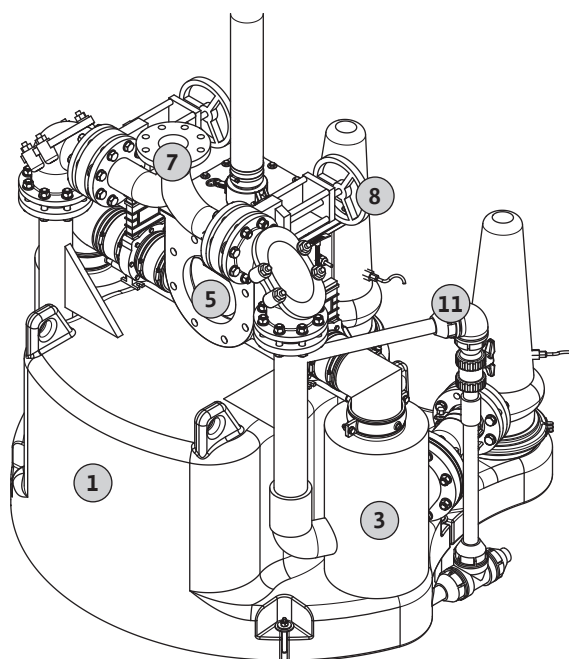
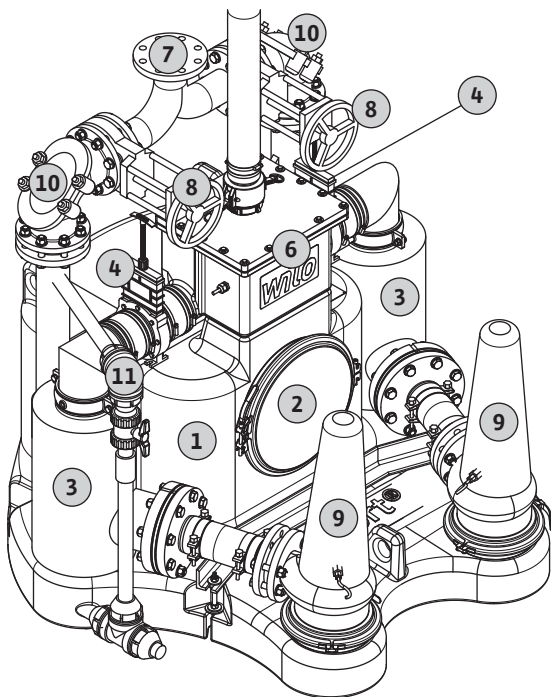

Fig. 1.: Description

1	Collection reservoir
2	Inspection opening of collection reservoir
3	Solids separation reservoir
4	Blocking for the solids separation reservoir
5	Inlet
6	Supply box/distributor
7	Discharge connection
8	Blocking for pressure pipe
9	Sewage pump
10	Non-return valve
11	Manual backwashing

3.2.1. Solids separation system

Solids separation system with all-in-one gastight and watertight collection reservoir without constructive welded joints, as well as two separately blockable solids separation reservoirs.

The collection reservoir has rounded edges, the tank bottom is bevelled, the deepest point is located directly below the pump. This prevents deposits and the drying of solids at critical points. With pre-filtering in the solids separation reservoirs, the solids are filtered from the fluid and only pre-filtered sewage is directed to the collection reservoir.

3.2.2. Sewage pumps

Pumping is performed by two high-performance submersible sewage pumps in dry well installation. The pumps are designed as a redundant system and run in alternating operation.

Simultaneous operation of the two pumps is strictly forbidden!

3.2.3. Level control

The level control is controlled by a level sensor. Measurement range is documented on the rating plate.

3.2.4. Safety and monitoring devices

The sewage lifting unit is equipped with the following safety and monitoring devices:

- Safety device
 - Overflow

The lifting unit is directly connected to the collection reservoir by an overflow in the supply box/distributor. In the event of flooding, the water is channelled directly through this into the collection reservoir after filtration.
- Monitoring devices
 - Thermal motor monitoring

Thermal motor monitoring protects the motor winding from overheating. Bimetallic strip or PTC sensors (FKT 20.2) are used as standard for this.
 - Motor compartment moisture monitoring

The motor compartment monitor signals water ingress into the motor compartment.
 - Sealing chamber moisture monitoring

The sealing chamber monitoring reports water ingress through the fluid-side mechanical seal.
 - Leakage chamber moisture monitoring

The leakage chamber moisture monitor reports any water ingress through the mechanical seal on the motor side.

3.2.5. Materials

- Collection reservoir: PE
- Solids separation reservoir: PE
- Supply box/distributor: PUR
- Pipework: PE
- Pumps: Grey cast iron
- Gate valve: Grey cast iron
- Discharge connection: PUR

3.2.6. Switchgear

The switchgear must be provided by the customer! The necessary functions for the control of a lifting unit with solids separation system must be provided.

Additional information can be found in the chapter "Minimum requirements for the switchgear" on page 20 or contact Wilo customer service with any questions you may have.

3.2.7. Equipment

- Manual backwashing
- Discharge connection with flange connection
- Transparent cover on the supply box/distributor.
- Moisture monitoring for the motor compartment and sealing chamber of the sewage pump.

3.3. Operating principle

The sewage flows through the inlet pipe into the supply box/distributor and from there into one of

the two solids separation reservoirs. The solids separation reservoirs are aligned upstream of the discharge ports of the sewage pumps and "filter out" "non-permitted" large solid materials.

This way, only "pre-cleaned sewage" passes through the idle sewage pump into the shared collection reservoir. When the "Pump ON" water level in the collection reservoir is reached, the pumping procedure of the respective sewage pump is initiated by the level control device.

The sewage pumps run alternately; parallel operation is not permitted!

The volume flow of the working sewage pump opens the separation system of the solids separation reservoir and, as a result of the flow rate, pumps all of the solid materials held back in the solids separation reservoir into the outgoing pressure pipe.

The affected solids separation reservoir is closed with a shut-off ball on the inlet side during this procedure.

3.4. Ex protection

The sewage lifting unit has a closed collection reservoir with dry-mounted pumps. Therefore there is no potentially explosive area present. An explosive atmosphere may prevail within the reservoir due to the accumulation of sewage in the collection reservoir.

Ex Zone 2 is in effect within a radius of 1 m around the ventilation pipe!

In order to prevent explosive atmospheres during maintenance work as well, equipment must be installed in the operating space to enable the air there to be replaced eight times per hour.

3.4.1. Overflow of the lifting unit

The lifting unit is overflow-proof, and can continue to be operated even in a disaster situation.

The electrical connections must be installed accordingly to ensure that they are overflow-proof!

3.5. Operating modes

3.5.1. Operating mode S1 (continuous duty)

The pump can operate continuously at the rated load without exceeding the permissible temperature.

3.5.2. Operating mode S3 (intermittent periodic duty)

This operating mode involves the maximum ratio between operating time and downtime:

S3 50%

Operating time 5 min/downtime 5 min

3.6. Technical data

Approved field of application	
Max. inlet:	CORE 20.2: 20 m ³ /h CORE 45.2: 45 m ³ /h CORE 50.2: 50 m ³ /h CORE 60.2: 60 m ³ /h
Max. permitted pressure in the system discharge pipeline:	6 bar
Max. delivery head [H]:	See unit rating plate**
Maximum volume flow [Q]:	See unit rating plate**
Max. reservoir flooding (above base of tank):	
During operation	0 m
In case of system failure:	CORE 20.2: 5 m/max. 3 h CORE 45.2: 6.7 m/max. 3 h CORE 50.2: 6.7 m/max. 3 h CORE 60.2: 6.7 m/max. 3 h
Fluid temperature [t]:	+3...+40 °C
Ambient temperature:	+3...+40 °C
Motor data	
Mains connection [U/f]:	See unit rating plate**
Power consumption [P ₁]:	See unit rating plate**
Rated power [P ₂]:	See unit rating plate**
Rated current [I _N]:	See unit rating plate**
Activation type [AT]:	See unit rating plate**
System protection class:	IP68
Max. switching operations/h:	30
Cable length:	20 m
Operating mode:	See unit rating plate**
Connections	
Discharge connection:	CORE 20.2: DN 80 CORE 45.2: DN 100 CORE 50.2: DN 100 CORE 60.2: DN 100
Inlet connection:	DN 200, PN 10
Ventilation connection:	DN 70
Dimensions and weights	
Gross volume:	CORE 20.2: 440 l CORE 45.2: 1200 l CORE 50.2: 1200 l CORE 60.2: 1200 l
Switching volume:	CORE 20.2: 295 l CORE 45.2: 900 l CORE 50.2: 900 l CORE 60.2: 900 l
Sound-pressure level*:	< 80 dB(A)
Weight:	See unit rating plate**

* The sound-pressure level depends on the duty point and may vary. Incorrect installation or impermissible operation can increase the sound-pressure level.

*** There are three rating plates on the product:

- 1x unit rating plate
- 2x pump rating plates

3.7. Type key

Example: Wilo-EMUport CORE 20.2-10/540	
CORE	Standardised sewage lifting unit with solids separation system
20	Max. inlet in m ³ /h
2	Number of pumps
10	Maximum delivery head in m at Q = 0
5	Mains frequency 5 = 50 Hz 6 = 60 Hz
40	Mains voltage 40 = 3~400 V 38 = 3~380 V

3.8. Scope of delivery

- Sewage lifting unit ready for connection with 20 m cable and bare cable ends
- Installation and operating instructions

3.9. Accessories (optionally available)

- On the discharge side:
 - Flange connector DN 80
 - Flange connector DN 100
- On the inlet side:
 - FFRc piece of pipe for connecting different inlet pipes
 - Gate valve
 - Inlet sets comprising FFRc piece of pipe and gate valve
 - Flow meter set
 - Flange connectors for connecting pipes without flange connector
- General:
 - Supply box flushing pipe (to automatically flush the supply box)
 - SC-L...-FTS switchgear
 - Horn 230 V, 50 Hz
 - Flash light 230 V, 50 Hz
 - Signal lamp 230 V, 50 Hz

4. Transportation and storage



DANGER due to toxic substances!

Lifting units that pump fluids that are harmful to health must be decontaminated before any other work is performed! Otherwise there is a risk of fatal injury! Wear the necessary protective clothing!

4.1. Delivery

Upon delivery, check immediately that the shipment is complete and undamaged. If any parts are damaged or missing, the transport company or the manufacturer must be notified on the day of delivery since claims cannot be made afterwards. Damage to parts must be noted on the delivery or freight documentation.

4.2. Transportation

Only the designated and approved fastening devices, transportation and lifting equipment may be used for transportation. It must have a sufficient bearing capacity and safe working load in order for the lifting unit to be transported safely. The lifting equipment is not permitted to be fastened anywhere other than to the designated attachment points.

The personnel must be qualified for the tasks and must follow all applicable national safety regulations during the work.

The lifting units are supplied by the manufacturer or supplier in suitable packaging. This normally precludes the possibility of damage occurring during transportation and storage. The packaging should be stored safely for reuse if the product is frequently used at different locations.

4.3. Storage

Newly delivered lifting units are prepared in such a way that they can be stored for at least 1 year. For temporary storage, the lifting units must be thoroughly rinsed with clean water before storage in order to prevent encrustations and deposits building up in the collection reservoir, on the level control device and the pump hydraulics.



DANGER due to toxic substances!

Flushing through the lifting unit contaminates the flushing water with faeces. Risk of fatal injury due to contact with fluid that is harmful to health! Always wear the necessary physical protection equipment and channel the flushing water into the sewer system at suitable points!

The following should be taken into consideration for storage:

- Place the lifting unit securely on a firm bearing surface, and secure it to prevent tipping over and sliding. Lifting units are stored horizontally.
- Lifting units can be stored at temperatures down to $-15\text{ }^{\circ}\text{C}$ if completely emptied. The store room must be dry. We recommend a frost-protected room for storage with a temperature between $5\text{ }^{\circ}\text{C}$ and $25\text{ }^{\circ}\text{C}$.

- The lifting unit is not allowed to be stored in rooms in which welding work is carried out because the resulting gases or radiation can damage the elastomer components.
- All connections must be sealed securely to prevent contamination getting in.
- The connection cable should be protected against kinking, damage and moisture. Furthermore, mounted plugs and switchgear must also be protected against moisture ingress.



DANGER due to electrical voltage!

Defective electrical components (e.g. connection cables, switchgear, plugs) represent a risk of fatal injury due to electric shock! Defective components must be replaced by a qualified electrician immediately.

CAUTION! Beware of moisture!

Ingress of moisture into the electrical components (cables, plugs, switchgear) will result in damage to these components and the lifting unit. Never immerse the electrical components in a liquid, and protect them against the ingress of moisture.

- The lifting unit must be protected from direct sunlight and frost. They can lead to significant damage to the collection reservoir or the electrical components!
- Following prolonged storage, maintenance work in accordance with this Operating and maintenance manual and pursuant to EN 12056-4 must be carried out prior to commissioning. If you comply with these rules, your lifting unit can be stored over a lengthy period. However, note that the elastomer components are subject to natural embrittlement. If the product is to be stored for longer than 6 months, we recommend checking these parts and replacing them as necessary. Consult the manufacturer for further details.

4.4. Return delivery

Lifting units that are sent back to the factory must be cleaned to remove impurities and, if they have been used with fluids that are harmful to health, they must also be decontaminated.

For shipping, the parts must be packed in tear-proof plastic bags of sufficient size in such a manner that they are tightly sealed and leak-proof. Furthermore, the packaging must protect the lifting unit from damage during transportation. If you have any questions, please contact the manufacturer.

5. Installation

In order to prevent damage to the device or serious injury during installation, the following points must be observed:

- Installation work – assembly and installation of the lifting unit – may only be carried out by qualified persons. The safety instructions must be followed at all times.
- The lifting unit must be inspected for transport damage before any installation work is carried out.

5.1. General

For design and operation of technical sewage systems, observe the pertinent local regulations and directives for sewage technology (such as those of the German Association for Water, Wastewater and Waste).

In particular, pressure peaks which occur (e.g., when closing the swing check valve) may be several times higher than the pump pressure, depending on the operating conditions. These pressure surges can cause irreparable damage to the system. **Attention must therefore be paid to the pressure resistance and the longitudinal force fit connection of the pipe.**

Furthermore, the existing piping must be checked to ensure it is correctly connected to the system. The existing pipeline system must be self-supporting and is not allowed to be supported by the lifting unit.

In particular, the following applicable regulations must be complied with for installation of lifting units:

- DIN 1986–100
- EN 12050–1 and EN 12056 (gravity drainage stations within buildings)

Comply with the locally applicable regulations in your country accordingly (e.g. national building regulations)!

5.2. Installation types

- Stationary dry well installation in buildings
- Stationary subsurface installation in pump chambers present on-site

5.3. Installation



DANGER – explosive atmosphere!

An explosive atmosphere can form within the collection reservoir. If the collection reservoir is opened (e.g. maintenance, repair, defect), this atmosphere could spread within the operating space. There is a risk of fatal injury due to explosion! The end-user is responsible for defining a corresponding explosion zone. Observe the following:

- **The lifting unit is not Ex-rated.**
- **Take appropriate countermeasures to avoid an explosive atmosphere in the operating space!**



DANGER due to overpressure

Exceeding the application limits can result in overpressure in the collection reservoir. This can cause the collection reservoir to burst! There is a health risk due to contact with sewage polluted by bacteria (faeces). Ensure that the inlet is blocked if the system malfunctions.

The following application limits must be observed strictly:

- **Max. inlet:**
 - CORE 20.2: 20 m³/h
 - CORE 45.2: 45 m³/h
 - CORE 50.2: 50 m³/h
 - CORE 60.2: 60 m³/h
- **Max. reservoir flooding during operation: 0 m (tank is depressurised)**
- **Max. reservoir flooding in case of system failure (measured at tank base):**
 - CORE 20.2: 5 m for max. 3 h
 - CORE 45.2/50.2/60.2: 6.7 m for max. 3 h
- **Max. permitted pressure in the system pressure pipe: 6 bar**
- **Max. fluid temperature: 40 °C**

The following information must be observed when installing the lifting unit:

- This work must be performed by qualified personnel and electrical work must be performed by a qualified electrician.
- The operating space must be clean, dry, well-lit and free of frost, and furthermore equipped for the respective lifting unit.
- The operating space must be easily accessible. Make sure that there are adequate access opportunities for the transport equipment including the lifting unit, and that any elevators required are sufficiently large and have an adequate bearing capacity.
- Adequate ventilation (eight-fold air replacement) of the operating space must be ensured.
- It is necessary to guarantee that lifting equipment can be installed without difficulty since this will be required for installing/dismantling the lifting unit. The lifting equipment must be able to reach the place where the lifting unit is used and placed without danger. The set-down location must have a solid bearing surface. Transport straps must be used as load-bearing equipment for transporting the lifting unit. These must be fastened to the designated attachment points on the reservoir. The lifting gear used must be technically approved.
- The lifting unit must be easily accessible for operation and maintenance. A space of at least 60 cm must be left clear around the unit (WxHxD).
- The installation surface must be solid (suitable for accommodating dowels), horizontal and flat.
- The placement of any existing or still-to-be installed piping (for inlet, pressure and venting) is to be checked with regard to connection options to the unit.
- A pump sump must be arranged within the operating space for draining it. This must have the

minimum dimensions of 500x500x500 mm. The pump used must be selected according to the delivery head of the lifting unit. In an emergency, it must be possible to drain the pump sump manually.

- Connection cables must be routed in such a way that safe operation and trouble-free installation/dismantling are possible at all times. Never carry or pull the lifting unit by the connection cable! Check whether the cable present is long enough for its cross-section and its installation type.
- The structural components and foundations must be of sufficient stability in order to allow the product to be fixed securely and properly. The operator or the supplier is responsible for provision of the foundations and their suitability in terms of dimensions, stability and strength!
- Check that the available consulting documents (installation plans, layout of the operating space, inlet ratios) are complete and correct.
- Please also observe the applicable national accident prevention and safety regulations of professional and trade associations.
- Also refer to all regulations, rules and laws for working with heavy and suspended loads. Wear appropriate protective clothing/equipment.

5.3.1. Basic advice on the fixation of the lifting unit

Lifting units must be installed so they are prevented from twisting and also in an anti-buoyant

fashion, depending on the installation location. For this purpose, the lifting unit must be anchored to the floor of the operating space. The lifting unit can be installed on various constructions (concrete, steel, etc.). Observe the following instructions for the fixation material:

- Ensure the proper edge clearance in order to prevent the construction material from tearing or chipping.
- The depth of the borehole depends on the length of the screws. The borehole should be 5 mm deeper than the screw length.
- Drilling dust impairs retention force. For this reason, always blow the borehole clean or vacuum it out.
- Make sure the fixation material is not damaged during installation.

5.3.2. Stationary dry well installation in buildings

Work steps

The lifting unit is installed in the following steps:

- Positioning the lifting unit and anchoring it to the floor
- Connecting the pressure pipe
- Connecting the inlet
- Connecting the venting line
- Defining the working area

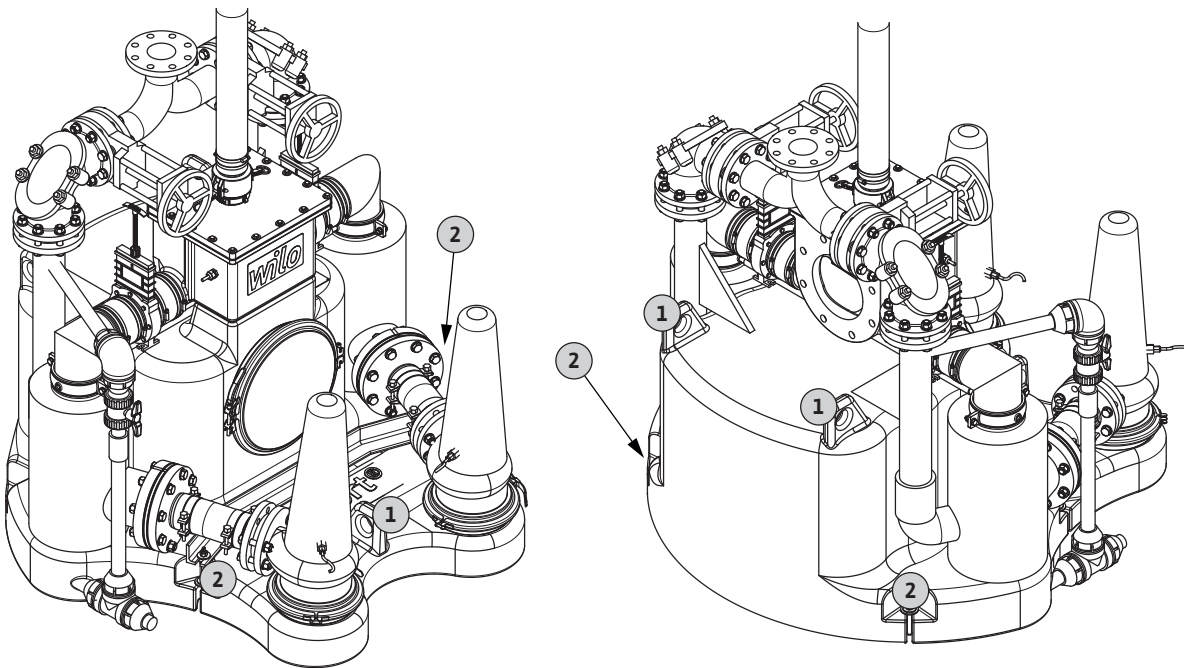

Position the lifting unit and anchor it to the floor!

Fig. 2.: Installing the lifting unit

1	Attachment points
2	Fastening straps

The lifting unit is anchored to the floor with four fixations.

1. Place the lifting unit in the required position and align it.
2. Mark the boreholes.
3. Move the lifting unit to one side and drill the boreholes according to the fixation material used.
4. Reposition the lifting unit and fasten it to the fastening straps with the respective fixation material.

Max. tightening torque: **30 Nm**

Connecting the pressure pipe

BEWARE of pressure peaks!

Pressure peaks can exceed the maximum permitted operating pressure many times over.

This can cause the pressure pipe to burst!

Attempt to avoid pressure peaks by the way that the pressure pipe is routed. The piping and connection elements used must have corresponding pressure resistance!



NOTICE

- According to EN 12056-4, the flow rate at the duty point must be between 0.7 m/s and 2.3 m/s.
- Reducing the pipe diameter in the pressure pipe is not permitted.

The following information must be observed when connecting the pressure pipe:

- The pressure pipe must be self-supporting.
- The pressure pipe must be connected so it is free from vibration, noise-insulated and flexible.
- The connection as well as all unions must be absolutely leak-tight.
- The routing of the pressure pipe must be frost-proof.
- To avoid any backflow from the main public sewer, install the pressure pipe as a loop. The bottom edge of the pipe loop must be above the locally defined backflow level at its highest point.
- Gate valves and non-return valves are already built in. The discharge pipeline can be connected directly.

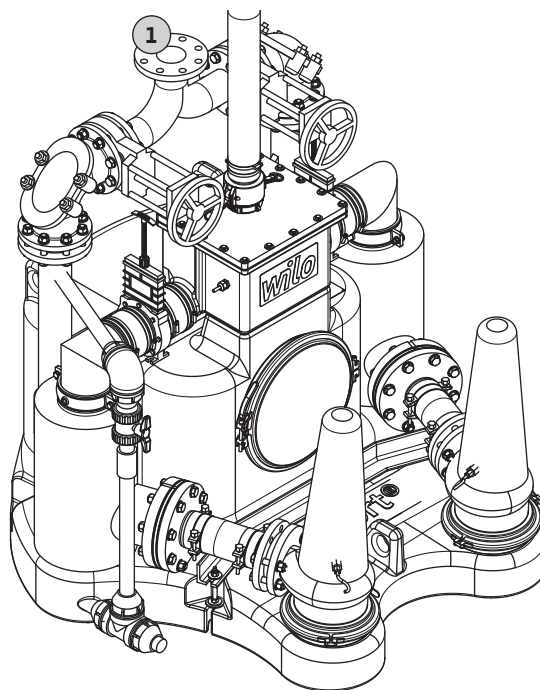

Fig. 3.: Connecting the pressure pipe

1	Discharge connection with flange connection
----------	--

1. Route the pressure pipe so that it is perpendicular to the discharge connection. Refer to the system documentation for the precise dimensions of the lifting unit.
2. Connecting the pressure pipe to the pressure connection:
 - Use a flange connector for flexible and acoustically insulated mounting of the discharge pipeline to the discharge connection.
 - Place a gasket between flange connector and pressure connection.

Max. tightening torque: 45 Nm

Connecting the inlet

The following information must be observed when connecting the inlet pipe:

- The connection is made at the supply box/distributor.
- Install inlet in compliance with valid regulations:
 - Inside buildings: EN 12056
 - Outside buildings: EN 752
- An inlet surge must be prevented as must any air intake.

An inlet surge and/or air intake can cause malfunctions of the lifting unit!

- The connection as well as all unions must be absolutely leak-tight.
- The structure of the inlet must happen with a fall to the supply box/distributor.
- A gate valve must be installed in the inlet upstream of the supply box/distributor!

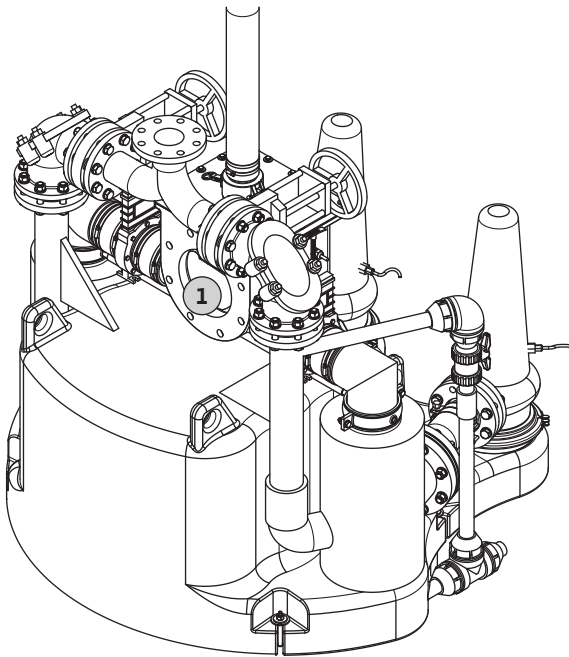

Fig. 4.: Connecting the inlet

1 Inlet connection

1. Route the inlet up to the supply box/distributor.
2. Place a gasket between supply box/distributor and inlet pipe flange.
3. Mount the inlet pipe on the flange of the supply box/distributor.
Max. tightening torque: **45 Nm**

Connecting the venting line

A 2.5 m venting hose with Kamlock coupling is included in the scope of delivery for connecting the venting line. This venting hose must be used so that the cover of the supply box/distributor can be dismantled if necessary.

Comply with the following points when connecting the venting line:

- Connection of a venting line is a specified requirement and essential for correct function of the lifting unit.
- The venting line must be routed via roof and must be provided with gauze and a rain cap 60 cm above the ground surface level.
- The venting line must be self-supporting.
- The venting line must be connected so it is free from vibration.
- The connection as well as all unions must be absolutely leak-tight.

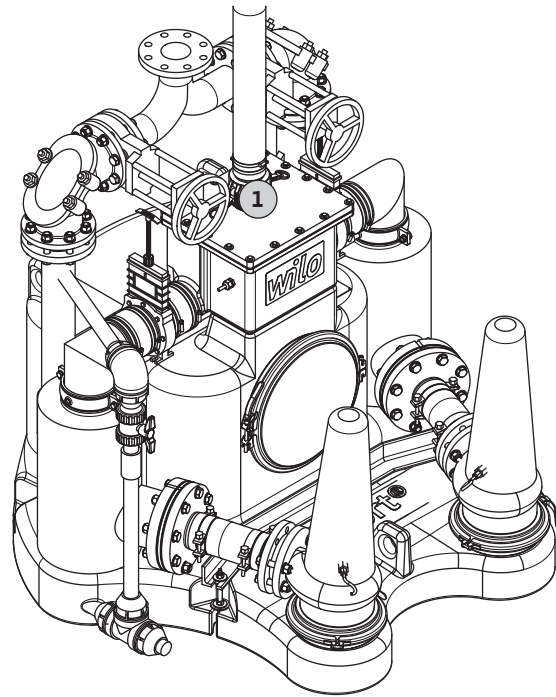

Fig. 5.: Connecting the vent

1 Ventilation connection with hose clip (Kamlock coupling)

1. Attach the venting hose to the hose clip (Kamlock coupling).
2. Open the wings of the hose clip upward and insert the locking pin.
3. Route the venting hose to the stationary venting pipe.
4. Attach 2 hose clips on the venting hose.
5. Push the venting hose onto the ventilation pipe and fasten with the two hose clips.
Max. tightening torque: **5 Nm**

Defining the working area of the system

The motor housing of the sewage pump can reach temperatures of up to 100°C during operation. A corresponding working area must be defined by the end-user. No personnel are permitted in this safety zone during operation and no readily flammable and combustible objects may be stored there.

The working area must be marked in a way that is not confusing and clearly recognisable!

CAUTION! Risk of burns!

The motor housing can reach temperatures of up to 100 °C during operation. There is a risk of burns! If personnel are present in the working area during operations, then a guard must be installed.



5.4. Installation of separately delivered sewage pumps

If the sewage pumps are delivered separately, the sewage pumps have to be installed after the system has been installed.

The sewage pumps are ready to be installed.

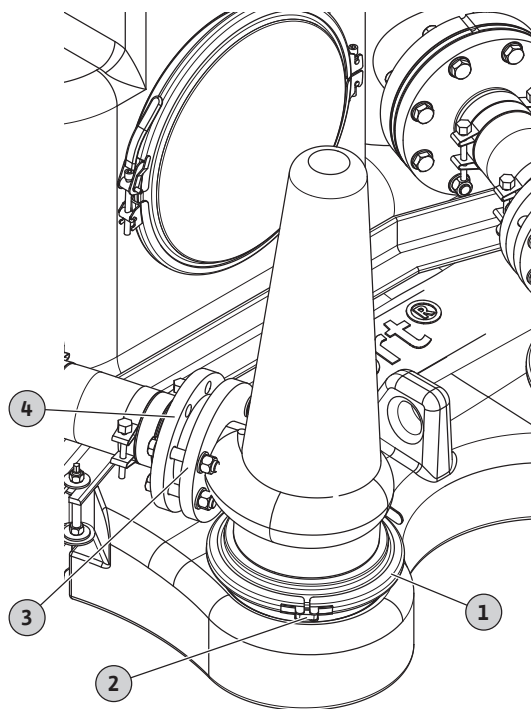

Fig. 6.: Installing the sewage pumps

1	Clamp
2	Clamp fastener
3	Pump discharge connection
4	Pipework connection

1. Loosen clamp fastener.
2. Open clamp.
3. Set sewage pump on opening.
Attach the sewage pump by the handle. See the installation and operating instructions for the sewage pump.
4. Align the discharge connection of the sewage pump to the pipework.
5. Place and lock clamp over both flanges.
Make sure the sewage pump is properly secured. Reposition clamp if necessary.
6. Tighten the clamp fastener. Tightening torque: **15 Nm!**
7. Mount pipework to the discharge connection of the sewage pump. Tightening torque: **45 Nm!**

5.5. Electrical connection



RISK of fatal injury due to dangerous electrical voltage!

Incorrect electrical connections can result in risk of fatal injury! Electrical connection may only be carried out by a qualified electrician approved by the local energy supply company, in accordance with locally applicable regulations.

- The mains connection current and voltage must be as stated on the rating plate.
- Earth the lifting unit according to the regulations. The cross-section of the cable for the protective earth conductor connection must comply with local regulations.
- A residual-current device (RCD) must be installed in accordance with the local regulations!
- The electrical connections must be installed so they are overflow-proof!
- The power supply on the mains side must have a clockwise-rotating field.

5.5.1. Fuse on mains side

The back-up fuse must be rated according to the starting current. You will find the starting current on the rating plate.

Only slow-blow fuses or K-type circuit breakers may be used as a back-up fuse.

5.5.2. Mains connection

The mains connection must be set up on a corresponding switchgear for controlling the lifting unit.

Observe the installation and operating instructions for the respective switchgear!

5.5.3. Connecting the sewage pumps

The attached sewage pumps must be connected to the switchgear in accordance with the wiring diagram.

Position the connection cable of the sewage pump in such a way that the pump can be dismantled at any time from the lifting unit and set down nearby without the connection cable needing to be disconnected from the switchgear!

Fig. 7.: EMUport CORE connection diagrams

A	CORE ...: P 13 motor / direct starting; with 7-core H07RN-F or TGSH connection cable
B	CORE ...: FK 17.1 motor / direct starting; with 7-core H07RN-F connection cable
C	CORE ...: FK 17.1 motor / star-delta activation; with 10-core H07RN-F connection cable
D	CORE ...: FK 202 motor / star-delta activation; with 7-core H07RN-F connection cable and control cable
E	CORE ...: FK 202 motor / star-delta activation; with 2x 4-core NSSHÖU-J connection cable and control cable
F	CORE ...: FKT 20.2 motor / star-delta activation; with 2x 4-core NSSHÖU-J connection cable and control cable

Overview of monitoring devices

EMUport CORE with	Thermal motor monitoring with bimetallic strip	Thermal motor monitoring with PTC sensor	Motor compartment moisture monitoring	Sealing chamber moisture monitoring	Leakage chamber moisture monitoring
P 13... motor	●	○	●	●	-
FK 17.1... motor	●	○	-	●	-
FK 202... motor	●	○	-	●	-
FKT 20.2... motor	-	●	●	-	●
Triggering status if the limit value is reached					
Warning	-	-	-	●	●
Deactivation	●	●	●	○*	○*

Key:

● = as standard ○ = optional - = not available

* Recommended triggering status

Prior to the connection, the insulation resistance of the motor windings and of the monitoring equipment must be checked. If the values measured deviate from the specifications, moisture may have penetrated the equipment or the monitoring unit may be defective. Do not connect the pump and consult Wilo customer service.

Checking the insulation resistance of the motor winding

Use an ohmmeter to check the insulation resistance (measuring voltage = 1000 V). The following values must be complied with:

- At initial commissioning: Insulation resistance may not be less than 20 MΩ.
- For further measurements: Value must be greater than 2 MΩ.

Checking the temperature sensor of the motor winding

Use an ohmmeter to check the temperature sensor. The following values must be complied with:

- Bimetallic strip: Value = "0" passage
- PTC thermistor sensor: A PTC thermistor sensor has a cold resistance of between 20 and 100 Ω. If there are three sensors in series, this results in a value of 60 to 300 Ω. If there are four sensors in series, this results in a value of 80 to 400 Ω.

Checking the moisture sensor in the motor compartment

Use an ohmmeter to check the moisture sensor. The following value must be observed:

- This value must approach "infinity". If the value is low, there is water in the motor compartment.

5.5.4. Connecting the level control device

The level sensor that has been installed must be connected to the respective terminals of the switchgear used. Switching points must be stored in the switchgear in accordance with the data sheet provided with the switchgear:

- Pump ON
- Pump OFF
- High water alarm

The specified switching points may only be changed after consulting the manufacturer! Observe the installation and operating instructions for the respective switchgear!



DANGER – explosive atmosphere!
An explosive atmosphere can form within the collection reservoir. A spark could lead to fatal injury due to explosion! The connection of the level sensor must be made using an intrinsically safe circuit (e.g. Zener barrier). Observe local statutory requirements.

5.5.5. Operation with frequency converters

Operation on the frequency converter is **not** possible.

5.6. Minimum requirements for the switchgear

To ensure safe operation of the sewage lifting unit, the switchgear must provide the following functions and connections.

5.6.1. Functions

- Control of two pumps in alternating operation with forced switching.
Parallel operation is to be prohibited on the hardware-side and software-side!
- Single-pump operation
During maintenance, the lifting unit can be operated with just one pump. The respective pump must be selected to this end and operated in accordance with the specified operating mode!
- Configurable overload protection
- Monitoring the direction of rotation
- Adjustable measurement range for different level sensors
- Main switch
- Manual control of pumps
The pumps may only be switched on if the "Pump ON" level in the collection reservoir has been reached.
- Alarm signal for high water level
An alarm signal must take place when the high-water level is reached.

5.6.2. Connections

- Per pump:
 - Power connection in direct or star-delta activation, dependent on the pump
 - Winding temperature monitoring using bimetallic strip or PTC sensor (FKT 20.2)
 - Moisture probe for the motor compartment monitor
 - Moisture probe for sealing chamber monitoring
- Signal transmitter for the level control device
 - Level sensor
 - Intrinsically safe electric circuit (dependent on local statutory requirements!)

6. Commissioning/operation

The "Commissioning/operation" section contains all the important instructions for operating personnel on commissioning and operating the lifting unit safely.

The following general conditions must always be met and checked:

- Max. inlet/h
- All of the connections are tight, no leakage emerges
- Venting is connected and functioning perfectly
These general conditions must also be checked after a lengthy period of standstill, and any defects detected must be remedied!

Always keep this manual either by the lifting unit or in a place specially reserved for it, where it is accessible for all operating personnel at all times. In order to prevent damage or serious injury when commissioning the lifting unit, the following points must always be observed:

- Electrical engineering and mechanical settings as well as commissioning of the lifting unit are allowed to be carried out only by qualified and trained personnel in accordance with the safety instructions.
- All persons working on or with the lifting unit must have been provided with this manual and have read and understood it.
- All safety devices and emergency cut-outs have been connected to the switchgear that is to be set up on-site and checked to ensure that they work properly.
- The lifting unit is suitable for use under the specified operating conditions.
- When working in pump chambers, a second person must be present. If there is a risk of toxic gases forming, sufficient ventilation must be ensured.

6.1. Commissioning

Commissioning may be carried out only if the installation has been completed and all relevant safety regulations (e.g. VDE regulations in Germany) as well as regional regulations are met.

BEWARE of property damage!

Commissioning must be carried out properly prior to regular operation because otherwise the lifting unit could suffer considerable damage during operation. Perform all of the points properly.

6.1.1. Operation

The operation of the lifting unit takes place using a switchgear to be set up on-site.

See the installation and operating instructions for the switchgear for all the necessary information about operating the switchgear and the individual displays.

6.1.2. Rotation direction monitoring of the sewage pumps

The sewage pumps must be connected clockwise for correct operation of the lifting unit. The rotation direction monitoring must take place via switchgear.

If the direction of rotation is incorrect, then the sewage could be pumped in the collection reservoir under certain circumstances, and this could cause the tank to burst!

6.1.3. Checking the installation

Check the installation to ensure all the necessary work was carried out properly:

- Fixation
 - Floor fixation carried out properly.
- Mechanical connections
 - All of the connections are tight, no leakage emerges.
 - Inlet with shut-off valve.
 - Venting via roof.
- Switchgear
 - Corresponds to the minimum requirements for the operation of a sewage lifting unit with solids separation system.
 - Pumps and level control device are connected in accordance with regulations.
 - Switching points have been stored in the switchgear
- Electrical connection:
 - Clockwise rotating field present.
 - The system is properly protected and earthed.
 - Installation of switchgear and electrical connections is overflow-proof.
 - Orderly placement of connection cable.

6.1.4. Checking the system

Complete the following tasks before commissioning:

- Clean the system, in particular of solid materials and readily flammable objects (e.g. cotton waste).
- Working area of the system is defined and marked in a way that is both unambiguous and clearly recognisable.

6.1.5. Initial commissioning

Before the lifting unit can be taken into operation, it must be filled and a test run must be carried out. The test run must include a complete pump cycle for both pumps.

BEWARE of malfunctions!

Before switching on the switchgear, read the installation and operating instructions and ensure that you are familiar with the switchgear's operation and displays.

1. Switching on the system via the switchgear: Main switch to "ON".
2. Check the switchgear's operating mode. The switchgear should be in automatic mode.
3. Open all of the shut-off devices so that the collection reservoir slowly becomes filled:
 - 1x inlet pipe

- 2x blocking of the solids separation reservoir
- 2x discharge pipeline
- On-site shut-off devices in the pressure pipe if necessary

4. The two sewage pumps must be switched on and off in alternation via the level control device.
5. For a successful test run, both pumps must run through a complete pumping procedure.
6. Close the gate valve in the inlet. In the normal case, the lifting unit should now not switch on again because no more fluid flows in.

If the lifting units should still switch back on again, then the shut-off valve in the inlet or a non-return valve is leaking. Check the installation and consult Wilo customer service.

7. Check to ensure that all pipe joints and the collection reservoir do not leak.
8. If all of the connections and components are free of leaks and if the test run was completed successfully, then the system can be used in regular operations.
9. If the system will not be used immediately in regular operation, then switch the switchgear over to standby mode.



NOTICE

In the event of prolonged system downtime before regular operation, please close all of the shut-off valves and switch off the switchgear.

6.2. Operation

6.2.1. Application limits

The defined utilisation limits must not be exceeded:

- Max. inlet:
 - CORE 20.2: 20 m³/h
 - CORE 45.2: 45 m³/h
 - CORE 50.2: 50 m³/h
 - CORE 60.2: 60 m³/h

The maximum inflow must always be less than the volume flow of the pump at the respective duty point

- Max. reservoir flooding during operation: 0 m
- Max. reservoir flooding in case of system failure (above tank base)
 - CORE 20.2: 5 m for max. 3 h
 - CORE 45.2, 50.2, 60.2: 6.7 m for max. 3 h
- Max. permitted pressure in the system pressure pipe: 6 bar
- Max. fluid temperature: 40 °C
- Max. ambient temperature: 40 °C
- Fluid is present.

Dry running can lead to damage to the motor and is strictly prohibited!

6.2.2. Conduct during operation

When operating the lifting unit, always follow the locally applicable laws and regulations for work safety, accident prevention and handling electrical machinery.

The motor housing of the sewage pump can reach temperatures of up to 100°C during operation. A corresponding working area must be defined by the end-user. No personnel are permitted in this safety zone during operation and no readily flammable and combustible objects may be stored there.

The working area must be marked in a way that is not confusing and clearly recognisable!



CAUTION! Risk of burns!

The motor housing can reach temperatures of up to 100 °C during operation. There is a risk of burns! If personnel are present in the working area during operations, then a guard must be installed.

To help ensure safe working practice, the responsibilities of employees should be clearly specified by the operator. All personnel are responsible for ensuring that regulations are observed.

6.2.3. Regular operation

The lifting unit operates in automatic mode by default and is switched on and off using the integrated level control device.

1. Switching on the system via the switchgear: Main switch to "ON".
2. Check the switchgear's operating mode. The switchgear should be in automatic mode.
3. Check whether all shut-off devices are opened and open any shut-off devices which may be closed:
 - 1x inlet pipe
 - 2x blocking of the solids separation reservoir
 - 2x discharge pipeline
 - On-site shut-off devices in the pressure pipe if necessary
4. The unit now runs in automatic mode.

6.2.4. Overflow of the lifting unit

The lifting unit is overflow-proof, and can continue to be operated even in flooded condition.

6.2.5. Emergency operation in single-pump systems



DANGER due to toxic substances!

During emergency operation, there is potential for contact with fluids that represent a health hazard. The following points must be observed without fail:

- **Wear appropriate full-body protection as well as protective goggles and mouth protection.**
- **Immediately wipe up drips.**
- **Channel the flushing water to a suitable point of the sewer system!**
- **The protective clothing and cleaning cloths must be disposed of acc. to waste code TA 524 02 and EC Directive 91/689/EEC, or acc. to local directives!**

In the event of a fault, the function of the lifting unit can be maintained in emergency operation.

The lifting unit can continue to be operated as a single-pump system to this end.

The following points must be observed if the system is working in emergency operation:

- The inlet in the respective solids separation reservoir must be closed off and the respective pump must be switched off via switchgear.
- The operating mode of the pump must be observed for the operation of the active pump!
- Given that the system continues to be in operation, the collection reservoir will continue to be filled. If the pump is dismantled, then the sewage will be pressed out of the collection reservoir via the connection port!
A shut-off lid for the connection port is available as an accessory for operation without pump. This must be mounted immediately after the pumping procedure!
- The solid materials remain in the solids separation reservoir. They must be disposed of accordingly when the solids separation reservoir is opened.

7. Shutdown/disposal

- All work must be carried out with the greatest care.
- Proper protective clothing is to be worn.
- When working in pump chambers, it is essential to comply with the corresponding local protective measures. A second person must be present for safety reasons.
- Lifting equipment in perfect technical condition and officially approved load-bearing equipment must be used for transporting the lifting unit.



DANGER! Risk of fatal injury due to malfunction!

Lifting gear and lifting equipment must be in perfect technical condition. Work may only commence if the lifting equipment has been checked and is found to be in perfect working order. If it is not inspected, there is a risk of fatal injury!

7.1. Switching off the unit



CAUTION! Risk of burns!

The motor housing can reach temperatures of up to 100 °C during operation. There is a risk of burns! Check the temperature before starting the deactivation. A guard may need to be installed under certain circumstances.

In order for the lifting unit to be taken out of service correctly, the two solids separation reservoirs must be emptied completely. Two complete pump cycles must be run through to this end.

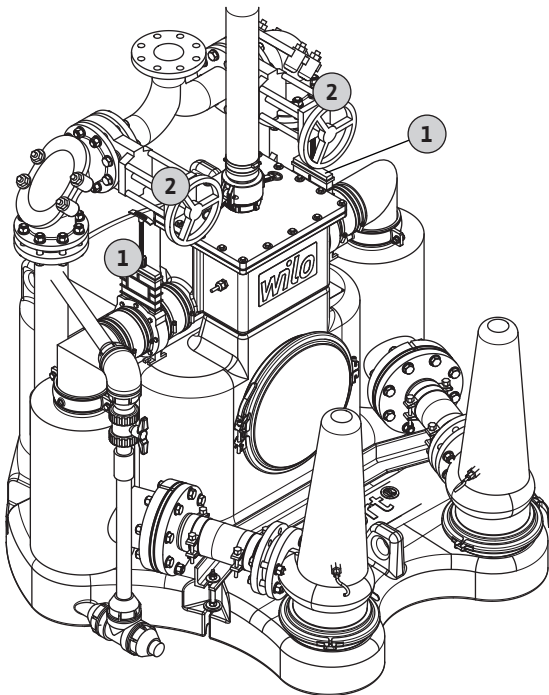

Fig. 8.: Overview of the shut-off devices

1	Solids separation reservoir gate valve
2	Gate valve for pressure pipe

1. Wait until the first pumping procedure has started and been run through completely.
2. Now close the gate valve in the inlet of this solids separation reservoir.
3. Wait until the second pumping procedure starts and has also been run through completely.
4. Close the gate valve in the main inlet.
5. Switch the switchgear to standby mode.
6. Switch off the system at the main switch.
Secure the unit against being unexpectedly switched back on!
7. Close the gate valve on the discharge side.
8. Now it is possible to start the work of removal, maintenance and putting into storage.

7.2. Removal



DANGER due to toxic substances!

During removal, there is potential for contact with fluids that represent a health hazard. The following points must be observed without fail:

- Wear appropriate full-body protection as well as protective goggles and mouth protection.
- Immediately wipe up drips.
- All components must be cleaned and disinfected!
- Channel the flushing water to a suitable point of the sewer system!
- The protective clothing and cleaning cloths must be disposed of acc. to waste code TA 524 02 and EC Directive 91/689/EEC, or acc. to local directives!

Prior to removal and placement in storage, the following maintenance tasks must be carried out in accordance with the "Maintenance and repair" chapter:

- Clean the solids separation reservoirs
 - Clean the collection reservoir and supply box/distributor
- Furthermore, the lifting unit must be flushed out so that the pipework can also be cleaned.
1. Carry out the maintenance tasks in accordance with the "Maintenance and repair" chapter.
 2. Open the gate valves to the solids separation reservoirs in the pressure pipe.
Attention! The gate valve in the inlet pipe must remain closed!
 3. Dismantle the cover on the supply box/distributor.
 4. Restart the system: Switch on the switchgear and switch over to Automatic mode.
 5. Fill the collection reservoir with clean water using a hose through the distributor.
 6. Proceed as described in the section "Switching off the unit" and decommission the system. The lifting unit is flushed with clean water via the two pumping procedures.
 7. Remove the water hose and mount the cover on the supply box/distributor.
 8. Detach the inlet pipe on the flange.

9. Detach the pressure pipe.
10. Detach the ventilation connection and pull off the venting line upwards from the connecting piece.
11. Dismantle the diaphragm hand pump, if present, from the lifting unit.
12. Once all connections have been disconnected, release the anchoring points of the lifting unit in the floor.
13. Now the lifting unit can be pulled carefully out of the pipework.
14. Clean and disinfect the exterior of the lifting unit thoroughly.
15. Clean, disinfect and tightly seal all of the connection pipes.
16. Clean the operating space and disinfect it if necessary.

7.3. Return delivery/storage

Lifting units that are sent back to the factory must be cleaned to remove impurities and, if they have been used with fluids that are harmful to health, they must also be decontaminated.

For shipping, the parts must be packed in tear-proof plastic bags of sufficient size in such a manner that they are tightly sealed and leak-proof. Furthermore, the packaging must protect the lifting unit from damage during transportation. If you have any questions, please contact the manufacturer.

For return delivery and storage, please also refer to the “Transport and storage” section!

7.4. Disposal

7.4.1. Protective clothing

The protective clothing and cleaning cloths must be disposed of acc. to waste code TA 524 02 and EC Directive 91/689/EEC, or acc. to local directives.

7.4.2. Product

Properly disposing of this product will avoid damage to the environment and risks to personal health.

- Use the services of public or private waste disposal companies, or consult them for the disposal of the product or parts thereof.
- For more information about proper disposal, please contact your local council or waste disposal office or the supplier that you obtained the product from.

8. Maintenance and repair



RISK of fatal injury due to electrical current!
There is a risk of fatal injury from electric shock when working on electrical devices. During all maintenance or repair work, the lifting unit must be disconnected from the mains and secured against being switched on again without permission. Any damage to the connection cable should only ever be rectified by a qualified electrician.



DANGER – explosive atmosphere!
An explosive atmosphere can form within the collection reservoir. If the collection reservoir is opened, then this can form inside the operating space. There is a risk of fatal injury due to explosion! Take appropriate countermeasures (e.g. appropriate exchange of air) to avoid an explosive atmosphere in the operating space!
The end-user is responsible for defining a corresponding explosion zone. Observe the following:

- Shutdown the lifting unit in accordance with the chapter “Shutdown/disposal”.
- After maintenance or repair work, the lifting unit must be put back in operation in accordance with the “Commissioning” chapter.

Note the following:

- All maintenance and repair work must be carried out by the Wilo customer service, authorised service workshops or qualified personnel with the greatest of care and in a safe workplace. Proper protective clothing is to be worn.
- This manual must be available to and observed by the maintenance staff. Only maintenance and repair work described in this manual may be carried out.

Any other work and/or alterations to the construction must only be carried out by the Wilo customer service!

- When working in pump chambers, it is essential to comply with the corresponding local protective measures. A second person must be present for safety reasons.
- Lifting equipment in perfect technical condition and officially approved load-bearing equipment must be used for transporting the lifting unit. No lifting forces greater than 1.2 times the pump weight may be applied! The max. permissible bearing capacity must never be exceeded!

Make sure the lifting gear, wire rope and safety devices of the lifting equipment are in perfect working order. Work may only commence if the lifting equipment has been checked and is found to be in perfect working order. If it is not inspected, there is a risk of fatal injury!

- Electrical work on the lifting unit must be carried out by a qualified electrician. Defective fuses must be replaced immediately. These must never

be repaired! Only fuses for the specified electric current and of the specified type may be used.

- If flammable solvents and cleaning agents are used, fire, naked flames and smoking are prohibited.
- Lifting units that circulate fluids that are hazardous to health or come into contact with such fluids must be decontaminated. In addition, make sure that no gases that are hazardous to health form or are present.
- If injuries are caused by fluids or gases that are hazardous to health, apply the first-aid measures specified on the notice at the working premises and notify a doctor immediately!
- Operating fluids (e.g. oils, lubricants, etc.) should be collected in suitable containers and disposed of properly. Also comply with the information in section 7.4 "Disposal"!
- Use only genuine parts from the manufacturer.

8.1. Basic tool equipment

- Torque wrench ¼", 1–25 Nm
 - Socket wrench: 7 / 10 / 13 mm
 - Hexagon socket wrench: 6 mm
- Torque wrench 3/8", 10–100 Nm
 - Socket wrench: 19 / 24 / 30 mm
- Open-end or ring wrench in width across flats 19, 22, 24 and 30 mm
- Pliers set

8.2. Operating fluid

8.2.1. Overview of white oil

The sealing chamber of the sewage pump is filled with white oil that is potentially biodegradable. When changing the oil, we recommend the following oil types:

- ExxonMobile: Marcol 52
- ExxonMobile: Marcol 82
- Total: Finavestan A 80 B (NSF-H1 certified)

8.2.2. P35 coolant

The coolant P35 is a water-glycol mixture consisting of 35% "Fragol Zitrec FC" concentrate and 65% drinking water.

To top up or fill the cooling system, only the named concentrate at the specified ratios may be used.

8.2.3. Filling quantities

The filling quantities depend on the motor type. The motor type is printed on the rating plate of the sewage pump.

Motor	Sealing chamber	Motor	Cooling system
	White oil	White oil	P35
P 13.1	1,100 ml	–	–
P 13.2	1,100 ml	–	–
FK 17.1.../8	480 ml	6,000 ml	–
FK 17.1.../12	480 ml	5,200 ml	–
FK 17.1.../16	480 ml	7,000 ml	–

Motor	Sealing chamber	Motor	Cooling system
	White oil	White oil	P35
FK 202.../12	1,200 ml	6,600 ml	–
FK 202.../17	1,200 ml	7,000 ml	–
FK 202.../22	1,200 ml	6,850 ml	–
FKT 20.2.../30G	–	–	11,000 ml

8.2.4. Overview of lubricating grease

The following lubricating greases can be used in accordance with DIN 51818 / NLGI Class 3:

- Esso Unirex N3
- Tripol: Molub-Alloy Foodproof 823 FM (USDA-H1 approved)

8.3. Logging

Maintenance documentation with the following information is to be kept on file:

- Date of the maintenance
- What was maintenance performed on?
- Was anything conspicuous? Remarks!
- What was replaced?
- Ampere measurement of each pump with clamp-on ammeter shortly before the end of the deactivation point of the pump (detection of wear).
- Name of the maintenance personnel and signature of the responsible individual.

This verification can be used as the basis for guarantee claims and must be handled with care.

8.4. Maintenance intervals

To ensure reliable operation, various maintenance tasks must be carried out regularly.

A log must be kept of all maintenance and repair work, which must be signed by the service employee and the end-user.

NOTICE

We recommend concluding a maintenance contract for regular maintenance work. Please contact Wilo customer service for more information about this.



8.4.1. Maintenance intervals



NOTICE: Intervals pursuant to DIN EN 12056-4 Maintenance schedules and work must be undertaken in accordance with DIN EN 12056-4 when the sewage lifting unit is used inside buildings or areas of land:

- ¼ year in the case of commercial operations
- ½ year for units in multi-family houses
- 1 year for units in single-family houses

After 3 months

- Check the inlet pipe, clean it if necessary

After 6 months

- Check connections for impermeability

- Cleaning the collection reservoir and overflow
If overflows occur regularly, then this must be cleaned **monthly!**

After 12 months

- Clean solids separation reservoir and screen holder

After 24 months

- Oil change of the sewage pump
If using a pencil electrode for sealing chamber monitoring, change the oil in the sealing chamber in accordance with the display.

8.5. Maintenance work

Before carrying out maintenance work:

- Disconnect the lifting unit from the power and secure it against being switched on inadvertently.
- Allow the pump to cool down.
- Immediately wipe up any drips!
- Make sure that all the operationally relevant parts are in good condition.

8.5.1. Checking connections for impermeability

Perform a visual inspection of all pipe connections. If any leakage is found, then these connections must be refurbished immediately.

8.5.2. Checking the inlet pipe and cleaning if necessary

The inlet pipe can be checked and cleaned via the supply box/distributor.

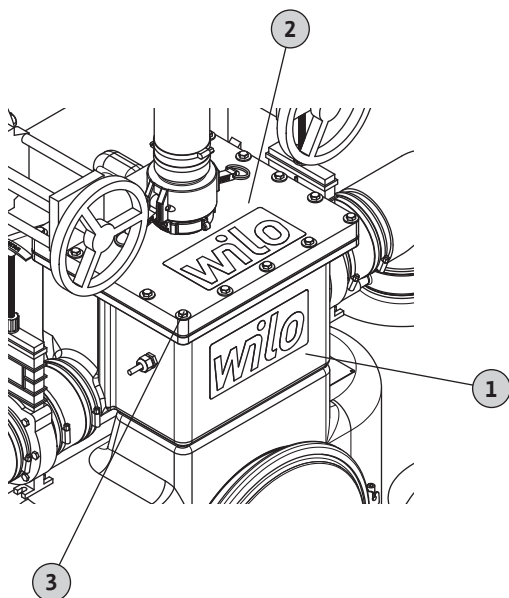

Fig. 9.: Cleaning the inlet

1	Supply box/distributor
2	Cover
3	Screwed connection

1. Undo the screwed connections on the cover of the distributor/supply box.
2. Remove the cover.

3. Check the inlet. Clean the inlet with a water jet if necessary.
4. Put the cover back on and screw the bolts back in. Max. tightening torque: **9 Nm**

8.5.3. Cleaning the collection reservoir and overflow

The cleaning of the collection reservoir and of the overflow must take place in the following sequence:

1. Collection reservoir
 2. Overflow
- This means that the water for the cleaning can be taken up in the collection reservoir and disposed of with the next pumping procedure.

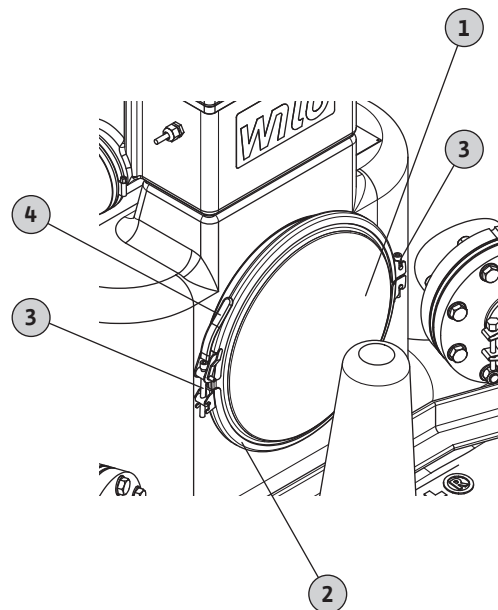

Fig. 10.: Cleaning the collection reservoir

1	Cover of the cleaning opening
2	Clamp
3	Fixation of the clamp
4	Locking lever of the clamp

A cleaning opening is fitted to the front side of the collection reservoir. It is possible to clean the collection reservoir through this opening.

1. Detach the fixation on the clamp.
2. Open the clamp and remove the cover.
3. Clean the collection reservoir with a water jet.
The filling level sensors must not become damaged during cleaning work. Do not point a strong water jet directly at the level sensor!
4. Attach the cover once more and fasten it with the clamp.
5. Tighten the screw for the fixation of the clamp once more.
Max. tightening torque: **15 Nm**

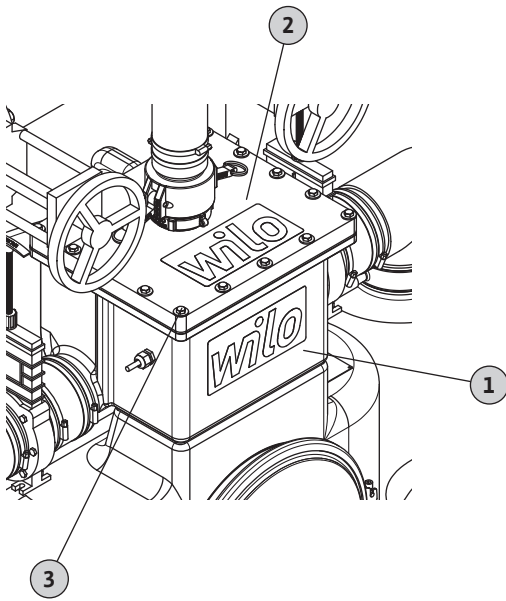

Fig. 11.: Cleaning the overflow

1	Supply box/distributor
2	Cover
3	Screwed connection

The cover on the supply box/distributor can be removed for the cleaning of the overflow.

1. Undo the screwed connections on the cover of the distributor/supply box.
2. Remove the cover.
3. Clean the supply box/distributor with a water jet.
4. Put the cover back on and screw the bolts back in. Max. tightening torque: **9 Nm**

8.5.4. Cleaning the solids separation reservoirs

The solids separation reservoirs are equipped with two screen holders which require cleaning at regular intervals.

At the time of cleaning, it must be noted that the water used for flushing out the screen holders and for cleaning the solids separation reservoirs must be collected accordingly and properly disposed of!

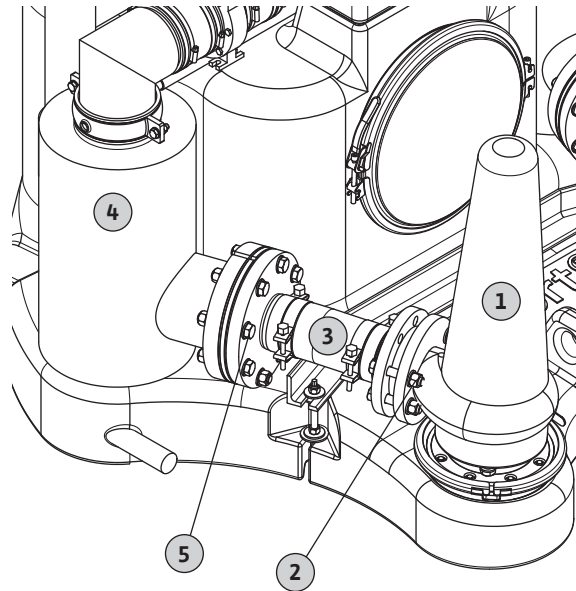

Fig. 12.: Cleaning the solids separation reservoirs

1	Sewage pump
2	Screwed connection at the discharge port of the sewage pump
3	Pump inlet including screen holder
4	Solids separation reservoir
5	Pump inlet/solids separation reservoir screwed connection

1. Undo the screwed connections at the discharge port of the sewage pump.
2. Undo the screwed connections of the pump inlet on the solids separation reservoir.
3. Pull the pump inlet out of the pipework.
4. Remove the screen holders from the connection port of the solids separation reservoir.
5. Use a water jet to clean the solids separation reservoir, the pump inlet and the screen holders.

Attention! The sewage must be collected and channelled to the sewer system in accordance with local regulations!
6. Remove the shut-off ball from the solids separation reservoir and check them for damage. The shut-off ball is to be replaced if
 - the ball is out-of-round
 - there is water inside the ball
 - indentations from the seal kit are to be seen.

Attention! A defective shut-off ball leads to problems during operation.
7. Plug the screen holders back into the connection port of the solids separation reservoir.
8. Insert the pump inlet back into the pipework between the solids separation reservoir and the sewage pump.
9. Fasten the pump inlet to the solids separation reservoir and to the discharge port of the sewage pump with the screwed connections. Max. tightening torque: **45 Nm**

8.5.5. Changing the operating fluid of the sewage pump



WARNING! Risk of injury from hot and/or pressurised operating fluid!
After the hydraulics are switched off, the oil is still hot and pressurised. This can cause the screw plug to be ejected and hot oil to escape. There is a risk of injury or burns! First allow the oil to cool down to ambient temperature.

Different operating fluid must be changed depending on the motor type.

Please refer to the pump's rating plate for the motor type.

EMUport CORE with P 13 motor

The sealing chamber has a hole for draining and filling.

Fig. 13.: Screw plugs

D	Sealing chamber draining and filler hole
---	--

1. Place collection pan underneath the draining screw.
2. Carefully and slowly unscrew the screw plug.
Caution: The operating fluid may be pressurised! This can cause the screw to be ejected at speed.
3. Let operating fluid drain into collection pan.
4. Rinse out sealing chamber with cleaning agent.
5. Dispose of operating fluid in accordance with local requirements.
6. Fill the new operating fluid through the opening for the screw plug. Note the recommended operating fluids and filling quantities!
7. Clean the screw plug, replace the seal ring and screw it back in.

EMUport CORE with FK 17.1 motor

The sealing chamber and the motor compartment have a hole for draining and filling.

Fig. 14.: Screw plugs

D	Sealing chamber draining and filler hole
M	Motor compartment draining and filler hole

1. Place collection pan underneath the draining screw.
2. Carefully and slowly unscrew the screw plug.
Caution: The operating fluid may be pressurised! This can cause the screw to be ejected at speed.
3. Let operating fluid drain into collection pan.
4. Rinse out motor compartment and sealing chamber with cleaning agent.
5. Dispose of operating fluid in accordance with local requirements.

6. Fill the new operating fluid through the opening for the screw plug. Note the recommended operating fluids and filling quantities!
7. Clean the screw plug, replace the seal ring and screw it back in.

EMUport CORE with FK 202 motor

The sealing chamber and the motor compartment each have a separate hole for draining and filling.

Fig. 15.: Screw plugs

D-	Sealing chamber drain hole
D+	Sealing chamber filler hole
M-	Motor compartment drain hole
M+	Motor compartment filler hole
E	Motor compartment vent

1. Place collection pan underneath the draining screw.
2. Carefully and slowly unscrew the screw plug of the drain hole.
Caution: The operating fluid may be pressurised! This can cause the screw to be ejected at speed.
3. Unscrew the screw plug from the filler hole.
During the motor compartment oil change, unscrew the venting screw (E) too!
4. Let operating fluid drain into collection pan.
5. Rinse out motor compartment and sealing chamber with cleaning agent.
6. Dispose of operating fluid in accordance with local requirements.
7. Clean the drain hole screw plug, replace the seal ring and screw it back in.
8. Fill the new operating fluid through the opening for the filler hole. Note the recommended operating fluids and filling quantities!
9. Clean the filler hole screw plug, replace the seal ring and screw it back in.
After the motor compartment oil change, retighten the venting screw (E)!

EMUport CORE with FKT 20.2 motor

The motor has a cooling system. The cooling system is filled with operating fluid P35. The cooling system has a separate opening for draining and filling.

Fig. 16.: Screw plugs

K-	Cooling system drain hole
K+	Cooling system filler hole

1. Place collection pan underneath the draining screw.
2. Carefully and slowly unscrew the screw plug of the drain hole.

Caution: The operating fluid may be pressurised! This can cause the screw to be ejected at speed.

3. Unscrew the screw plug from the filler hole.
4. Let operating fluid drain into collection pan.
5. Rinse out cooling system with cleaning agent.
6. Dispose of operating fluid in accordance with local requirements.
7. Clean the drain hole screw plug, replace the seal ring and screw it back in.
8. Fill the new operating fluid through the opening for the filler hole. Note the recommended operating fluids and filling quantities!
9. Clean the filler hole screw plug, replace the seal ring and screw it back in.

9. Troubleshooting and possible solutions

In order to prevent damage or serious injury when remedying malfunctions on the lifting unit, the following points must always be observed:

- Only attempt to remedy a fault if you have qualified staff, meaning that each job must be carried out by qualified personnel. Electrical work, for example, must be performed by a trained electrician.
- Always secure the lifting unit to prevent it re-starting inadvertently, by disconnecting it from the electrical mains. Take appropriate safety precautions.
- Also comply with the installation and operating instructions provided with the accessories used!
- Unsanctioned modifications to the lifting unit are made at the end-user's own risk and release the manufacturer from any warranty obligations!

9.1. Overview of possible malfunctions

Fault	Identifier for cause and remedy
Lifting unit does not pump	1, 3, 5, 6, 7, 8, 9, 10, 11, 12, 15, 16
Volume flow too low	1, 2, 3, 4, 5, 7, 8, 11, 12, 13
Current consumption too high	1, 2, 3, 4, 5, 7, 13
Delivery head too small	1, 2, 3, 4, 5, 8, 11, 12, 13
Lifting unit runs roughly/ loud noise	1, 2, 3, 9, 12, 13, 14

9.2. Overview of possible causes and their remedies

1. Inlet or impeller clogged
 - Remove deposits from the inlet, reservoir and/or pump ⇒ Wilo customer service
2. Incorrect direction of rotation
 - Exchange 2 phases of the current feed ⇒ Wilo customer service
3. Wear of inner parts (e.g. impeller, bearing)
 - Replace worn parts ⇒ Wilo customer service
4. Operating voltage too low
 - Have the mains connection checked ⇒ electrician
5. Running on two phases
 - Replace defective fuse ⇒ electrician
 - Check the electrical connection ⇒ electrician
6. Motor does not start because there is no voltage
 - Check the electrical connection ⇒ electrician
7. Motor winding or electric cable defective
 - Have the motor and electrical connection checked ⇒ Wilo customer service
8. Swing check valve clogged
 - Clean swing check valve ⇒ Wilo customer service
9. Water level dropped too low in the tank
 - Check level control device and replace if necessary ⇒ Wilo customer service
10. Defective level control signal transmitter
 - Check signal transmitter and replace if necessary ⇒ Wilo customer service
11. Slide valve in the pressure pipe is not open or not sufficiently open

- Fully open the slide valve
- 12. Impermissible amount of air or gas in fluid
 - ⇒ Wilo customer service
- 13. Radial bearing in the motor defective
 - ⇒ Wilo customer service
- 14. System-related vibrations
 - Check elastic connections of the piping ⇒ notify Wilo customer service if necessary
- 15. Winding temperature monitoring switched off due to excessive winding temperature
 - The motor switches back on automatically after the winding has cooled down.
 - Frequent switch-off by the winding temperature monitoring ⇒ Wilo customer service
- 16. Electronic motor protection triggered
 - Rated current exceeded, reset the motor protection using the reset button on the switch-gear
 - Frequent switch-off by the electronic motor protection ⇒ Wilo customer service

9.3. Further steps for troubleshooting

If the points listed here do not rectify the fault, contact Wilo customer service.

Please note that you may be charged for some services provided by our customer service! For more details, please contact Wilo customer service.

9.4. Spare parts

Spare parts can be ordered from the Wilo customer service. To avoid return queries and incorrect orders, the serial and/or article number must always be supplied.

Subject to technical modifications without prior notice!

wilo



Local contact at
www.wilo.com/contact

Pioneering for You

WILO SE
Wilopark 1
44263 Dortmund
Germany
T +49 (0)231 4102-0
F +49 (0)231 4102-7363
wilo@wilo.com
www.wilo.com