

Wilo-Padus UNI



zh-CHS 安装及操作说明

en Installation and operating instructions



Chinese (simplified).....	4
English	22



WILO186776

目录

1	概述	6
1.1	关于本说明书	6
1.2	版权	6
1.3	保留更改权力	6
1.4	保修和免责声明	6
2	安全	6
2.1	安全说明的标识	6
2.2	工作人员资格鉴定	7
2.3	个人防护装备	7
2.4	电气作业	7
2.5	监控装置	7
2.6	危害健康的流体	7
2.7	运输	7
2.8	使用提升设备	7
2.9	安装/拆卸工作	8
2.10	运行期间	8
2.11	清洁和消毒	8
2.12	维护工作	8
2.13	工作介质	8
2.14	运营者的责任	8
3	运输和存放	8
3.1	交货	8
3.2	运输	8
3.3	存放	9
4	应用/使用	9
4.1	规定用途	9
4.2	未按规定使用	9
5	产品说明	10
5.1	说明	10
5.2	材料	10
5.3	技术数据	10
5.4	运行模式	11
5.5	型号代码	11
5.6	供货范围	11
5.7	附件	11
6	安装及电气连接	11
6.1	工作人员资格鉴定	11
6.2	安装方式	11
6.3	运营者的责任	11
6.4	安装	12
6.5	电气连接	13
7	试运行	15
7.1	工作人员资格鉴定	15
7.2	运营者的责任	15
7.3	检查三相交流电机的旋转方向	15

7.4	接通前	15
7.5	接通和关闭.....	15
7.6	运行期间.....	15
8	停止运行/拆卸.....	16
8.1	工作人员资格鉴定.....	16
8.2	运营者的责任	16
8.3	停止运行	16
8.4	拆卸	16
9	维护和维修	18
9.1	工作人员资格鉴定.....	18
9.2	运营者的责任	18
9.3	工作介质.....	18
9.4	维护间隔.....	18
9.5	维护措施.....	18
10	故障、原因和排除方法.....	20
11	备件	21
12	废弃处置	21
12.1	油和润滑剂.....	21
12.2	防护服	21
12.3	关于收集损耗的电气产品和电子产品的相关信息.....	21

1 概述

1.1 关于本说明书

本说明书是产品的固定组成部分。遵守本说明书中列出的要求和操作步骤，是正确操作和使用产品的前提条件：

- 在执行所有工作前请仔细阅读本说明书。
- 请妥善保管说明书，以备随时使用。
- 遵守所有产品相关参数。
- 注意产品上的标识。

原版操作说明书以德语撰写。所有其他语种的说明书均为其翻译件。

可以通过以下产品页面下载数字版安装及操作说明：

<https://qr.wilo.com/798>

1.2 版权

本安装及操作说明的版权归 Wilo 所有。未经允许，禁止对其中的内容进行复制和传播，也禁止出于竞争目的而使用或者透露给他人。

1.3 保留更改权力

Wilo 保留更改所述数据权利，恕不另行通知，对于技术性描述不准确和/或遗漏不承担任何责任。说明书中使用的图片可能与实际设备存在偏差，仅用于举例介绍产品。

1.4 保修和免责声明

Wilo 对于如下情况，不承担任何保修义务或责任：

- 由于运营者或委托方提供的数据存在缺陷或者错误，导致出现配置欠缺问题
- 不遵守本说明书的内容
- 未按规定使用
- 不按规范存放或运输
- 错误安装或拆卸
- 缺乏维护
- 无授权维修
- 安装基础有缺陷
- 化学、电气或电化学影响
- 磨损

2 安全

本章节主要介绍各生命阶段适用的基础提示信息。不遵守提示会导致：

- 人员受伤
- 环境污染
- 物资损失
- 丧失索赔权利

2.1 安全说明的标识

本安装及操作说明针对物资损失和人身安全问题列举了多项安全说明。其表现形式各有不同：

- 涉及到人身安全问题的安全说明以一个信号词作为开端，配套使用相应的符号并使用灰色作为背景色。



危险

危险类型和危险源！

危险产生的影响以及避免危险说明。

- 涉及到物资损失问题的安全说明也以一个信号词作为开端，但是没有符号。

小心

危险类型和危险源！

影响或信息。

信号词

- 危险！
如不注意，会导致死亡或重伤！
- 警告！
如不注意，可能导致人员受伤（重伤）！
- 小心！
如不遵守，可能造成物资损失，甚至导致全损。
- 提示！
操作产品时有用的注意事项

文本说明

✓ 前提条件

1. 操作步骤/细目列举
⇒ 提示/指导
- ▶ 结果

图标

在本说明书中使用以下图标：



电击危险



细菌感染危险



爆炸危险



一般警告图标



切割受伤警告



高温表面警告



高压警告



悬挂物警告



禁止独自工作！必须两人在场。



实用注意事项

2.2 工作人员资格鉴定

- 工作人员必须了解当地现行的事故防范规定。
- 工作人员已阅读安装及操作说明并且理解其中内容。
- 电气作业：受过培训的专业电工
是指接受过相关培训，具备所需知识和经验，能够发现并且规避电力危险的人员。
- 安装/拆卸工作：接受过培训的废水处理技术专业人员
湿井安装和干式地坑安装中的固定件和管道，提升设备，污水设施基础知识
- 保养工作：接受过培训的废水处理技术专业人员
使用/废弃处置用过的工作介质，机械制造基础知识（安装/拆卸）
- 提升工作：接受过提升装置操作培训的专业人员
提升设备，提升装置，吊装孔

儿童和行为能力受限的人

- 未满 16 周岁：禁止使用本产品。
- 未满 18 周岁：在（监管人员）监督下使用！
- 身体、感官或精神上能力不足的人员：禁止使用本产品！

2.3 个人防护装备

规定的防护装备是最低要求。遵守工作规程的相关要求。

防护装备：运输、安装和拆卸以及保养

- 安全鞋：防护等级 S1 (uvex 1 sport S1)
- 防护手套 (EN 388)：4X42C (uvex C500)
- 安全头盔 (EN 397)：符合标准，防止横向变形 (uvex pheos)
(如果使用提升设备)

防护装备：清洁作业

- 防护手套 (EN ISO 374-1): 4X42C + A 型 (uvex protector chemical NK2725B)
- 护目镜 (EN 166)：(uvex skyguard NT)
 - 镜框标记：W 166 34 F CE
 - 镜片标记：0-0.0* W1 FKN CE
 - * 根据 EN 170 的防护等级与此项作业无关。
- 呼吸面罩 (EN 149): 3M 6000 系列半面罩，带过滤器 6055 A2

物品建议

括号中的物品建议仅供参考。可以根据上述标记用结构相同的物品替换！

2.4 电气作业

- 电气作业由专业电工负责执行。
- 将产品断电并采取安全措施防止意外接通。
- 通电时注意遵守当地相关法规。
- 注意遵守当地能源供应公司的相关规定。
- 将电气连接方式等知识告知相关人员。
- 告知相关人员如何关闭产品。
- 遵守本安装及操作说明以及铭牌上给出的技术参数。
- 将产品接地。
- 遵守电气开关设备连接规定。
- 如果使用启动控制器（比如软启动或变频器等），注意遵守电磁兼容性规定。如果需要，考虑采取专业措施（比如使用屏蔽电缆和滤波器等）。

- 更换损坏的接线电缆。请咨询客户服务部。

2.5 监控装置

安装方必须准备下列监控设备：

断路器

断路器的规格和开关属性取决于所连接产品的额定电流。注意遵守当地相关法规。

电机保护开关

对于不带插头的产品，安装方应该准备一个电机保护开关！最低要求是配备一个符合本地规定，具备温度补偿、差分触发和重启动功能的热敏继电器/电机保护开关。针对反应灵敏的电网，安装方还应准备其他保护装置（比如超压、欠压或缺相继电器等）。

漏电断路器 (RCD)

- 根据当地能源供应公司的规定安装漏电断路器 (RCD)。
- 如果人员可能接触到产品和导电液体，则安装漏电断路器 (RCD)。

2.6 危害健康的流体

污水或不流动的积水中会形成有害细菌。可能存在细菌感染危险！

- 穿戴防护装备！
- 拆下之后，应该彻底清洁产品并进行消毒！
- 告知所有工作人员，泵送流体会导致危险！

2.7 运输

- 遵从当地有关作业安全和事故防范措施的现行法律法规。
- 始终应抓握把手搬运产品！

2.8 使用提升设备

如果使用提升设备（提升装置、吊车、环链葫芦等），请注意以下几点：

- 佩戴符合 EN 397 标准的安全头盔！
- 遵守当地有关提升设备的使用规定。
- 确保正确使用提升设备是运营者的责任！
- 提升装置
 - 使用合法且获得认证的提升装置。
 - 根据吊装孔选择提升装置。
 - 按照当地法规将提升装置固定在吊装孔上。
- 提升设备
 - 使用前，检查功能是否正常！
 - 具备足够的承载能力。
 - 确保使用过程中的稳定性。
- 提升过程
 - 防止产品在升降过程中被卡住。
 - 切勿超出允许的最大承载能力！
 - 如果需要（比如视线受阻），安排另外一位工作人员负责协调。
 - 严禁人员在悬挂物下停留！
 - 悬挂物切勿从有人员停留的工作位置上方经过！

2.9 安装/拆卸工作

- 遵从当地有关作业安全和事故防范措施的现行法律法规。
- 将产品断电并采取安全措施防止意外接通。
- 所有旋转零部件均须保持静止。
- 密闭空间保持通风顺畅。
- 在密闭空间内作业时，为安全起见，必须有第二个人在场。
- 在密闭的室内或建筑内有毒气体或窒息气体会不断聚集。遵守工作规程要求的保护措施，例如随身携带气体报警设备。
- 彻底清洁产品。
- 如果在危害健康的流体中使用过该产品，需对产品进行消毒！

2.10 运行期间

- 标记并封锁工作区域。
- 在产品运行期间，禁止任何人在工作区域内停留。
- 通过单独的控制器的流程接通和断开产品。停电之后，产品可能会自动接通。
- 如果电机浮出水面，电机外壳温度可能超过 40 °C (104 °F)。
- 一旦发生故障或者出现异常，立即报告主管。
- 如果产品存在缺陷，立即关闭。
- 切勿探入吸水口中。旋转的部件可能会对身体造成挤压或割伤。
- 打开入口管和压力管中的所有闸阀。
- 通过干转保护确保不会低于最低水浸。
- 声压受多种因素影响（安装、工况点等）。测量运行条件下的当前噪声级。噪声级超过 85 dB(A)，需佩戴耳罩。标记工作区域！

2.11 清洁和消毒

- 使用消毒剂时，需根据生产商说明穿戴防护装备！
- 告知所有工作人员有关消毒剂的信息以及正确使用方法！

2.12 维护工作

- 将产品断电并采取安全措施防止意外接通。
- 彻底清洁产品。
- 如果在危害健康的流体中使用过该产品，需对产品进行消毒！
- 执行保养作业的地点须整洁、干燥、光线充足。
- 只执行本安装及操作说明中列出的保养工作。
- 只使用生产商提供的原装部件。由于使用非原装部件而造成的任何损失，生产商概不承担任何责任。
- 一旦发生流体和工作介质泄露事故，立即收集泄漏物并按照当地现行法规进行废弃处理。

2.13 工作介质

使用以下白油：

- ExxonMobile: Marcol 52
- ExxonMobile: Marcol 82

一般提示

- 立即收集泄漏出的物质。
- 如果发生重大泄漏，请联系客户服务部。

- 如果密封件损坏，油会流入流体中。

急救措施

- 如不慎接触皮肤
 - 用肥皂和水彻底冲洗相应皮肤部位。
 - 如果皮肤发炎，需就医。
 - 如果接触到裸露的皮肤，请就医！
- 如不慎接触眼睛
 - 取下隐形眼镜。
 - 用水彻底冲洗眼睛。
 - 如果眼睛发炎，需就医。
- 如不慎吸入
 - 离开危险区域！
 - 确保空气流通！
 - 如果呼吸道受到刺激、感到头晕或恶心，请立即就医！
- 如不慎吞咽
 - 立即就医！
 - 切勿催吐！

2.14 运营者的责任

- 为工作人员提供以其母语写成的安装及操作说明。
- 为工作人员提供必要的培训，确保其能胜任指派的工作。
- 提供防护装备。保证工作人员穿戴防护装备。
- 使产品上安装的安全和信息标志牌长期保持清晰可读状态。
- 使工作人员了解设备的功能原理。
- 为设备中的危险部件装备触摸防护装置（安装方提供）。
- 标记并封锁工作区域。
- 测量噪声级。噪声级超过 85 dB(A)，需佩戴耳罩。标记工作区域！

3 运输和存放

3.1 交货

- 收到货物之后，立刻检查货物有无缺陷（有无损坏、是否完整）。
- 如有缺陷，标注在运单上！
- 在到货当天，将发现的损坏情况告知运输公司或者生产商。
- 如果不在当天通知，就会丧失索赔权利。

3.2 运输

小心

一旦湿透，包装可能会裂开！

产品会在没有任何保护的情况下跌落地面，致使损毁。请小心提起湿透的包装并立刻进行更换！

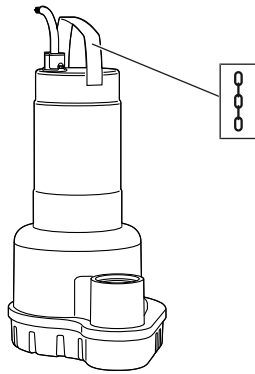

Fig. 1: 吊裝孔

- 穿戴防护装备！遵守工作规程。
 - 防护手套：4X42C (uvex C500)
 - 安全鞋：防护等级 S1 (uvex 1 sport S1)
- 抓握把手搬运水泵！
- 防止接线电缆进水。注意避免连接的插头浸入流体中。
- 为了避免水泵在运输途中受损，到达使用地之后再拆除包装。
- 发运使用过的水泵时，必须使用尺寸足够大而且不易撕破的塑料袋进行包装，包装时注意收口。

3.3 存放



危险
 危害健康的流体会导致危险！
 细菌感染危险！

- 水泵拆卸后做消毒处理！
- 遵守工作规程的相关规定！



警告
 锋利边缘导致受伤危险！
 叶轮和进水口可能形成锋利的边缘。存在割伤危险！

- 佩戴防护手套！

小心

渗入湿气导致全损

液体进入接线电缆会损坏电缆和水泵！切勿将接线电缆端部浸入液体中，存放时须将其牢牢封住。

- 将水泵直立（垂直）放置在坚固的基底上。
- 防止水泵倾翻和移动！
- 水泵最多可存放一年。如果储存时间超过一年，请咨询客户服务部。
- 存放条件：
 - 存储温度范围：-15 °C 至 +60 °C (+5 至 +140 °F)，空气湿度最高：90%，非冷凝。
 - 建议：5 至 25 °C (41 至 77 °F)，相对空气湿度：40 至 50%。

- 保护水泵避免阳光直射。高温会导致损坏！
- 切勿在执行焊接作业的室内存放水泵。因为焊接时形成的气体或辐射可能侵蚀弹性体零件和涂镀。
- 牢牢封闭住吸入接口和压力连接。
- 保护接线电缆，防止其弯折和损坏。注意弯曲半径！
- 每隔一段时间（隔 3-6 个月），将叶轮转动 180°。从而防止轴承无法转动，并更换机械密封的润滑膜。注意！佩戴防护手套！

4 应用/使用

4.1 规定用途

在商业环境中泵送：

- 不含粪便的污水
- 污水（含少量沙子和砂砾）
- pH 值 > 4.5 的微酸性污水
- 潜水泵 Rexa UNI ...B/ 和 Rexa UNI ...K/ 还可泵送：
 - 海水
NaCl 含量（食盐）：最高 30 g/l，温度最高 20 °C
 - 游泳池水，最大氯化物含量：400 mg/l
 - pH 值 > 3.5 的微酸性污水

根据 (DIN) EN 12050 进行废水泵送

水泵符合 EN 12050-2 的要求。

4.2 未按规定使用



危险
 输送爆炸性流体会导致爆炸！
 严禁输送纯粹形态下的易燃易爆流体（汽油、煤油等）。爆炸导致生命危险！水泵不是针对这类流体设计出的产品。

小心

禁止用于沼气应用！

沼气应用中的流体具有强烈的腐蚀性。这些流体会损毁水泵。严禁用于此类应用！

潜水泵不得用于泵送：

- 原污水
 - 含有粪便的污水
 - 饮用水
 - 混杂硬物（比如石头、木材、金属等）的流体
 - 含有大量磨蚀性物质（比如沙子、砂砾等）的流体。
 - 有漂浮物（例如泡沫塑料、木屑）的流体
- 符合规定的使用还包括遵守本说明的规定。任何超出规定范围的应用均视为不合规定。

5 产品说明

5.1 说明

潜水泵适用于间歇运行模式下的固定和移动湿式安装。

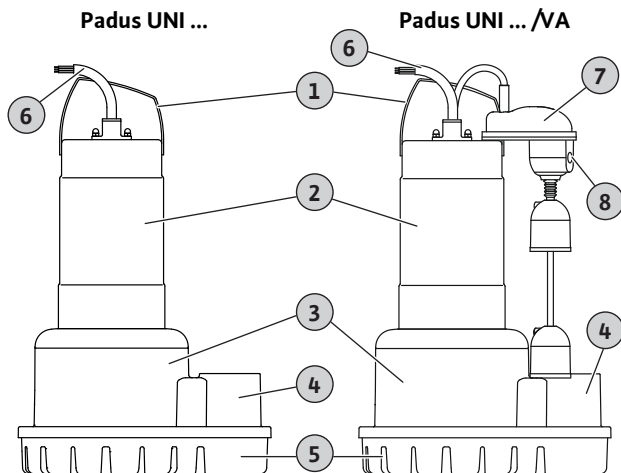

Fig. 2: 概述

1	把手/吊装孔
2	Padus UNI M .../UNI M ...B : 电机外壳 Padus UNI M ...K : 冷却罩
3	水力部件外壳
4	出水口
5	滤网
6	接线电缆
7	立式浮子
8	立式浮子：手动/自动开关

Padus UNI M ... /M .../P

排污泵带开放式多通道叶轮和垂直螺纹连接。水力部件壳体和叶轮使用共聚物制成。表面冷却单相电机，集成有运行电容器和自切换式电机过热保护装置。充油的密封室采用双重密封件。电机外壳由不锈钢制成。可拆分的接线电缆带 Schuko 插头。

Padus UNI M ... /M .../A 和 Padus UNI M ...B/M .../A

排污泵带开放式多通道叶轮和垂直螺纹连接。水力部件壳体和叶轮使用共聚物制成。表面冷却单相电机，集成有运行电容器和自切换式电机过热保护装置。充油的密封室采用双重密封件。电机外壳由不锈钢制成。可拆分的接线电缆带浮子开关和 Schuko 插头。

Padus UNI M ... /M .../VA

排污泵带开放式多通道叶轮和垂直螺纹连接。水力部件壳体和叶轮使用共聚物制成。表面冷却单相电机，集成有运行电容器和自切换式电机过热保护装置。充油的密封室采用双重密封件。电机外壳由不锈钢制成，并安装有立式浮子开关。可拆分的接线电缆带 Schuko 插头。

Padus UNI M ...K/M .../A

排污泵带开放式多通道叶轮和垂直螺纹连接。水力部件壳体和叶轮使用共聚物制成。1~电机（表面冷却），集成有运行电容器和自切换式电机过热保护装置。充油的密封室采用双重密封件。电机外壳和冷却罩使用不锈钢制成。可拆分的接线电缆带浮子开关和 Schuko 插头。

Padus UNI M ... /T .../A

排污泵带开放式多通道叶轮和垂直螺纹连接。水力部件壳体和叶轮使用共聚物制成。表面冷却 3~电机，配备电机过热保护装置。充油的密封室采用双重密封件。电机外壳由不锈钢制成。可分离的连接电缆带有 CEE 插头。浮子开关和电机过热保护装置连接在 CEE 插头上。

Padus UNI M ... /T ... 和 Padus UNI M ...B/T ...

排污泵带开放式多通道叶轮和垂直螺纹连接。水力部件壳体和叶轮使用共聚物制成。表面冷却 3~电机，配备电机过热保护装置。充油的密封室采用双重密封件。电机外壳由不锈钢制成。可分离的连接电缆带裸露的端部。

Padus UNI M ...K/T ...

排污泵带开放式多通道叶轮和垂直螺纹连接。水力部件壳体和叶轮使用共聚物制成。3~电机（表面冷却），配备电机过热保护装置。充油的密封室采用双重密封件。电机外壳和冷却罩使用不锈钢制成。可分离的连接电缆带裸露的端部。

5.2 材料

Wilo-Padus UNI	M ...	M ...B/ ...	M ...K/ ...
水力部件外壳	PP-GF 30	PP-GF 30	PP-GF 30
叶轮	PP-GF 30	PP-GF 30	PP-GF 30
电机外壳	1.4301 (AISI 304)	1.4401 (AISI 316)	1.4401 (AISI 316)
冷却罩	-	-	1.4401 (AISI 316)
轴端	1.4401 (AISI 316)	1.4401 (AISI 316)	1.4401 (AISI 316)

密封件

水泵侧	SiC/SiC	SiC/SiC	SiC/SiC
电机侧	C/Cr	C/Cr	C/Cr
静态	NBR (丁腈橡胶)	NBR (丁腈橡胶)	NBR (丁腈橡胶)

5.3 技术数据

概述

生产日期* [MFY]	见铭牌
电源连接 [U/f]	见铭牌
功耗 [P ₁]	见铭牌
电机额定功率 [P ₂]	见铭牌
最大扬程 [H]	见铭牌
最大流量 [Q]	见铭牌

激活类型 [AT]	见铭牌
流体温度 [t]	3 ... 40 °C (37 ... 104 °F)
短时流体温度	60 °C (140 °F), 持续 3 分钟
防护等级	IP68
绝缘等级 [Cl.]	F
转速 [n]	见铭牌
最大开关频率	60/h
连接有接线电缆时允许的潜水深度 [▽]	见铭牌
最大潜水深度	20 m (66 ft)
电缆长度	10 m (33 ft)
压力连接	
UNI M05 ...	G 2
扩展应用	
防爆	-
在变频器上运行	-

*生产日期书写格式符合 ISO 8601 标准：JJJJWww

- JJJJ = 年份
- W = 周缩写词
- ww = 日历周数据

5.4 运行模式

	UNI M ...	UNI M ...B/ ...	UNI M ...K/ ...
--	-----------	-----------------	-----------------

潜水式 [OTs]

S1	•	•	•
----	---	---	---

非潜水式 [OTe]

S1	-	-	•
S2-15 min	•	•	•
S3 10%	•	•	•

• = 允许, - = 不允许

5.5 型号代码

- 示例：**Wilo-Padus UNI M05B/T15-540/A**
- Padus** 潜水式排污泵
 - UNI** 系列
 - M** 开放式多通道叶轮
 - 05** 压力连接公称直径
 - B** 规格：
 - 无 = 标准规格
 - B = V4A 规格
 - K = 带冷却罩的 V4A 规格

- T** 电源连接规格：
 - M = 1~
 - T = 3~
- 15** /10 = 电机额定功率 P₂, 单位 kW
- 5** 电源连接频率: 5 = 50 Hz, 6 = 60 Hz
- 40** 额定电压代码
- A** 附加电气设备：
 - 无 = 带裸露电缆端部
 - P = 带插头
 - A = 带浮子开关和插头
 - VA = 带立式浮子开关和插头

5.6 供货范围

Padus UNI M ...

- 水泵
- 安装及操作说明

Padus UNI M ...KIT

- 水泵
- 用于 2½" 管道安装的适配器配套元件：
 - 螺纹法兰 2" (外螺纹) 转为 2½" (内螺纹) 用于拧入出水口。出水口连接尺寸：+46 mm。
 - 用于 2½" 管道的橡胶套管 内径：75 mm, 带 2 个管夹。
- 安装及操作说明

5.7 附件

- 接线电缆长度最长 50 m (164 ft)
- 悬挂装置
- 液位控制装置
- 固定附件和链条
- 开关设备、继电器和插头

6 安装及电气连接

6.1 工作人员资格鉴定

- 电气作业：受过培训的专业电工 是指接受过相关培训，具备所需知识和经验，能够发现并且规避电力危险的人员。
- 安装/拆卸工作：接受过培训的废水处理专业技术人员 湿井安装和干式地坑安装中的固定件和管道，提升设备，污水设施基础知识

6.2 安装方式

- 立式固定湿式安装，直接安装在压力管上
- 立式便携式湿式安装

6.3 运营者的责任

- 遵守本地现行的事故防范规定和安全规定。
- 遵守有关处理重物或在悬挂物之下工作的所有法律法规。
- 提供防护装备。保证工作人员穿戴防护装备。
- 进行污水和废水处理时，注意遵守符合当前技术水平的当地相关法规。

- 避免压力冲击！
高压管道较长且有明显的起伏时，可能出现压力冲击。该压力冲击可能导致水泵损坏！
- 根据运行条件和集水坑规格，保证电机冷却时间。
- 建筑/地基必须具有足够的强度，这样才能安全可靠地固定并确保功能正常。准备建筑/地基并保证其适用性，是运营者的责任！
- 检查现有的咨询文件（安装图、安放位置、入口条件）是否齐全和正确。

6.4 安装



危险

独自执行危险作业导致生命危险！

需要在竖井和狭窄空间内完成的工作，以及存在坠落危险的工作，这两个都是危险工种，不允许单人独自作业！

- 作业时必须有另一名工作人员在场！

- 穿戴防护装备！遵守工作规程。
 - 防护手套：4X42C (uvex C500)
 - 安全鞋：防护等级 S1 (uvex 1 sport S1)
 - 安全头盔：EN 397 符合标准，防止横向变形 (uvex pheos)
(使用提升设备的情况下)
- 准备安放位置：
 - 干净，无大颗粒固体物
 - 干燥
 - 不上冻
 - 已消毒
- 工作期间，有毒气体或窒息气体会不断聚集：
 - 遵守工作规程要求的保护措施（随身携带气体测量装置、气体报警设备）。
 - 确保充分的通风。
 - 如果出现有毒气体或窒息气体汇集的情况，立即离开工位！
- 始终抓握把手搬运水泵！
- 放置提升设备：平坦的表面，清洁、牢固的地基。存放地点和安放位置必须易于接近。
- 将链条或钢索通过一个卸扣固定在把手/吊装孔上。只使用建筑技术允许使用的提升装置。
- 按规定铺设所有接线电缆。接线电缆不得引发任何危险（绊倒危险，运行中损坏）。检查电缆横截面和电缆长度对于选择的铺设方式来说是否足够。
- 安装开关设备：注意生产商说明书中的规定（IP 等级、防溢流、潜在爆炸环境）！
- 避免流体内进入空气。在入口使用导流板或偏转板。安装排气装置！
- 禁止水泵空运行！避免进入空气。切勿低于最低水位。建议安装干转保护装置！

6.4.1 维护工作

如果存放时间超过 12 个月，则在开始安装之前，需要进行以下保养作业：

- 检查密封室中的油，必要时更换。
参见章节“给密封室换油 [▶ 19]”。

6.4.2 移动湿式安装

为了确保安全，水泵安装有滤网。因而，水泵可安放在任意安装地点。滤网能过滤掉流体中较大的固体。出口侧连接压力软管。

为避免软地基会出现的下沉问题，在安装地点使用硬底座。

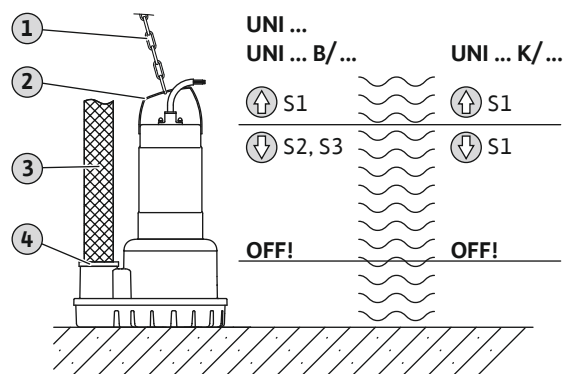

Fig. 3: 便携式湿式安装

1	提升设备
2	把手/吊装孔
3	压力软管
4	软管连接： <ul style="list-style-type: none"> → 带螺纹连接和软管夹的软管喷嘴 → Storz 固定接头
S...	相应水位的运行模式
OFF	最低水位。关闭水泵。

- ✓ 安装地点准备工作已完成。
 - ✓ 压力连接准备工作已完成：软管连接或 Storz 软管接头安装完毕。
 - ✓ 软地基：设有硬底座。
 - ✓ 可固定水泵，防止移动和倾翻。
 1. 如果使用提升设备:将提升设备通过一个卸扣固定在水泵吊装孔上。
 2. 提升水泵，将其放置在使用地点。
 3. 将水泵放在坚固的基底上。避免下沉！
 4. 铺设压力软管并在指定位置（比如排出口）进行正确固定。
 5. 专业铺设接线电缆。小心！切勿损坏接线电缆！
 - 不得有磨损部位或出现弯折。
 - 避免电缆端部浸入流体。
 - 注意弯曲半径。
- ▶ 水泵安装完毕后，进行电气连接。

6.4.3 固定湿式安装

水泵安装在集水坑或水池中。为此，将水泵直接与压力管相连。压力管必须满足以下前提条件：

- 连接的压力管能够自行支撑。压力管不允许由水泵支撑。
- 运行期间，水泵可能会轻微振动。这些振动必须由压力管导入地基中。
- 压力管不允许小于水泵的压力连接。
- 无张力地连接压力管。
- 存在所有规定的阀（闸阀、止回阀等）。
- 压力管已铺设完毕并采取了相应防冻保护措施。
- 排气装置（例如通气阀）已安装好。水泵和压力管中存在空气会导致出现泵送问题。

- ✓ 安装地点准备工作已完成。
- ✓ 存在安装材料（排放管、柔性软管、2个软管夹）。
- ✓ 联轴器法兰已安装在水泵上。

1. 将排放管裁断到所需长度。
 2. 将排放管旋入水泵出水口，并拧到底
 3. 将软管和软管夹套在排放管上。
 4. 将水泵置于排放管下方。
 5. 将软管在压力管和排放管上居中对齐。
 6. 使用软管夹固定软管。注意生产商规定的最大拧紧扭矩！
 7. 将接线电缆固定在压力管上并一直铺设到电源连接处。
- ▶ 水泵安装完毕后，进行电气连接。

6.4.4 液位控制装置

“A”和“VA”型产品装有一个浮子开关。水泵根据液位开关。开关水位如下规定：

- A型：通过电缆长度
- VA型：通过浮子开关在导向杆上的位置

安装时注意以下几点：

- 浮子开关可以任意活动！
 - 不得低于允许的最低水位！
 - 不得超过最大开关频率！
- 为了在液位剧烈波动时达到较大的开关差，液位控制装置配有两个测量点。

VA型：设置切换点

出厂时已将浮子设为最大开关量。必要时可以更改浮子开关的设置。

- ✓ 水泵停止运行。
 - ✓ 水泵断电。
1. 拧松浮子上的内六角螺栓。
 2. 设置所需的切换点：向上或向下推动浮子。
 3. 固定浮子：拧紧浮子上的内六角螺栓。
- ▶ 新的切换点设置完成。

由于缺乏冷却，运行受限

- 上浮子开关设在最上方的切换点。
- 如果将上浮子的切换点向下调整，水泵就不会整个浸入流体中。
- 因而电机无法完全冷却！
- 水泵只能在S3运行模式下进行潜水和非潜水运行！

6.4.5 干转保护

干转保护用于防止出现水泵运行时没有流体，空气进入水力部件的情况。为此，需通过外部控制装置监控允许的最低水位。达到最低水位后，水泵关闭。此外，根据控制装置，还会触发视觉和听觉报警信号。

干转保护可作为附加测量点集成到现有控制装置中。或者，干转保护也可作为唯一的关断装置。视设备安全情况而定，可以自动或手动重启水泵。

建议安装干转保护装置来提高运行可靠性。

6.5 电气连接



危险

触电导致生命危险！

执行电气作业时不按规定操作，会发生电击致死事故！

- 由专业电工负责执行电气作业！
- 遵守当地相关法规！

- 电源连接符合铭牌上的信息。
- 三相交流电机（3~电机）电源侧馈电具备顺时针旋转磁场。
- 按照当地法规的相关要求铺设接线电缆并按照芯线布局进行连接。
- 连接所有监控设备并检查功能是否正常。
- 按照当地法规的相关要求进行接地。

6.5.1 电源一侧的保险丝

断路器

断路器的规格和开关属性取决于所连接产品的额定电流。注意遵守当地相关法规。

电机保护开关

对于不带插头的产品，安装方应该准备一个电机保护开关！最低要求是配备一个符合本地规定，具备温度补偿、差分触发和重启锁定功能的热敏继电器/电机保护开关。针对反应灵敏的电网，安装方还应准备其他保护装置（比如超压、欠压或缺相继电器等）。

漏电断路器 (RCD)

- 根据当地能源供应公司的规定安装漏电断路器 (RCD)。
- 如果人员可能接触到产品和导电液体，则安装漏电断路器 (RCD)。

6.5.2 维护工作

- 检查电机绕组的绝缘电阻。
- 检查温度传感器的电阻器。

6.5.2.1 检查电机绕组的绝缘电阻

- ✓ 1000 V 绝缘测量装置
- ✓ 内置电容器的电机：绕组短路！

1. 检查绝缘电阻。
 - ⇒ 预调试测量值： $\geq 20 \text{ M}\Omega$ 。
 - ⇒ 间隔测量测量值： $\geq 2 \text{ M}\Omega$ 。
- ▶ 绝缘电阻检查完毕。如果测得的数值与规定参数存在偏差，请咨询客户服务部。

6.5.2.2 检查温度传感器的电阻

- ✓ 有电阻表可用。
1. 测量电阻器。
 - ⇒ 双金属片测量值：0 欧姆（连续）。
 - ▶ 电阻器检查完毕。如果测得的数值与规定参数存在偏差，请咨询客户服务部。

6.5.3 单相交流电机（1~电机）连接

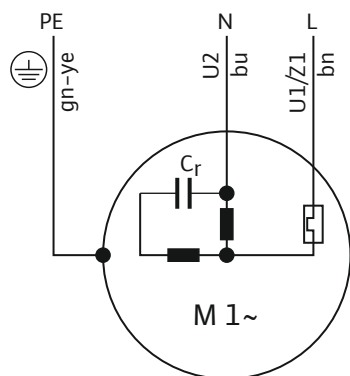

Fig. 4: 1~电机接线图

芯线颜色	端子
棕色 (bn)	L
蓝色 (bu)	N
绿色/黄色 (gn-ye)	接地

水泵配有一个 Schuko 插头。将插头插入插座，即可接入电网。插头不防水。

电机装有双金属片，用作电机过热保护装置。电机过热保护装置是自切换式。不支持单独连接。

如需将水泵直接与开关设备相连，则剪下插头。根据接线图连接开关设备内的接线电缆。

6.5.4 三相交流电机（3~电机）连接

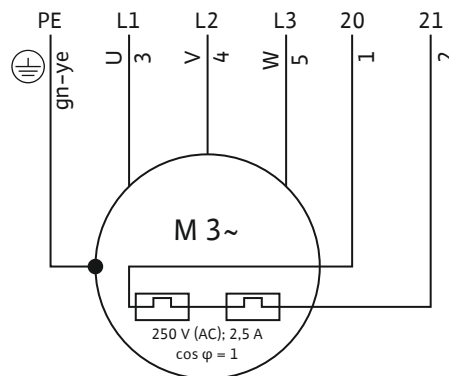

Fig. 5: 3~电机接线图

芯线编号	名称	端子
1	20	WSK
2	21	WSK
3	U	L1
4	V	L2
5	W	L3
绿色/黄色 (gn-ye)	接地	PE

配有插头的水泵

水泵配有一个 CEE 电机保护插头。将插头插入插座，即可接入电网。插头不防水。

电机保护插头连接有电机过热保护装置（双金属片）。达到最高绕组温度后，水泵关闭。必须手动重启。无需单独连接电机过热保护装置。

如需将水泵直接与开关设备相连，则断开插头。根据接线图连接开关设备内的接线电缆。

水泵带裸露电缆端部

- 接线电缆带裸露的端部。
- 根据接线图在开关设备内接线。
- 热电机监控：
 - 双金属片
 - 连接值：最大 250 V(AC), 2.5 A, $\cos \phi = 1$
 - 触发状态：达到最高绕组温度后，水泵关闭！

6.5.5 电机保护设置

6.5.5.1 直接启动

- 满负荷
 - 按照铭牌上的参数将电机保护设置为额定电流。
- 部分负荷
 - 将电机保护设为超过工况点所测电流 5%。

6.5.6 使用变频器运行

运行时不允许使用变频器。

7 试运行



注意

断电后自动接通

通过单独的控制器的根据流程接通和断开产品。在停电之后，可自动接通产品。

7.1 工作人员资格鉴定

→ 操作/控制：操作人员接受了整个系统功能原理的指导

7.2 运营者的责任

- 在水泵上或者指定位置放置安装及操作说明。
- 为工作人员提供以其母语写成的安装及操作说明。
- 保证所有工作人员均已阅读安装及操作说明书并且理解其中内容。
- 设备方面的所有安全装置和紧急停机开关都处于激活状态，并经检查确认功能正常。
- 水泵适合于在规定的工作条件下使用。

7.3 检查三相交流电机的旋转方向

出厂时已将水泵设为正确的旋转方向并经过检查。如果旋转方向正确，则在电源连接处必须存在一个顺时针旋转磁场。水泵不允许在逆时针旋转磁场中运行！

- 检查旋转方向。
使用旋转磁场检测仪检查电源连接处的旋转磁场。
- 校正旋转方向。
交换两相。

7.4 接通前

接通前，请检查以下几项：

- 电气连接是否符合规定？
- 接线电缆的铺设是否牢固？
- 浮子开关能否任意活动？
- 附件是否已正确固定？
- 是否遵守了流体温度？
- 是否遵守了潜水深度？
- 压力管和泵井有无沉积物？
- 压力管路中的所有闸阀是否已打开？
- 压力管中是否有排气装置可用？
水泵和压力管中存在空气会导致出现泵送问题。

7.5 接通和关闭

- 水泵启动时，会短暂超过额定电流。
- 运行过程中不得超过额定电流。

小心！物资损失！如果水泵未启动，立刻关闭水泵。电机损坏！再次接通之前，先排除故障。

采用移动安装方式时，安装注意以下几点：

- 将水泵放在坚固的基底上。避免下沉！
- 如果水泵翻倒，重启前需要先重新放置。
- 如果水泵“跑偏”，将水泵固定在地面上。

水泵装有浮子开关和插头

- 单相交流电机规格（1~电机）

将插头插入插座中，水泵就绪。水泵根据液位自动接通和关闭。

- 三相交流电机规格（3~电机）：
将插头插入插座中，水泵就绪。通过插头上的两个开关控制水泵：
 - HAND/AUTO:设置运行模式。
HAND：手动接通和关闭水泵。AUTO：根据液位自动接通和关闭水泵。
 - ON/OFF:在“HAND”运行模式下接通和关闭水泵。

水泵带立式浮子开关

将插头插入插座后，水泵进入待机状态。水泵根据选择的浮子开关运行模式开关：

- AUTO 运行模式：水泵根据液位开关。
- MANUEL 运行模式：水泵在插入插头后直接启动。

注意！在开关上设置运行模式。开关始终位于上部浮子开关的上方。

水泵装有插头

- 单相交流电机规格（1~电机）：
将插头插入插座中，水泵接通。
- 三相交流电机规格（3~电机）：
将插头插入插座中，水泵就绪。使用 ON/OFF 开关接通和关闭水泵。

水泵带裸露电缆端部

通过单独的现场设置的操作位置（通/断开关，开关设备）来接通和关闭水泵。

7.6 运行期间



警告

旋转部件导致受伤危险！

禁止任何人在水泵工作区域停留。有受伤的危险！

- 标记并封锁工作区域。
- 工作区域无人时，接通水泵。
- 如果有人进入工作区域，立即关闭水泵。



警告

高温表面可能导致烫伤！

电机外壳在运行过程中温度较高，可能导致烫伤。

- 关闭后使水泵冷却到环境温度！

小心

水泵禁止空运行！

禁止水泵干转运行。达到最低水位后，关闭水泵。空运行可能破坏密封件并导致水泵彻底损毁。

**注意****水位过低导致输送问题**

水力部件自排气。泵送过程中触发小型气垫。如果流体降至过低的液位，可能导致输送断流。允许的最低水位必须至少达到水力部件外壳的上边缘！

定期检查以下几项：

- 进水量是否符合水泵输出量。
- 液位控制装置和干转保护装置正确工作。
- 确保最低水浸。
- 确保接线电缆完好无损。
- 水泵无沉积物和结垢现象。
- 无空气进入流体。
- 全部闸阀已打开。
- 安静、无振动运行。
- 未超出最大开关频率。
- 电源连接公差：
 - 工作电压：+/-10 %
 - 频率：+/- 2 %
 - 各相位之间的电耗：最大 5 %
 - 各个相位之间的电压差：最大 1 %

**注意****电机运行期间浮出水面**

- 如果电机在运行过程中浮出水面，注意遵守“非潜水运行模式”的相关规定！参见铭牌上的“OT_e”信息！
- 确保电机在连续运行时得到必要的冷却：在重新接通之前，必须将整个电机没入水中！

S3 10 % 运行模式：如果重启电机前能保证必要的冷却时间，则可执行 S3 25 % 运行模式！为了保证必要的冷却时间，必须将电机整个浸入水中至少 1 分钟！

8 停止运行/拆卸

8.1 工作人员资格鉴定

- 操作/控制：操作人员接受了整个系统功能原理的指导
- 电气作业：受过培训的专业电工是指接受过相关培训，具备所需知识和经验，能够发现并且规避电力危险的人员。
- 安装/拆卸工作：接受过培训的废水处理技术专业人员在湿井安装和干式地坑安装中的固定件和管道，提升设备，污水设施基础知识

8.2 运营者的责任

- 遵守本地现行的同业工伤事故保险联合会事故防范规定和安全规定。
- 遵守有关处理重物或在悬挂物之下工作的法律法规。
- 提供必要的防护装备并保证工作人员佩戴防护装备。
- 在封闭的空间内需提供足够的通风条件。

- 如果出现有毒气体或窒息气体汇集的情况，立刻采取对策！

8.3 停止运行

水泵关闭，但是继续保持组装状态。从而确保水泵随时处于待机状态。

- ✓ 为了保护水泵免遭霜冻和冰冻危害，必须将水泵整个浸入流体中。
- ✓ 最低流体温度：+3 °C (+37 °F)。

1. 关闭水泵。
2. 为操作台采取安全措施（比如锁住主开关），防止意外重启。

▶ 停止水泵运行。

如果水泵在停止运行后继续保持安装状态，注意下列几项要求：

- 在停止运行的整个时段内保证符合上述前提条件。如果不能保证满足前提条件，请将水泵拆除！
- 如果定期长时间停止运行，需要执行一次功能运行：
 - 时间段：每月至每季度
 - 运行时间：5 分钟
 - 必须在有效的工作条件下执行功能运行！

8.4 拆卸

**危险**

危害健康的流体会导致危险！
细菌感染危险！

- 水泵拆卸后做消毒处理！
- 遵守工作规程的相关规定！

**危险**

触电导致生命危险！

执行电气作业时不按规定操作，会发生电击致死事故！

- 由专业电工负责执行电气作业！
- 遵守当地相关法规！

**危险**

独自执行危险作业导致生命危险！

需要在竖井和狭窄空间内完成的工作，以及存在坠落危险的工作，这两个都是危险工种，不允许单人独自作业！

- 作业时必须有另一名工作人员在场！

**警告**

高温表面可能导致烫伤！

电机外壳在运行过程中温度较高，可能导致烫伤。

- 关闭后使水泵冷却到环境温度！

工作时需要穿戴以下防护装备：

- 安全鞋：防护等级 S1 (uvex 1 sport S1)
- 防护手套：4X42C (uvex C500)
- 安全头盔：EN 397 符合标准，防止横向变形 (uvex pheos)
(使用提升设备的情况下)

如果在工作中会接触到危害健康的流体，还应穿戴以下防护装备：

- 护目镜：uvex skyguard NT
 - 镜框标记：W 166 34 F CE
 - 镜片标记：0-0.0* W1 FKN CE
- 呼吸保护面罩：3M 6000 系列半面罩，带过滤器 6055 A2

规定的防护装备是最低要求。遵守工作规程的相关要求！

*根据 EN 170 的防护等级与此项作业无关。

8.4.1 固定湿井安装

- ✓ 停止水泵运行。
- ✓ 入口侧和压力侧的截止阀已关闭。
 1. 断开水泵电源。
 2. 松开压力管上的接线电缆。
 3. 从压力管上松开带排放管的水泵。
 4. 通过把手将水泵从运行空间提出。
 5. 从压力套管上拧下排放管。
 6. 展开接线电缆，固定在电机上。
 - 不要扭结。
 - 不要挤压。
 - 注意弯曲半径。
 7. 彻底清洁水泵和排放管（参见“清洁和消毒”段落）。

8.4.2 移动湿式安装

- ✓ 水泵已停止运行。
 1. 断开水泵电源。
 2. 展开接线电缆，固定在电机上。
 - 不要扭结。
 - 不要挤压。
 - 注意弯曲半径。
 3. 从出水口上松开压力管。
 4. 将提升设备固定在吊装孔上。
 5. 从运行空间中提出水泵。小心！切勿损坏接线电缆！
放下时注意接线电缆！
 6. 彻底清洁水泵（参见“清洁和消毒”段落）。

8.4.3 清洁和消毒

- 穿戴防护装备！遵守工作规程。
 - 安全鞋：防护等级 S1 (uvex 1 sport S1)
 - 呼吸保护面罩：3M 6000 系列半面罩，带过滤器 6055 A2
 - 防护手套：4X42C + A 型 (uvex protector chemical NK2725B)
 - 护目镜：uvex skyguard NT

- 使用消毒剂：
 - 严格按照生产商说明使用！
 - 根据生产商说明穿戴防护装备！
- 根据当地法规废弃处理冲洗水，例如引入污水管道！

✓ 已拆下水泵。

1. 防水地包装好插头或裸露的电缆末端！
2. 将提升设备固定在水泵吊装孔上。
3. 将水泵提升到距离地面大约 30 cm (10 in) 的位置。
4. 从上到下，向水泵喷射清水。
5. 为了清洁叶轮和水泵内部空间，通过出水口向内部喷水。
6. 为水泵消毒。
7. 废弃处理底部的脏污残渣，例如冲入通道。
8. 使水泵干燥。
为了彻底排空水泵壳体，将水泵侧放大约 5 分钟。放置时使出水口朝下。

8.4.3.1 清洁滤网

可以拆下滤网进行清洁。



警告

锋利边缘导致受伤危险！

叶轮和进水口可能形成锋利的边缘。存在割伤危险！

- 佩戴防护手套！

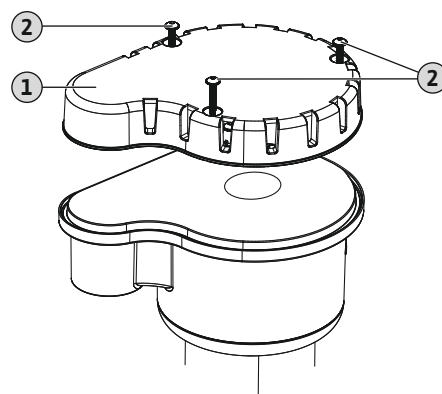

Fig. 6: 拆卸底座

1	滤网
2	紧固螺钉，4号内六角螺栓

1. 将水泵水平放置在坚固的工作台面上。
2. 防止水泵倾翻和移动！
3. 从滤网上拧下紧固螺钉。
4. 取下滤网。
5. 用清水冲洗滤网和水力部件底座，用手清除固体。

6. 放置滤网。
 7. 拧紧紧固螺钉。最大拧紧扭矩：**5.5 Nm (4 ft-lb) !**
- ▶ 滤网已清洁并安装完毕，清洁工作结束。

9 维护和维修

9.1 工作人员资格鉴定

- 电气作业：受过培训的专业电工是指接受过相关培训，具备所需知识和经验，能够发现并且规避电力危险的人员。
- 保养工作：接受过培训的废水处理技术专业人员使用/废弃处置用过的工作介质，机械制造基础知识（安装/拆卸）

9.2 运营者的责任

- 提供必要的防护装备并保证工作人员佩戴防护装备。
- 使用合适的容器收集工作介质并按规定进行废弃处理。
- 按规定对使用过的防护服进行废弃处理。
- 只使用生产商提供的原装部件。由于使用非原装部件而造成的任何损失，生产商概不承担任何责任。
- 一旦发生流体和工作介质泄露事故，立即收集泄漏物并按照当地现行法规进行废弃处理。
- 提供需要使用的工具。
- 使用易燃溶剂和清洁剂时，应禁止明火、明灯和吸烟。
- 须在设备的检修表中记录保养工作。

9.3 工作介质

9.3.1 油类型

- ExxonMobile: Marcol 52
- ExxonMobile: Marcol 82
- Total: Finavestan A 80 B（经过NSF-H1认证）

9.3.2 加注量

加注量为 1200 ml (40 US.fl.oz)。

9.4 维护间隔

- 定期执行保养作业。
- 根据实际环境条件按合同调整保养间隔。联系客户服务部。
- 如果在运行过程中出现剧烈振动，检查安装情况。

9.4.1 一般工作条件下的维护间隔

1500 个运行小时数或者 **5** 年后

- 目检接线电缆
- 目检附件
- 目检涂层和壳体
- 检查监控设备的功能
- 密封室换油
- 补充调整叶轮间隙

5000 个运行小时数或者 **10** 年后

- 大修

9.4.2 恶劣条件下的维护间隔

在以下操作条件下，请咨询客户服务缩短规定的保养间隔：

- 流体中含有长纤维成分
- 涡流式入口（例如由于空气进入、气蚀）
- 强腐蚀性或磨蚀性流体
- 会生成大量气体的流体
- 在不合适的工况点运行
- 压力冲击

在恶劣条件下使用水泵时，建议签订保养合同。

9.5 维护措施



警告

锋利边缘导致受伤危险！

叶轮和进水口可能形成锋利的边缘。存在割伤危险！

- 佩戴防护手套！

开始采取保养措施之前，满足下列前提条件：

- 穿戴防护装备！遵守工作规程。
 - 安全鞋：防护等级 S1 (uvex 1 sport S1)
 - 防护手套：4X42C (uvex C500)
 - 护目镜：uvex skyguard NT
 有关镜框和镜片的详细标记请参见“个人防护装备 [▶ 7]”一章。
- 水泵已彻底清洁并消毒。
- 电机已冷却到环境温度。
- 工作位置：
 - 洁净、照明和通风良好。
 - 工作台面坚固稳定。
 - 有保护装置，防止摔倒和滑倒。

注意！只执行本安装及操作说明中列出的保养作业。

9.5.1 目检接线电缆

检查接线电缆的以下几方面：

- 气泡
- 裂纹
- 划痕
- 摩擦情况
- 挤压情况

如果接线电缆损坏：

- 立即停止运行水泵！
- 联系客户服务部更换接线电缆！

小心！物资损失！水会通过损坏的接线电缆进入电机。电机进水会导致水泵彻底损毁。

9.5.2 目视检查附件

附件必检项：

- 是否正确固定
- 功能是否正常
- 有无磨损症状，比如振动导致的裂纹

一旦确定存在缺陷，必须立刻维修或者更换附件。

9.5.3 目检涂层和壳体

涂层和壳体不得有任何损伤。如果确定存在缺陷，注意下面几项：

- 修补损坏的涂层。请在客户服务部订购维修套件。
- 如果壳体磨损，请咨询客户服务部！

9.5.4 检查监控设备的功能

检查电阻之前，必须先将水泵冷却至环境温度！

9.5.4.1 检查温度传感器的电阻

- ✓ 有电阻表可用。
- 1. 测量电阻器。
 - ⇒ 双金属片测量值：0 欧姆（连续）。
- ▶ 电阻器检查完毕。如果测得的数值与规定参数存在偏差，请咨询客户服务部。

9.5.5 给密封室换油



警告

工作介质承受压力！

电机内部会形成高压！打开螺旋塞时，这种压力会向外冲出。

- 如果打开螺旋塞时不注意，它可能会高速弹出！
- 可能会喷射出高温工作介质！

- ⇒ 穿戴防护装备！
- ⇒ 执行任何作业之前，应先将电机冷却到环境温度！
- ⇒ 遵守规定的工作步骤顺序！
- ⇒ 缓慢旋出螺旋塞。
- ⇒ 开始泄压之后（可听见空气鸣叫声或嘶嘶声），不要继续转动螺旋塞！
- ⇒ 待泄压完成之后，才能完全拧出螺旋塞。

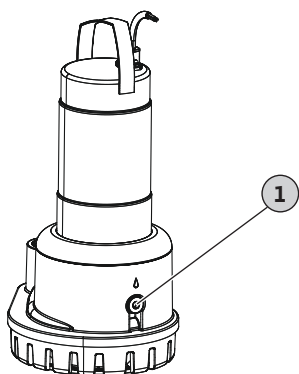

Fig. 7: 密封室：换油

1	密封室螺旋塞
---	--------

- ✓ 防护装备就位！
- ✓ 水泵已拆卸、清洁完毕，并完成消毒处理。

1. 将水泵水平放置在坚固的工作台面上。螺旋塞朝上。
2. 防止水泵倾翻和移动！
3. 缓慢旋出螺旋塞。
4. 泄压完成之后，完全拧出螺旋塞。
5. 放置合适的容器用于收集工作介质。
6. 排放工作介质：转动水泵，直到开口朝下为止。
7. 检查工作介质：
 - ⇒ 工作介质清澈：工作介质可重复使用。
 - ⇒ 工作介质脏污（黑色）：注入新的工作介质。
 - ⇒ 工作介质呈乳白色/浑浊：油中有水。机械密封造成的少量泄漏属于正常现象。如果油与水的比例小于 2:1，那么可能损坏机械密封。进行换油并在 4 周后再次检查。如果再次有水进入油中，则通知客户服务部！
 - ⇒ 工作介质中有金属屑：通知客户服务部！
8. 注入工作介质：转动水泵，直到开口朝上为止。通过开口注入工作介质。
 - ⇒ 遵守规定的工作介质类型和数量！
9. 清洁螺旋塞，装入新密封环，重新拧入。最大拧紧扭矩：8 Nm (5.9 ft-lb)！

9.5.6 补充调整叶轮间隙

输送污水和废水时，可能导致叶轮磨损，致使水泵输送功率降低。为了对叶轮磨损进行补偿，可以补充调整叶轮和进水口之间的间隙。

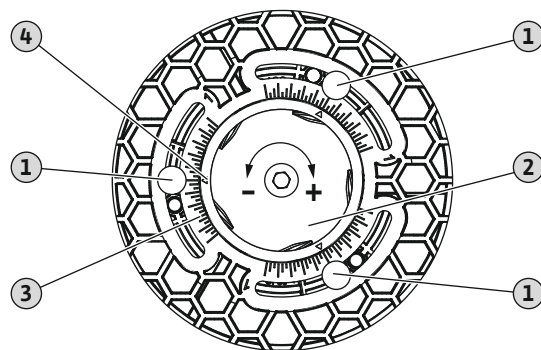

Fig. 8: 补充调整叶轮间隙（已拆下滤网）

1	用于固定间隙调整装置的紧固螺栓
2	间隙调整装置
3	刻度盘
4	读取标记 (▲)
+	扩大间隙
-	缩小间隙

- ✓ 已拆下滤网。参见“清洁滤网 [▶ 17]”
- ✓ 已清洁底座。刻度盘和读取标记清晰可读。

1. 拧松紧固螺栓，直至间隙调整装置能转动为止。注意！切勿完全拧出螺栓！
 2. 向左转动间隙调整装置(-)，直至支承板贴在叶轮上。
 3. 将间隙扩大3个刻度：向右转动间隙调整装置(+)。调整时注意读取标记！
 4. 拧紧紧固螺栓。最大拧紧扭矩：**4 Nm (3 ft-lb)!**
- 叶轮间隙修正完毕。安装滤网。

9.5.7 大修

大修时检查下列部件的磨损和损坏情况：电机轴承、轴封、O形圈和接线电缆。使用原装件更换损坏的部件。如此可保证正常运行。

大修由生产商或者授权的维修厂执行。

10 故障、原因和排除方法



警告

旋转部件导致受伤危险！

禁止任何人在水泵工作区域停留。有受伤的危险！

- 标记并封锁工作区域。
- 工作区域无人时，接通水泵。
- 如果有人进入工作区域，立即关闭水泵。

故障：水泵不启动

1. 电源线断开或者导线/电机绕组发生短路/对地短路。
 - ⇒ 安排专业电工检查接线和电机，必要时进行更换。
2. 触发保险丝、电机保护开关或监控设备
 - ⇒ 安排专业人员检查接线和监控设备，必要时进行改动。
 - ⇒ 安排专业电工按照技术规定安装电机保护开关和保险丝并进行设置，重置监控设备。
 - ⇒ 检查叶轮的灵活性，必要时清洁水力部件

故障：水泵启动后，很快就触发电机保护

1. 电机保护开关设置错误。
 - ⇒ 安排专业电工检查触发器设置并进行修正。
2. 高电压降导致高电耗。
 - ⇒ 安排专业电工检查各相位的电压值。联系电网运营商。
3. 接线只有两相。
 - ⇒ 安排专业电工检查接线并进行修正。
4. 相位之间电压差异大。
 - ⇒ 安排专业电工检查各相位的电压值。联系电网运营商。
5. 旋转方向错误。
 - ⇒ 安排专业电工修正接线。

6. 水力部件堵塞导致高电耗。
 - ⇒ 清洁水力部件，检查入口。
7. 流体密度过高。
 - ⇒ 联系客户服务部。

故障：水泵运行，无流量

1. 无流体。
 - ⇒ 检查入口，打开所有截止阀。
2. 入口堵塞。
 - ⇒ 检查入口，清除堵塞。
3. 水力部件堵塞。
 - ⇒ 清洁水力部件。
4. 出口侧管道系统或压力软管堵塞。
 - ⇒ 消除堵塞，必要时更换损坏的部件。
5. 间歇运行。
 - ⇒ 检查开关设备。

故障：水泵启动，但是达不到工况点

1. 入口堵塞。
 - ⇒ 检查入口，清除堵塞。
2. 出口侧滑阀关闭。
 - ⇒ 完全打开所有截止阀。
3. 水力部件堵塞。
 - ⇒ 清洁水力部件。
4. 旋转方向错误。
 - ⇒ 安排专业电工修正接线。
5. 管道系统中形成气垫。
 - ⇒ 为管道系统排气。
 - ⇒ 频繁形成气垫：寻找进气口，避免进气，必要时在指定位置安装排气装置。
6. 水泵输送背压过高。
 - ⇒ 完全打开出口侧的所有截止阀。
7. 水力部件出现磨损迹象。
 - ⇒ 检查部件（叶轮、进水口、水泵壳体）并联系客户服务部进行更换。
 - ⇒ 叶轮间隙过大。补充调整叶轮间隙。
8. 出口侧管道系统或压力软管堵塞。
 - ⇒ 消除堵塞，必要时更换损坏的部件。
9. 流体生成大量气体。
 - ⇒ 联系客户服务部。
10. 接线只有两相。
 - ⇒ 安排专业电工检查接线并进行修正。
11. 运行期间，液位剧烈降低。
 - ⇒ 检查系统供应/容量。
 - ⇒ 检查液位控制装置的切换点，必要时进行调整。

故障：水泵运行不安静，噪声大

1. 不允许的工况点。
⇒ 检查水泵布局和工况点，咨询客户服务部。
2. 水力部件堵塞。
⇒ 清洁水力部件。
3. 流体生成大量气体。
⇒ 联系客户服务部。
4. 接线只有两相。
⇒ 安排专业电工检查接线并进行修正。
5. 旋转方向错误。
⇒ 安排专业电工修正接线。
6. 水力部件出现磨损迹象。
⇒ 检查部件（叶轮、进水口、水泵壳体）并联系客户服务部进行更换。
7. 电机轴承磨损。
⇒ 联系客户服务部；水泵返厂维修。
8. 水泵已夹紧安装。
⇒ 检查安装情况，必要时安装橡胶补偿器。

其他故障排除方法

如果所述方法于故障排除无益，请联系客户服务部。客户服务部门可如下提供帮助：

- 通过电话或邮件提供帮助。
- 提供现场支持。
- 返厂检查和维修。

如果向客户服务部门提出支援请求，可能会产生费用！具体金额请咨询客户服务部。

11 备件

请在客户服务部订购备件。为了减少询问，同时避免出现订购错误，请提供序列号或商品号。保留技术变更权利！

12 废弃处置

12.1 油和润滑剂

工作介质必须被收集到一个适当的容器中，并根据当地现行的指令废弃处置。一旦有介质滴落，立刻进行收集！

12.2 防护服

穿过的防护服必须根据当地现行的指令废弃处置。

12.3 关于收集损耗的电气产品和电子产品的相关信息

按规定废弃处置和正确回收这些产品，能避免环境污染、保护人身健康。



注意

禁止作为生活垃圾废弃处置！

在欧盟地区，该标志张贴在产品、包装或随附的资料中。它的意思是，相关的电气和电子产品不得作为生活垃圾废弃处置。

在按规定处理、回收和废弃处置相关旧产品时，要注意以下几点：

- 这些产品只能交给专门为此设立且获得认证的垃圾处理场。
- 注意当地现行的规定！

有关按规定废弃处置的信息，请咨询当地社区、最近的垃圾处理场或您购买产品的经销商。关于回收的详细信息请访问 www.wilo-recycling.com。

保留技术变更权利！

Table of contents

1	General information	24
1.1	About these instructions	24
1.2	Copyright	24
1.3	Subject to change	24
1.4	Exclusion from warranty and liability	24
2	Safety	24
2.1	Identification of safety instructions.....	24
2.2	Personnel qualifications.....	25
2.3	Personal protective equipment.....	25
2.4	Electrical work	25
2.5	Monitoring devices	25
2.6	Fluids hazardous to health.....	26
2.7	Transport.....	26
2.8	Use of lifting equipment	26
2.9	Installing/dismantling.....	26
2.10	During operation	26
2.11	Clean and disinfect	26
2.12	Maintenance tasks.....	26
2.13	Operating fluid	26
2.14	Operator responsibilities.....	27
3	Transportation and storage	27
3.1	Delivery.....	27
3.2	Transport.....	27
3.3	Storage	27
4	Application/use	28
4.1	Intended use	28
4.2	Improper use.....	28
5	Product description	28
5.1	Description.....	28
5.2	Materials.....	29
5.3	Technical data	29
5.4	Operating modes.....	30
5.5	Type key.....	30
5.6	Scope of delivery.....	30
5.7	Accessories	30
6	Installation and electrical connection	30
6.1	Personnel qualifications.....	30
6.2	Installation types.....	30
6.3	Operator responsibilities.....	30
6.4	Installation	31
6.5	Electrical connection	32
7	Commissioning.....	34
7.1	Personnel qualifications.....	34
7.2	Operator responsibilities.....	34
7.3	Direction of rotation check for three-phase AC motor	34

7.4	Before switching on	34
7.5	Switching on and off	34
7.6	During operation	35
8	Shut-down/dismantling	36
8.1	Personnel qualifications	36
8.2	Operator responsibilities	36
8.3	Shut-down	36
8.4	Removal	36
9	Maintenance and repair	38
9.1	Personnel qualifications	38
9.2	Operator responsibilities	38
9.3	Operating fluid	38
9.4	Maintenance intervals	38
9.5	Maintenance measures	38
10	Faults, causes and remedies	40
11	Spare parts	41
12	Disposal	42
12.1	Oils and lubricants	42
12.2	Protective clothing	42
12.3	Information on the collection of used electrical and electronic products	42

1 General information

1.1 About these instructions

These instructions form part of the product. Compliance with the instructions is essential for correct handling and use:

- Read the instructions carefully before all activities.
- Keep the instructions in an accessible place at all times.
- Observe all product specifications.
- Observe the markings on the product.

The language of the original operating instructions is German. All other languages of these instructions are translations of the original operating instructions.

A digital version of the Installation and Operating Instructions can be downloaded from the following product page:

<https://qr.wilo.com/798>

1.2 Copyright

These installation and operating instructions have been copyrighted by Wilo. Content of any kind must not be reproduced, distributed or used by unauthorised persons for purposes of competition and shared with others.

1.3 Subject to change

Wilo shall reserve the right to change the listed data without notice and shall not be liable for technical inaccuracies and/or omissions. The illustrations used may differ from the original and are intended as an example representation of the device.

1.4 Exclusion from warranty and liability

Wilo shall specifically not assume any warranty or liability in the following cases:

- Inadequate configuration due to inadequate or incorrect instructions by the operator or the client
- Non-compliance with these instructions
- Improper use
- Incorrect storage or transport
- Incorrect installation or dismantling
- Insufficient maintenance
- Unauthorised repairs
- Inadequate construction site
- Chemical, electrical or electrochemical influences
- Wear

2 Safety

This section contains basic information about the individual stages in the life cycle of the pump. Failure to observe this information leads to:

- Danger to persons
- Danger to the environment
- Property damage
- Loss of claims for damages

2.1 Identification of safety instructions

These installation and operating instructions set out safety instructions for preventing personal injury and damage to property. These safety instructions are shown differently:

- Safety instructions relating to personal injury start with a signal word, are **preceded by a corresponding symbol** and are shaded in grey.



DANGER

Type and source of the danger!

Consequences of the danger and instructions for avoidance.

- Safety instructions relating to property damage start with a signal word and are displayed **without** a symbol.

CAUTION

Type and source of the danger!

Consequences or information.

Signal words

→ **DANGER!**

Failure to observe the safety instructions will result in serious injuries or death!

→ **WARNING!**

Failure to follow the instructions can lead to (serious) injuries!

→ **CAUTION!**

Failure to follow the instructions can lead to property damage and a possible total loss.

→ **NOTICE!**

Useful information on handling the product

Markups

✓ Prerequisite

1. Work step/list

⇒ Notice/instructions

► Result

Symbols

These instructions use the following symbols:



Danger caused by electric voltage



Danger of bacterial infection



Danger of explosion



General warning symbol



Warning – risk of cutting injuries



Warning – hot surfaces



Warning – high pressure



Warning – suspended loads



Working alone is prohibited! A second person must be present.



Useful information

2.2 Personnel qualifications

- Personnel have been instructed on locally applicable regulations governing accident prevention.
- Personnel have read and understood the installation and operating instructions.
- Electrical work: qualified electrician
Person with appropriate technical training, knowledge and experience who can identify and prevent electrical hazards.
- Installation/dismantling work: trained sewage technology professional
Fixation and pipework in wet well and dry well installation, lifting equipment, basic knowledge of wastewater facilities
- Maintenance work: trained sewage technology professional
Application/disposal of operating fluids used, basic engineering knowledge (installation/dismantling)
- Lifting work: trained specialist for the operation of lifting devices
Lifting equipment, lifting gear, attachment points

Children and persons with limited abilities

- Persons under the age of 16: Use of this product is prohibited.
- Persons under the age of 18: Supervise them during use of the product (supervisor)!
- Persons with limited physical, sensory or mental capacities: Use of this product is prohibited!

2.3 Personal protective equipment

The protective equipment specified is the minimum requirement. Observe the requirements of the work regulations.

Protective equipment: Transport, installation, removal and maintenance

- Safety shoes: Protection class S1 (uvex 1 sport S1)
- Protective gloves (EN 388): 4X42C (uvex C500)
- Safety helmet (EN 397): Conforms to standards, protection against lateral deformation (uvex pheos)
(If lifting equipment is used)

Protective equipment: Cleaning work

- Protective gloves (EN ISO 374-1): 4X42C + Type A (uvex protector chemical NK2725B)
- Safety goggles (EN 166): (uvex skyguard NT)
 - Labelling frame: W 166 34 F CE

- Labelling disc: 0-0.0* W1 FKN CE
 - * Protection level according to EN 170 not relevant for this work.
- Breathing protection mask (EN 149): Half mask 3M series 6000 with filter 6055 A2

Article recommendations

The articles mentioned in brackets are recommendations. The articles can be replaced with an identical article according to the mentioned labellings!

2.4 Electrical work

- Electrical work must be carried out by a qualified electrician.
- Disconnect device from the mains and secure it against being switched on again without authorisation.
- Observe applicable local regulations when connecting to the mains power supply.
- Comply with the requirements of the local energy supply company.
- Train personnel on how to make electrical connections.
- Train personnel on the options for switching off the device.
- Observe the technical information in these installation and operating instructions as well as on the rating plate.
- Earth the device.
- Observe provisions for connection to the electrical switching system.
- Comply with the specifications on electro-magnetic compatibility when using electronic start-up controllers (e.g. soft starter or frequency converter). If required, take special measures into account (e.g. shielded cables, filters, etc.).
- Replace defective connection cables. Contact customer service.

2.5 Monitoring devices

The following monitoring devices must be provided on-site:

Circuit breaker

The size and switching characteristics of the circuit breakers must conform to the rated current of the connected product. Observe local regulations.

Motor protection switch

Make provision for an on-site motor protection switch for devices without a plug! The minimum requirement is a thermal relay/motor protection switch with temperature compensation, differential triggering and anti-reactivation device in accordance with the local regulations. In case of sensitive mains, make provision for the installation on-site of other protective equipment (e.g. over-voltage, undervoltage or phase failure relay, etc.).

Residual-current device (RCD)

- Install a residual-current device (RCD) in accordance with the regulations of the local energy supply company.
- If people can come into contact with the device and conductive fluids, install a residual-current device (RCD).

2.6 Fluids hazardous to health

Hazardous germs form in sewage or in stagnant water. There is a danger of bacterial infections!

- Wear protective equipment!
- Clean and disinfect the product thoroughly after removal!
- Inform all persons about the pumped fluid and the danger it poses!

2.7 Transport

- Locally applicable laws and regulations on work safety and accident prevention must be complied with.
- Always carry the product by the handle!

2.8 Use of lifting equipment

If lifting equipment (lifting device, crane, chain hoist ...) is used, observe the following points:

- Wear a safety helmet according to EN 397!
- Comply with local regulations on the use of lifting equipment.
- The technically correct use of the lifting equipment is the operator's responsibility!
- **Lifting gear**
 - Use legally specified and approved lifting gear.
 - Select lifting gear based on the attachment point.
 - Attach lifting gear to the attachment point according to local regulations.
- **Lifting equipment**
 - Check its functions properly before use!
 - Sufficient bearing capacity.
 - Ensure stability during use.
- **Lifting operation**
 - Do not jam the product when lifting and lowering it.
 - Do not exceed the max. permissible bearing capacity!
 - If necessary (e.g. blocked view), assign a second person to coordinate.
 - No one should stand under suspended loads!
 - Do not move loads over workplaces where persons are present!

2.9 Installing/dismantling

- Locally applicable laws and regulations on work safety and accident prevention must be complied with.
- Disconnect device from the mains and secure it against being switched on again without authorisation.
- All rotating parts must stop.
- Ensure enclosed spaces have sufficient ventilation.
- When working in enclosed spaces, a second person must be present for safety reasons.
- Toxic or asphyxiating gases may build up in enclosed spaces or buildings. Observe protective measures in accordance with work regulations, e.g. carry a gas detector with you.
- Clean the device thoroughly.
- If the product has been used in fluids that are hazardous to health, disinfect the product!

2.10 During operation

- Demarcate and cordon off the working area.
- No persons are allowed in the working area during operation.
- Depending on the process, the product is activated and deactivated using separate controls. The product may automatically be activated following power cuts.
- If the motor emerges, the motor housing can heat up to above 40 °C (104 °F).
- Superior must be informed immediately of any faults or irregularities.
- The product must be switched off immediately if faults occur.
- Never reach into the suction port. The rotating parts can crush and sever limbs.
- Open all gate valves in the inlet and pressure pipe.
- Ensure minimum water submersion by using dry-running protection.
- Sound-pressure level depends on several factors (installation, duty point, etc.). Measure the current noise level under operating conditions. Wear hearing protection at noise levels of 85 dB(A) and over. Demarcate the working area!

2.11 Clean and disinfect

- If a disinfectant is used, wear protective equipment according to the manufacturer's instructions!
- Inform all persons about the disinfectant and how to use it correctly!

2.12 Maintenance tasks

- Disconnect device from the mains and secure it against being switched on again without authorisation.
- Clean the device thoroughly.
- If the product has been used in fluids that are hazardous to health, disinfect the product!
- Carry out maintenance work in a clean, dry and well-lit place.
- Only carry out maintenance tasks described in these installation and operating instructions.
- Only original parts of the manufacturer may be used. The use of any non-original parts releases the manufacturer from any liability.
- Collect any leakage of fluid and operating fluid immediately and dispose of it according to the locally applicable guidelines.

2.13 Operating fluid

The following white oils are used:

- ExxonMobile: Marcol 52
- ExxonMobile: Marcol 82

General remarks

- Absorb leakages immediately.
- If major leakages occur, contact customer service.
- If the seal is defective, the oil enters the pumped fluid.

First aid measures

- **Skin contact**
 - Rinse skin areas thoroughly with soap and water.

- If skin irritation occurs, consult a doctor.
- In case of contact with open skin, consult a doctor!

→ Eye contact

- Remove the contact lenses.
- Rinse eye thoroughly with water.
- If eye irritation occurs, consult a doctor.

→ Inhalation

- Remove from the contact area!
- Create air exchange!
- If the respiratory tract becomes irritated or there is dizziness or nausea, consult a doctor immediately!

→ Ingestion

- Consult a doctor **immediately!**
- **Do not** induce vomiting!

2.14 Operator responsibilities

- Provide installation and operating instructions in a language which the personnel can understand.
- Make sure that the personnel have received the required training for the specified work.
- Provide protective equipment. Ensure that the protective equipment is worn by personnel.
- Ensure that safety and information signs mounted on the device are always legible.
- Train the personnel on how the system operates.
- Fit dangerous components within the system with an on-site guard.
- Demarcate and cordon off the working area.
- Measure the noise level. At noise levels of 85 dB(A) and over, wear hearing protection. Demarcate the working area!

3 Transportation and storage

3.1 Delivery

- After receiving the shipment, check it immediately for defects (damage, completeness).
- Defects must be noted on the freight documentation.
- Defects must be notified to the transport company or the manufacturer on the day of receipt of shipment.
- Subsequently notified defects can no longer be asserted.

3.2 Transport

CAUTION

Soaked packaging may tear!

The product may fall on the ground if unprotected and may be damaged. Lift wet packaging carefully and replace it immediately!

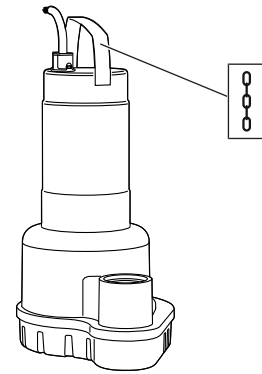

Fig. 1: Attachment point

- Wear protective equipment! Observe the work regulations.
 - Protective gloves: 4X42C (uvex C500)
 - Safety shoes: Protection class S1 (uvex 1 sport S1)
- Carry the pump by the handle!
- Protect the connection cable against water ingress. Do not immerse attached plugs in the pumped fluid.
- Only remove the outer packaging at the place of utilisation to ensure that the pump is not damaged during transport.
- Use tear-proof plastic sacks of sufficient size to package the used pump for transport in a leak-proof manner.

3.3 Storage



DANGER

Danger due to fluids which are hazardous to health!

Danger of bacterial infection!

- Disinfect the pump after removal!
- Observe the specifications of the work regulations!



WARNING

Risk of injury from sharp edges!

Sharp edges can form on the impeller and suction port. There is a danger of cuts and similar injuries!

- Wear protective gloves!

CAUTION

Total damage due to moisture ingress

The ingress of moisture into the connection cable damages the cable and the pump! Never immerse the ends of the connection cable in fluid. Seal them tightly during storage.

- Place the pump upright (vertical) on a firm bearing surface.
- Secure the pump against falling over and slipping!
- Store the pump for a maximum of one year. Consult the customer service before storing the device for more than one year.
- Storage conditions:

- Maximum: -15 to +60 °C (5 to 140 °F), max. humidity: 90 %, non-condensing.
 - Recommended: 5 to 25 °C (41 to 77 °F), relative humidity: 40 to 50 %.
 - Protect the pump from direct exposure to sunlight. Extreme heat can cause damage!
- Do not store the pump in rooms where welding work is carried out. The resulting gases or radiation can corrode the elastomer parts and coatings.
- Seal the suction and pressure connection tightly.
- Protect the connection cable against kinking and damage. Maintain a constant bend radius!
- Impellers must be turned by 180° at regular intervals (3 – 6 months). This prevents the bearings from jamming and renews the lubrication film on the mechanical seal. **NO-TICE! Wear protective gloves!**

4 Application/use

4.1 Intended use

For pumping in commercial areas of:

- Sewage not containing faeces
- Wastewater (with small amounts of sand and gravel)
- Wastewater, slightly acidic with a pH value > 4.5
- The Rexa UNI submersible pumps ... B/ and Rexa UNI ... K/ are additionally suitable for pumping of:
 - Lake- and seawater
NaCl content (common salt): max. 30 g/l up to 20 °C
 - Swimming pool water, max. chloride content: 400 mg/l
 - Wastewater, slightly acidic with a pH value of > 3.5

Sewage pumping according to (DIN) EN 12050

The pumps meet the requirements of EN 12050-2.

4.2 Improper use



DANGER

Explosion due to pumping of explosive fluids!

Pumping of highly flammable and explosive fluids (gasoline, kerosene, etc.) in pure form is strictly prohibited. There is a risk of fatal injury due to explosion! The pumps are not designed for these fluids.

CAUTION

Use in biogas applications forbidden!

The fluids in biogas applications are highly aggressive. These fluids will destroy the pump. Use with these fluids is strictly forbidden!

- Untreated sewage
 - Sewage containing faeces
 - Drinking water
 - Fluids containing hard components (such as stones, wood, metal, etc.)
 - Fluids containing high quantities of abrasive contents (e.g. sand, gravel).
 - Fluids with floating contents (e.g. polystyrene, wood chips)
- Intended use also includes compliance with this manual. Any other use is regarded as non-compliant with intended use.

5 Product description

5.1 Description

Submersible pump for stationary and portable wet well installation in intermittent operation.

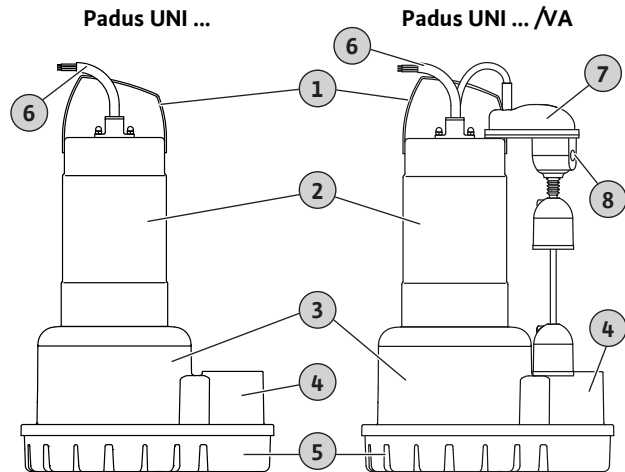

Fig. 2: Overview

1	Handle/attachment point
2	Padus UNI M .../UNI M ... B: Motor housing Padus UNI M ... K: Cooling shroud
3	Hydraulics housing
4	Pressure port
5	Strainer
6	Connection cable
7	Vertical float
8	Vertical float: Manual/automatic switch

Padus UNI M ... /M .../P

Wastewater pump with open multi-channel impeller and vertical threaded connection. Hydraulics housing and impeller made of copolymer. Surface-cooled 1~ motor with integrated operating capacitor and self-switching thermal motor monitoring. Oil-filled sealing chamber with double sealing. Stainless steel motor housing. Detachable connection cable with fitted shockproof plug.

The submersible pumps must **not be used** for pumping:

Padus UNI M ... /M .../A and Padus UNI M ... B/M .../A

Wastewater pump with open multi-channel impeller and vertical threaded connection. Hydraulics housing and impeller made of copolymer. Surface-cooled 1~ motor with integrated operating capacitor and self-switching thermal motor monitoring. Oil-filled sealing chamber with double sealing. Stainless steel motor housing. Detachable connection cable with float switch and fitted shockproof plug.

Padus UNI M ... /M .../VA

Wastewater pump with open multi-channel impeller and vertical threaded connection. Hydraulics housing and impeller made of copolymer. Surface-cooled 1~ motor with integrated operating capacitor and self-switching thermal motor monitoring. Oil-filled sealing chamber with double sealing. Stainless steel motor housing and mounted vertical float switch. Detachable connection cable with fitted shockproof plug.

Padus UNI M ... K/M .../A

Wastewater pump with open multi-channel impeller and vertical threaded connection. Hydraulics housing and impeller made of copolymer. 1~ motor (jacket cooling) with integrated operating capacitor and self-switching thermal motor monitoring. Oil-filled sealing chamber with double sealing. Motor housing and cooling shroud made of stainless steel. Detachable connection cable with float switch and fitted shockproof plug.

Padus UNI M ... /T .../A

Wastewater pump with open multi-channel impeller and vertical threaded connection. Hydraulics housing and impeller made of copolymer. Surface-cooled 3~ motor with thermal motor monitoring. Oil-filled sealing chamber with double sealing. Stainless steel motor housing. Detachable connection cable with CEE plug. Float switch and thermal motor monitoring connected to the CEE plug.

Padus UNI M ... /T ... and Padus UNI M ... B/T ...

Wastewater pump with open multi-channel impeller and vertical threaded connection. Hydraulics housing and impeller made of copolymer. Surface-cooled 3~ motor with thermal motor monitoring. Oil-filled sealing chamber with double sealing. Stainless steel motor housing. Detachable connection cable with bare cable ends.

Padus UNI M ... K/T ...

Wastewater pump with open multi-channel impeller and vertical threaded connection. Hydraulics housing and impeller made of copolymer. 3~ motor (jacket cooling) with thermal motor monitoring. Oil-filled sealing chamber with double sealing. Motor housing and cooling shroud made of stainless steel. Detachable connection cable with bare cable ends.

5.2 Materials

Wilo-Padus UNI	M ...	M ... B/ ...	M ... K/ ...
Hydraulics housing	PP-GF 30	PP-GF 30	PP-GF 30

Wilo-Padus UNI	M ...	M ... B/ ...	M ... K/ ...
Impeller	PP-GF 30	PP-GF 30	PP-GF 30
Motor housing	1.4301 (AISI 304)	1.4401 (AISI 316)	1.4401 (AISI 316)
Cooling shroud	–	–	1.4401 (AISI 316)
Shaft end	1.4401 (AISI 316)	1.4401 (AISI 316)	1.4401 (AISI 316)

Seal

On the pump side	SiC/SiC	SiC/SiC	SiC/SiC
On the motor side	C/Cr	C/Cr	C/Cr
Static	NBR (nitrile)	NBR (nitrile)	NBR (nitrile)

5.3 Technical data**General**

Date of manufacture* [MFY]	See rating plate
Mains connection [U/f]	See rating plate
Power consumption [P ₁]	See rating plate
Rated power [P ₂]	See rating plate
Max. delivery head [H]	See rating plate
Max. volume flow [Q]	See rating plate
Activation type [AT]	See rating plate
Fluid temperature [t]	3 ... 40 °C (37 ... 104 °F)
Fluid temperature, short-term	60 °C (140 °F) for 3 min
Protection class	IP68
Insulation class [Cl.]	F
Speed [n]	See rating plate
Max. switching frequency	60 /h
Permissible immersion depth with attached connection cable [∇]	See rating plate
Immersion depth, max.	20 m (66 ft)
Cable length	10 m (33 ft)

Pressure connection

UNI M05 ...	G 2
-------------	-----

Extended use

Explosion protection	–
Frequency converter operation	–

*The date of manufacture is stated in accordance with ISO 8601:

JJJJWww

→ JJJJ = year

→ W = abbreviation for week

→ ww = calendar week

5.4 Operating modes

	UNI M ...	UNI M ... B/ ...	UNI M ... K/ ...
Immersed [OTs]			
S1	•	•	•
Non-immersed [OTe]			
S1	–	–	•
S2-15 min	•	•	•
S3 10%	•	•	•

Immersed [OTs]

S1	•	•	•
----	---	---	---

Non-immersed [OTe]

S1	–	–	•
S2-15 min	•	•	•
S3 10%	•	•	•

• = permissible, – = not permissible

5.5 Type key

Example: **Wilo-Padus UNI M05B/T15-540/A**

Padus	Submersible drainage pump
UNI	Series
M	Open multi-channel impeller
05	Nominal diameter of pressure connection
B	Version: → None = standard version → B = V4A version → K = version in V4A and with cooling shroud
T	Mains connection version: → M = 1~ → T = 3~
15	/10 = rated power P_2 in kW
5	Mains connection frequency: 5 = 50 Hz, 6 = 60 Hz
40	Rated voltage code
A	Additional electrical equipment: → Without = with bare cable end → P = with plug → A = with float switch and plug → VA = with vertical float switch and plug

5.6 Scope of delivery

Padus UNI M ...

- Pump
- Installation and operating instructions

Padus UNI M ... KIT

- Pump
- Adapter set for 2½" pipe installation:
 - Threaded flange 2" (male thread) to 2½" (female thread)
For screwing into the pressure port. Connection dimension pressure port: +46 mm.
 - Rubber grommet for 2½" pipe

Inside diameter: 75 mm, with 2x pipe clamps.

- Installation and operating instructions

5.7 Accessories

- Connection cables with cable lengths up to max. 50 m (164 ft)
- Suspension unit
- Level control devices
- Fixation accessories and chains
- Switchgear, relays and plugs

6 Installation and electrical connection

6.1 Personnel qualifications

- Electrical work: qualified electrician
Person with appropriate technical training, knowledge and experience who can identify and prevent electrical hazards.
- Installation/dismantling work: trained sewage technology professional
Fixation and pipework in wet well and dry well installation, lifting equipment, basic knowledge of wastewater facilities

6.2 Installation types

- Vertical stationary wet well installation, mounted directly on the pressure pipe
- Vertical portable wet well installation

6.3 Operator responsibilities

- Observe locally applicable accident prevention and safety regulations.
- Observe all regulations for working with heavy loads and under suspended loads.
- Provide protective equipment. Ensure that the protective equipment is worn by personnel.
- Observe the local regulations on the latest technology for the disposal of wastewater and sewage.
- Avoid pressure surges!
Pressure surges can occur in long pressure pipes with steep terrain. These pressure surges can lead to the destruction of the pump!
- Ensure the cooling time of the motor depending on the operating conditions and the size of the pump chamber.
- Structural components and foundations must be of sufficient stability in order to allow the device to be fixed in a secure and functional manner. The operator is responsible for the provision and suitability of the structural component/foundation!
- Check that the available consulting documents (installation plans, installation location, inflow conditions) are complete and accurate.

6.4 Installation



DANGER

Risk of fatal injury due to dangerous lone working practices!

Work in chambers and narrow rooms as well as work involving risk of falling are dangerous work. Such work may not be carried out autonomously!

- Only carry out work with another person!

- Wear protective equipment! Observe the work regulations.
 - Protective gloves: 4X42C (uvex C500)
 - Safety shoes: Protection class S1 (uvex 1 sport S1)
 - Safety helmet: EN 397 Conforms to standards, protection against lateral deformation (uvex pheos) (When using lifting equipment)
- Prepare the installation site:
 - Clean, free of coarse solids
 - Dry
 - Frost-free
 - Disinfected
- Toxic or asphyxiating gases may build up during work:
 - Observe protective measures in accordance with work regulations (gas measurement, carry a gas detector with you).
 - Ensure adequate ventilation.
 - If toxic or asphyxiating gases accumulate, leave the workplace immediately!
- Always carry the pump by the handle!
- Install lifting equipment: even surface, clean, firm base. Warehouse and installation location must be easily accessible.
- Attach chain or wire rope to handle/attachment point with a shackle. Only use lifting gear that has been technically approved.
- All connection cables must be laid properly. The connection cables must not pose any risk (i.e. tripping, damage during operation). Check whether the cable cross-section and the cable length are sufficient for the selected installation type.
- Installation of switchgear: Observe information in the manufacturer's instructions (IP class, overflow-proof, potentially explosive atmospheres)!
- Avoid air intake into the fluid. Use baffles or deflector plates at the inlet. Install the ventilation systems!
- Do not allow the pump to run dry! Avoid air pockets. Do not go below the minimum water level. Installation of dry-running protection is recommended!

6.4.1 Maintenance tasks

After a storage period of more than 12 months, carry out the following maintenance tasks before installation:

- Check the oil in the sealing chamber and replace it if necessary. See section "Oil change in sealing chamber [▶ 39]".

6.4.2 Portable wet well installation

For safe positioning, the pump is equipped with a strainer. This means that the pump can be positioned anywhere at the place of use. The strainer filters coarse solids out of the fluid. A pressure hose is connected on the pressure side.

Use a hard surface or underlay at the place of use to prevent sinking on a soft bearing surface.

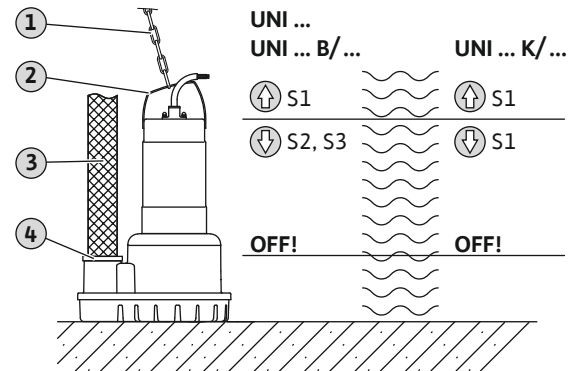

Fig. 3: Wet well installation, portable

1	Lifting equipment
2	Handle/attachment point
3	Pressure hose
4	Hose connection: <ul style="list-style-type: none"> → Hose nozzle with threaded connection and hose clip → Storz pipe coupling
S...	Operating mode at the respective water level
OFF	Min. water level. Switch off the pump.

- ✓ Place of use prepared.
 - ✓ Pressure connection prepared: Hose connection or Storz coupling fitted.
 - ✓ Soft bearing surface: solid surface available.
 - ✓ The pump can be secured against moving away and falling over.
 1. If lifting equipment is used: Use a shackle to attach the lifting equipment to the attachment point on the pump.
 2. Lift and align the pump at the installation location.
 3. Place the pump on a firm bearing surface. Avoid sinking!
 4. Lay the pressure hose and fasten it properly at the appropriate place (e.g. drainage).
 5. Correctly route the connection cables. **CAUTION! Do not damage the connection cables!**
 - No chafing or kinking.
 - Do not immerse the cable end in the fluid.
 - Observe the bending radii.
- ▶ Pump installed, make the electrical connection.

6.4.3 Stationary wet well installation

The pump is installed in a pump chamber or basin. For this purpose, the pump is connected directly to the pressure pipe. The pressure pipe must meet the following requirements:

- The connected pressure pipe is self-supporting. The pressure pipe must **not** be supported by the pump!
 - The pump may vibrate slightly during operation. The pressure pipe must dissipate these vibrations into the foundation.
 - The pressure pipe must not be smaller than the pump's discharge connection.
 - Connect the pressure pipe without tension.
 - All prescribed valves (gate valves, backflow preventers ...) are present.
 - Pressure pipe laid frost-proof.
 - Ventilation systems (e.g. air vent valves) installed. Air pockets in the pump and in the pressure pipe can lead to delivery problems.
- ✓ Place of use prepared.
 - ✓ Installation material (discharge pipe, flexible hose piece, 2x hose clips) available.
 - ✓ Coupling connection mounted on the pump.
1. Shorten the discharge pipe to the required length.
 2. Twist the discharge pipe into the pressure port of the pump as far as it will go.
 3. Slide the hose piece and hose clips over the discharge pipe.
 4. Position the pump under the pressure pipe.
 5. Align the hose piece centrally over the pressure pipe and the discharge pipe.
 6. Fix the hose piece with the hose clips. Observe the max. tightening torque according to the manufacturer's instructions!
 7. Secure the connection cable to the pressure pipe and route it to the socket.

- ▶ Pump installed, make the electrical connection.

6.4.4 Level control

The "A" and "VA" versions are equipped with a float switch. The pump is switched on and off depending on the fill level. The switching level is defined as follows:

- A-version: by the cable length
- VA-version: by the position of the floaters on the guide pin

Observe the following points during installation:

- Float switch must be able to move freely!
 - The minimum permissible water level is **not fallen short of!**
 - The maximum switching frequency is **not exceeded!**
- In order to achieve larger switching differences in case of strongly fluctuating fill levels, provide a level control with two measuring points.

VA-version: Set switching points

The floaters are set to the maximum switching volume at the factory. The floater setting can be changed if required.

- ✓ Pump is out of operation.
 - ✓ Pump disconnected from mains.
1. Undo interior hexagonal head screw on floater.
 2. Set the required switching point: Push the floater upwards or downwards.
 3. Fixing the floater: Tighten interior hexagonal head screw on floater.
- ▶ New switching points are set.

Limited operation due to lack of cooling

- The top floater is set to the upper switching point.
- If the switching point of the upper floater is reset downwards, the pump will **no longer be completely** submerged in the fluid.
- This means that the motor is **no longer completely** cooled!
- The pump may only be operated in operating mode S3 when **immersed or non-immersed!**

6.4.5 Dry-running protection

Dry-running protection prevents the pump from being operated without fluid and air from entering the hydraulics. For this purpose, the minimum permissible fill level is monitored using an external control. When the minimum fill level is reached, the pump is switched off. Furthermore, depending on the control, a visual and acoustic alarm is triggered.

The dry-running protection can be integrated into existing controls as an additional measuring point. Alternatively, the dry-running protection can also work as a stand-alone shut-off device. Depending on the system security, the pump can be restarted automatically or manually.

Installation of dry-running protection is recommended for optimum operational reliability.

6.5 Electrical connection



DANGER

Risk of fatal injury due to electrical current!

Improper conduct when carrying out electrical work can lead to death due to electric shock!

- Electrical work must be carried out by a qualified electrician!
- Observe local regulations!

- Mains connection corresponds to the information on the rating plate.
- Power supply on mains side with clockwise rotating field for three-phase AC motors (3~ motor).
- Route the connection cables according to the local regulations and connect them according to the wire assignment.

- Connect **all** of the monitoring devices and check their function.
- Secure the earthing in accordance with the local regulations.

6.5.1 Fuse on mains side

Circuit breaker

The size and switching characteristics of the circuit breakers must conform to the rated current of the connected product. Observe local regulations.

Motor protection switch

Make provision for an on-site motor protection switch for devices without a plug! The minimum requirement is a thermal relay/motor protection switch with temperature compensation, differential triggering and anti-reactivation device in accordance with the local regulations. In case of sensitive mains, make provision for the installation on-site of other protective equipment (e.g. over-voltage, undervoltage or phase failure relay, etc.).

Residual-current device (RCD)

- Install a residual-current device (RCD) in accordance with the regulations of the local energy supply company.
- If people can come into contact with the device and conductive fluids, install a residual-current device (RCD).

6.5.2 Maintenance tasks

- Check the insulation resistance of the motor winding.
- Check the resistance of the temperature sensors.

6.5.2.1 Checking the insulation resistance of the motor winding

- ✓ Insulation tester 1000 V
- ✓ Motors with **built-in capacitor**: Short-circuited windings!
 1. Check the insulation resistance.
 - ⇒ Measured value at initial commissioning: $\geq 20 \text{ M}\Omega$.
 - ⇒ Measured value at interval measurement: $\geq 2 \text{ M}\Omega$.
 - ▶ Insulation resistance checked. If the measured values deviate from the specifications, consult the customer service.

6.5.2.2 Test the resistor of the temperature sensor

- ✓ Ohmmeter available.
 1. Measure the resistance.
 - ⇒ Measured value **Bimetallic strip**: 0 ohms (passage).
 - ▶ Resistance checked. If the measured value deviates from the specification, consult the customer service.

6.5.3 Connection of the single-phase AC motor (1~ motor)

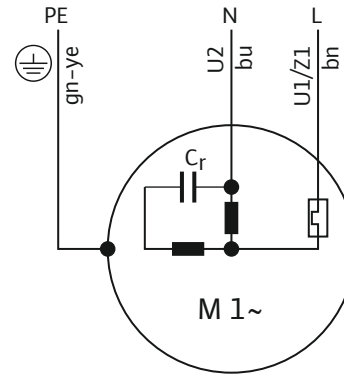

Fig. 4: Connection diagram 1~ motor

Wire colour	Terminal
Brown (bn)	L
Blue (bu)	N
Green/yellow (gn-ye)	Earth

The pump is equipped with a shockproof plug. The connection to the mains is established by inserting the plug into the socket. The plug is not watertight.

Bimetallic strips are installed in the motor for thermal motor monitoring. The motor monitoring is self-switching. Separate connection is not possible.

If the pump is directly connected to the switchgear, cut off the plug. Connect the connection cable according to the connection diagram in the switchgear.

6.5.4 Connection of the three-phase AC motor (3~ motor)

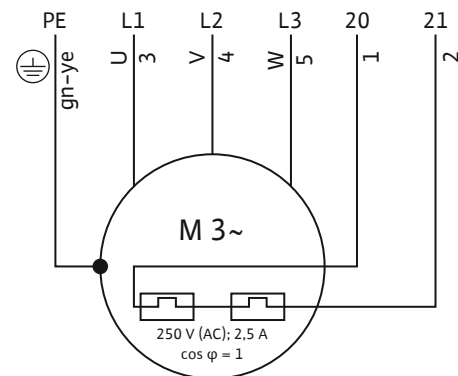

Fig. 5: Connection diagram 3~ motor

Wire number	Name	Terminal
1	20	WSK
2	21	WSK
3	U	L1
4	V	L2
5	W	L3
Green/yellow (gn-ye)	Earth	PE

Pump with plug

The pump is equipped with a CEE motor protection plug. The connection to the mains is established by inserting the plug into the socket. The plug is not watertight.

The thermal motor monitoring (bimetallic strip) is connected in the motor protection plug. When the max. winding temperature is reached, the pump is deactivated. Reactivation must be done manually. Separate connection of the motor monitoring is not necessary.

If the pump is directly connected to the switchgear, disconnect the plug. Connect the connection cable according to the connection diagram in the switchgear.

Pump with bare cable end

- Connection cable with bare cable ends.
- Connection in the switchgear according to the connection diagram.
- Thermal motor monitoring:
 - Bimetallic strip
 - Connection values: max. 250 V(AC), 2.5 A, $\cos \phi = 1$
 - Triggering status: When the max. winding temperature is reached, switch off the pump!

6.5.5 Motor protection adjustment

6.5.5.1 Direct activation

→ Full load

Set the motor protection to the rated current according to the rating plate.

→ Partial load operation

Set the motor protection to 5 % above the current measured at the duty point.

6.5.6 Operation with frequency converter

Operation on the frequency converter is not permitted.

7 Commissioning



NOTICE

Automatic activation after power cut

Depending on the process, the product is switched on and off using separate controls. The product may automatically switch on following power cuts.

7.1 Personnel qualifications

- Operation/control: Operating personnel, instructed in the functioning of the complete system

7.2 Operator responsibilities

- Providing installation and operating instructions by the pump or at a place specially reserved for it.
- Making the installation and operating instructions available in the language of the personnel.

- Making sure that the installation and operating instructions are read and understood by all personnel.
- All safety devices and emergency cut-outs on the system-side must be active and checked to ensure that they work properly.
- The pump is suitable for use under the specified operating conditions.

7.3 Direction of rotation check for three-phase AC motor

The pump has been checked and adjusted to the correct direction of rotation at the factory. To allow the correct direction of rotation, a clockwise rotating field must be available at the mains connection. The pump is **not** approved for operation with a counter-clockwise rotating field!

→ Check the direction of rotation.

Check the rotating field at the mains connection with a rotating-field testing device.

→ Correct the direction of rotation.

Switch two phases.

7.4 Before switching on

Check the following prior to activation:

- Has the electrical connection been carried out in accordance with regulations?
- Has the connection cable been routed safely?
- Can the float switch move freely?
- Accessories attached correctly?
- Temperature of the pumped fluid observed?
- Immersion depth observed?
- Are the pressure pipe and pump sump free of deposits?
- All gate valves in the pressure pipe open?
- Are ventilation systems present in the pressure pipe?
Air pockets in the pump and in the pressure pipe can lead to delivery problems.

7.5 Switching on and off

- When the pump starts, the rated current is exceeded for a short time.
- During operation, do not exceed the rated current any more.

CAUTION! Material damage! If the pump does not start, switch off the pump immediately. Motor failure! Remove the fault first before reactivation.

Observe the following points for transportable installation:

- Place the pump on a firm bearing surface. Avoid sinking!
- If the pump has fallen over, place it upright again before activating it.
- If the pump “moves away”, screw the pump to the ground.

Pump with attached float switch and plug

→ Single-phase AC version (1~ motor)

Insert the plug into the socket, the pump is ready for operation. The pump switches on and off automatically depending on the fill level.

→ Three-phase AC version (3~ motor):

Insert the plug into the socket, the pump is ready for operation. The pump is controlled via two switches on the plug:

- HAND/AUTO: Set the operating mode.
HAND: Switch the pump on and off manually. AUTO: Switch the pump on and off automatically depending on the fill level.
- ON/OFF: Switch the pump on and off in operating mode “HAND”.

Pump with vertical float switch

After inserting the plug into the socket, the pump is ready for operation. The pump is switched on/off depending on the selected operating mode of the float switch:

- “AUTO” operating mode: The pump switches on and off depending on the fill level.
- “MANUEL” operating mode: The pump switches on immediately after the plug has been inserted into the socket.

NOTICE! Set the operating mode at the switch. The switch is located above the upper float switch.

Pump with attached plug

- Single-phase AC version (1~ motor):
Insert the plug into the socket, the pump is switched on.
- Three-phase AC version (3~ motor):
Insert the plug into the socket, the pump is ready for operation. Switch the pump on and off with the ON/OFF switch.

Pumps with bare cable end

The pump is switched on and off using a separate operating point (on/off switch, switchgear) provided by the customer.

7.6 During operation



WARNING

Risk of injury from rotating components!

No persons are allowed to be present in the working area of the pump. There is a risk of injury!

- Demarcate and cordon off the working area.
- If there are no persons in the working area, activate the pump.
- If persons enter the working area, switch off the pump immediately.



WARNING

Risk of burns from hot surfaces!

Motor housing can become hot during operation. It may cause burns.

- Allow the pump to cool down at ambient temperature after switching it off!

CAUTION

Do not allow the pump to dry run!

Dry running of the pump is prohibited. When the minimum delivery level is reached, switch off the pump. Dry running may destroy the seal and cause the pump to be irreparably damaged.



NOTICE

Pumping problems due to water level being too low

The hydraulics are self-venting. Smaller air cushions are resorbed during pumping. If the fluid is lowered too much, separation of the volume flow may occur. The minimum permissible water level must reach the upper edge of the hydraulics housing!

Please regularly check the following points:

- Inlet quantity corresponds to the pump delivery rate.
- The level control device and dry-running protection work correctly.
- Minimum water submersion ensured.
- Connection cable is not damaged.
- Pump free from deposits and encrustations.
- No air intake in the pumped fluid.
- All gate valves open.
- Quiet and low-vibration running.
- Max. switching frequency not exceeded.
- Mains connection tolerances:
 - Operating voltage: +/-10 %
 - Frequency: +/- 2 %
 - Current consumption between the individual phases: max. 5 %
 - Voltage difference between the individual phases: max. 1 %



NOTICE

Emerge the motor during operation

- If the motor is emerged during operation, observe the “operating mode non-immersed”! See indication “OT_E” on the rating plate!
- Ensure cooling of the motor for continuous duty: The motor must be completely immersed before reactivation!

Operating mode S3 10 %: Operating mode S3 25 % is permitted if the necessary motor cooling is ensured before reactivation! To ensure the required cooling, the motor must be completely immersed for at least 1 min!

8 Shut-down/dismantling

8.1 Personnel qualifications

- Operation/control: Operating personnel, instructed in the functioning of the complete system
- Electrical work: qualified electrician
Person with appropriate technical training, knowledge and experience who can identify and prevent electrical hazards.
- Installation/dismantling work: trained sewage technology professional
Fixation and pipework in wet well and dry well installation, lifting equipment, basic knowledge of wastewater facilities

8.2 Operator responsibilities

- Locally applicable accident prevention and safety regulations of trade associations.
- Observe regulations for working with heavy loads and under suspended loads.
- Provide the necessary protective equipment and make sure that the personnel wears it.
- Provide adequate aeration in closed rooms.
- Take immediate countermeasures if there is a build-up of toxic or suffocating gases!

8.3 Shut-down

The pump is deactivated, but remains installed. This ensures that the pump is always ready for operation.

- ✓ Completely immerse the pump in the fluid to protect the pump from frost and ice.
- ✓ Minimum fluid temperature: +3 °C (+37 °F).
 1. Switch off the pump.
 2. Secure the operating point against being switched on again by unauthorised persons (e.g. lock main switch).
 - ▶ The pump is decommissioned.

If the pump remains installed after decommissioning, observe the following points:

- Ensure that the aforementioned requirements are maintained for the complete period of shutdown. Remove the pump if meeting these requirements cannot be guaranteed!
- For an extended period of shutdown, carry out a function test at regular intervals:
 - Period: monthly to quarterly
 - Running time: 5 minutes
 - Only run a function test in valid operating conditions!

8.4 Removal



DANGER

Danger due to fluids which are hazardous to health!

Danger of bacterial infection!

- Disinfect the pump after removal!
- Observe the specifications of the work regulations!



DANGER

Risk of fatal injury due to electrical current!

Improper conduct when carrying out electrical work can lead to death due to electric shock!

- Electrical work must be carried out by a qualified electrician!
- Observe local regulations!



DANGER

Risk of fatal injury due to dangerous lone working practices!

Work in chambers and narrow rooms as well as work involving risk of falling are dangerous work. Such work may not be carried out autonomously!

- Only carry out work with another person!



WARNING

Risk of burns from hot surfaces!

Motor housing can become hot during operation. It may cause burns.

- Allow the pump to cool down at ambient temperature after switching it off!

Wear the following protective equipment while performing the work:

- Safety shoes: Protection class S1 (uvex 1 sport S1)
- Protective gloves: 4X42C (uvex C500)
- Safety helmet: EN 397 Conforms to standards, protection against lateral deformation (uvex pheos)
(When using lifting equipment)

If contact with hazardous fluid occurs during work, wear the following additional protective equipment:

- Safety goggles: uvex skyguard NT
 - Labelling frame: W 166 34 F CE
 - Labelling disc: 0-0.0* W1 FKN CE
- Breathing protection: Half mask 3M series 6000 with filter 6055 A2

The protective equipment specified is the minimum requirement. Observe the specifications of the work regulations!

* Protection level according to EN 170 not relevant for this work.

8.4.1 Stationary wet well installation

- ✓ Pump is decommissioned.
- ✓ Gate valves on the inlet and pressure sides are closed.
 1. Disconnect the pump from the mains.
 2. Disconnect the connection cable from the pressure pipe.
 3. Release the pump and discharge pipe from the pressure pipe.
 4. Lift the pump by the handle out of the operating space.
 5. Unscrew the discharge pipe from the pressure port.
 6. Coil up the connection cables and attach them to the motor.
 - Do not kink.
 - Do not crush.
 - Observe the bending radii.
 7. Thoroughly clean the pump and discharge pipe (see section "Cleaning and disinfecting").

8.4.2 Portable wet well installation

- ✓ Pump has been decommissioned.
 1. Disconnect the pump from the mains.
 2. Coil up the connection cables and attach them to the motor.
 - Do not kink.
 - Do not crush.
 - Observe the bending radii.
 3. Loosen the pressure pipe from the pressure port.
 4. Attach the lifting equipment to the attachment point.
 5. Lift the pump out of the operating space. **CAUTION! Do not damage the connection cable! Pay attention to the connection cable when setting down the pump!**
 6. Thoroughly clean the pump (see section "Cleaning and disinfecting").

8.4.3 Clean and disinfect

- Wear protective equipment! Observe the work regulations.
 - Safety shoes: Protection class S1 (uvex 1 sport S1)
 - Breathing protection: Half mask 3M series 6000 with filter 6055 A2
 - Protective gloves: 4X42C + Type A (uvex protector chemical NK2725B)
 - Safety goggles: uvex skyguard NT
- Use of disinfectants:
 - Use strictly according to the manufacturer's instructions!
 - Wear protective equipment according to the manufacturer's instructions!
- Dispose of rinsing water in accordance with the local regulations, e.g. feed it into the sewer!
 - ✓ Pump removed.

1. Ensure that the plug or bare cable ends are packed and stored in a watertight manner!
2. Attach the lifting equipment to the attachment point on the pump.
3. Lift the pump approximately 30 cm (10 in) above the ground.
4. Spray the pump with clean water from top to bottom.
5. Direct the water jet towards the inside via the pressure port to clean the impeller and the pump interior.
6. Disinfect the pump.
7. Dispose of dirt residue on the ground, e.g. flush it into the sewer.
8. Let the pump dry out.

In order to completely drain the pump housing, put the pump down on its side for approx. 5 minutes. Place the pressure port face down.

8.4.3.1 Cleaning the strainer

The strainer can be removed for cleaning.



WARNING

Risk of injury from sharp edges!

Sharp edges can form on the impeller and suction port. There is a danger of cuts and similar injuries!

- Wear protective gloves!

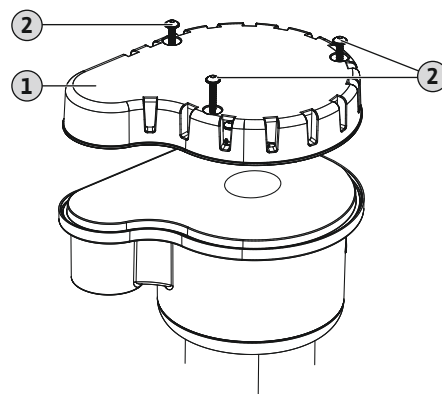

Fig. 6: Remove the baseplate

1	Strainer
2	Fastening screws, size 4 Allen key

1. Place the pump on a firm work surface in a horizontal position.
2. Secure the pump against falling over and slipping!
3. Remove the fastening screws at the strainer.
4. Remove the strainer.

5. Rinse the strainer and baseplate of the hydraulics with clear water and remove solids manually.
6. Position the strainer.
7. Screw in the fastening screws. **Max. tightening torque: 5.5 Nm (4 ft-lb)!**
 - ▶ Strainer cleaned and fitted. Complete the cleaning work.

9 Maintenance and repair

9.1 Personnel qualifications

- Electrical work: qualified electrician
Person with appropriate technical training, knowledge and experience who can identify and prevent electrical hazards.
- Maintenance work: trained sewage technology professional
Application/disposal of operating fluids used, basic engineering knowledge (installation/dismantling)

9.2 Operator responsibilities

- Provide the necessary protective equipment and make sure that the personnel wears it.
- Collect operating fluids in suitable tanks and dispose of properly.
- Dispose of protective clothing used in accordance with regulations.
- Use only original parts of the manufacturer. The use of any non-original parts releases the manufacturer from any liability.
- Collect any leakage of fluid and operating fluid immediately and dispose of it according to the locally applicable guidelines.
- Provide the tools required.
- If flammable solvents and cleaning agents are used, fire, naked flames and smoking are prohibited.
- Document maintenance tasks in the system's inspection list.

9.3 Operating fluid

9.3.1 Oil types

- ExxonMobile: Marcol 52
- ExxonMobile: Marcol 82
- Total: Finavestan A 80 B (NSF-H1 certified)

9.3.2 Filling quantities

The filling quantity is 1200 ml (40 US.fl.oz).

9.4 Maintenance intervals

- Regularly carry out maintenance tasks.
- Contractually adjust maintenance intervals depending on the actual environmental conditions. Contact customer service.
- If strong vibrations occur during operation, check the installation.

9.4.1 Maintenance intervals for normal conditions

1500 operating hours or after 5 years

- Visual inspection of the connection cables
- Visual inspection of accessories

- Visual inspection of the coating and housing
- Function test of monitoring devices
- Sealing chamber oil change
- Adjusting the impeller clearance

5000 operating hours or after 10 years

- Complete overhaul

9.4.2 Maintenance intervals for harsh conditions

Under the following operating conditions, shorten the specified maintenance intervals in consultation with the customer service:

- Fluids with long-fibre components
- Turbulent inlet (e.g. due to air entry, cavitation)
- Highly corrosive or abrasive fluids
- Strongly gassing fluids
- Operation at an unfavourable duty point
- Pressure surges

If there are harsh operating conditions, it is recommended to conclude a maintenance contract.

9.5 Maintenance measures



WARNING

Risk of injury from sharp edges!

Sharp edges can form on the impeller and suction port. There is a danger of cuts and similar injuries!

- Wear protective gloves!

Before starting maintenance work, meet the following requirements:

- Wear protective equipment! Observe the work regulations.
 - Safety shoes: Protection class S1 (uvex 1 sport S1)
 - Protective gloves: 4X42C (uvex C500)
 - Safety goggles: uvex skyguard NT
- For detailed marking of frame and disc, see the section on "Personal protective equipment [▶ 25]".
- The pump has been thoroughly cleaned and disinfected.
- Motor must have cooled down to the ambient temperature.
- Workplace:
 - Clean, good lighting and ventilation.
 - Firm and stable work surface.
 - Secured against falling over and slipping.

NOTICE! Only perform the maintenance work described in these installation and operating instructions.

9.5.1 Visual inspection of the connection cable

Check connection cable for:

- Bubbles
- Cracks
- Scratches
- Abrasion
- Pinch points

If the connection cable is damaged:

- Decommission the pump immediately!
- Have the connection cable replaced by the customer service!

CAUTION! Material damage! Damaged connection cables cause water to enter the motor. Water in the motor leads to total damage of the pump.

9.5.2 Visual inspection of accessories

Accessories must be checked for:

- Correct fixation
- Smooth function
- Signs of wear, e.g. cracks caused by frequencies

Any defects detected must be repaired immediately or the accessories must be replaced.

9.5.3 Visual inspection of the coatings and housings

Coatings and housings must not show any damage. If there are defects, observe the following:

- Repair damaged coating. Order repair kits from the customer service.
- If housings are worn out, consult the customer service!

9.5.4 Function test of the monitoring device

To test resistances, the pump must be cooled down to the ambient temperature!

9.5.4.1 Test the resistor of the temperature sensor

- ✓ Ohmmeter available.
- 1. Measure the resistance.
 - ⇒ Measured value **Bimetallic strip**: 0 ohms (passage).
- ▶ Resistance checked. If the measured value deviates from the specification, consult the customer service.

9.5.5 Oil change in sealing chamber



WARNING

Operating fluid under pressure!

High pressure can build up in the motor! This pressure is released when the screw plugs are **opened**.

- If screw plugs are opened without due caution, they can be ejected at high speed!
- Hot operating fluid may spray out!

- ⇒ **Wear protective equipment!**
- ⇒ **Allow the motor to cool down to ambient temperature before carrying out any work!**
- ⇒ **Adhere to the prescribed sequence of work steps!**
- ⇒ **Unscrew the screw plugs slowly.**
- ⇒ **As soon as the pressure escapes (audible whistling or hissing of air), stop turning the screw plug any further!**
- ⇒ **Only when the pressure has been completely released, fully unscrew the screw plug.**

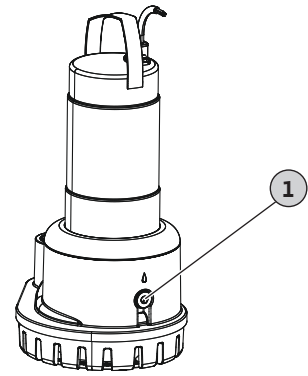

Fig. 7: Sealing chamber: Oil change

1 Sealing chamber screw plug

- ✓ Protective equipment used!
- ✓ Pump has been removed, cleaned and disinfected.
- 1. Place the pump on a firm work surface in a horizontal position. The screw plug should face upwards.
- 2. Secure the pump against falling over and slipping!
- 3. Unscrew the screw plug slowly.
- 4. When the pressure has been released, completely unscrew the screw plug.
- 5. Position a suitable tank to collect the operating fluid.
- 6. Drain the operating fluid: Rotate the pump until the opening points downwards.
- 7. Check the operating fluid:
 - ⇒ Operating fluid clear: Operating fluid can be reused.
 - ⇒ Operating fluid contaminated (black): fill with new operating fluid.
 - ⇒ Operating fluid milky/cloudy: Water in oil. Minor leakage through the mechanical seal is normal. If the ratio of oil to water is less than 2:1, the mechanical seal may be damaged. Change the oil and check again four weeks later. If water is again present in the oil during the second check, contact customer service!
 - ⇒ Metal chips in the operating fluid: Contact the customer service!
- 8. Pour in operating fluid: Rotate the pump until the opening points upwards. Pour the operating fluid into the opening.
 - ⇒ Comply with the specifications for the operating fluid type and quantity!
- 9. Clean the screw plug, replace the seal ring and screw it back in. **Max. tightening torque: 8 Nm (5.9 ft·lb)!**

9.5.6 Adjusting the impeller clearance

When pumping wastewater and sewage, wear can occur at the impeller. This lowers the pump's output. The clearance between

the impeller and suction port can be adjusted to compensate for impeller wear.

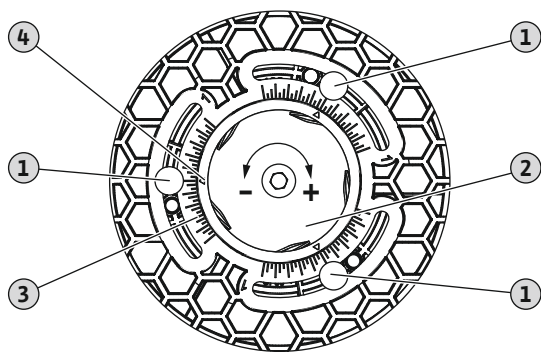

Fig. 8: Adjusting the impeller clearance (strainer removed)

1	Safety screws for fixing the clearance adjustment
2	Clearance adjustment
3	Dial
4	Pointer (▲)
+	Increase clearance
-	Decrease clearance

- ✓ Strainer removed. See “Cleaning the strainer [► 37]”
 - ✓ Baseplate cleaned. The dial and pointer are discernible.
1. Loosen the safety screws until the clearance adjustment can be turned. **NOTICE! Do not completely unscrew the screws!**
 2. Turn the clearance adjustment anti-clockwise (-) until the counterplate rests against the impeller.
 3. Increase the clearance by 3 division marks: Turn the clearance adjustment clockwise (+). Observe the pointer when setting!
 4. Tighten the safety screws. **Max. tightening torque: 4 Nm (3 ft·lb)!**
 - Impeller clearance corrected. Refit the strainer.

9.5.7 General overhaul

During the general overhaul, the motor bearings, shaft sealings, O-rings and connection cables are checked for wear and damage. Damaged components are replaced with original parts. This ensures correct operation.

The general overhaul is performed by the manufacturer or an authorised service centre.

10 Faults, causes and remedies



WARNING

Risk of injury from rotating components!

No persons are allowed to be present in the working area of the pump. There is a risk of injury!

- Demarcate and cordon off the working area.
- If there are no persons in the working area, activate the pump.
- If persons enter the working area, switch off the pump immediately.

Fault: Pump does not start

1. Electricity supply interrupted or short-circuit/earth fault in the cable or motor winding.
 - ⇒ Have the connection and motor checked by a qualified electrician and replace if necessary.
2. Tripping of fuses, of the motor protection switch or the monitoring equipment
 - ⇒ Have the connection and the monitoring equipment checked by a qualified electrician and change it if necessary.
 - ⇒ Have the motor protection switches and fuses installed and adjusted according to the technical specifications by a qualified electrician and reset monitoring equipment.
 - ⇒ Check the impeller to make sure that it runs smoothly, clean the hydraulics if necessary.

Fault: Pump starts up, motor protection trips after short period

1. Motor protection switch set incorrectly.
 - ⇒ Have the adjustment of the trigger checked and corrected by a qualified electrician.
2. Increased power consumption due to major voltage drop.
 - ⇒ Have the voltage of individual phases checked by a qualified electrician. Contact the electricity distribution network.
3. There are only two phases at the connection.
 - ⇒ Have the connection checked and corrected by a qualified electrician.
4. Excessive differences in voltage between the phases.
 - ⇒ Have the voltage of individual phases checked by a qualified electrician. Contact the electricity distribution network.
5. Incorrect direction of rotation.
 - ⇒ Have the connection corrected by a qualified electrician.

6. Increased power consumption through jammed hydraulics.
 - ⇒ Clean the hydraulics and check the inlet.
7. The density of the fluid is too high.
 - ⇒ Contact customer service.

Fault: Pump runs, there is no volume flow

1. There is no fluid.
 - ⇒ Check the inlet, open all gate valves.
2. Inlet clogged.
 - ⇒ Check the inlet and remove clogging.
3. Hydraulics jammed.
 - ⇒ Clean the hydraulics.
4. Pipe system on the pressure side or pressure hose clogged.
 - ⇒ Remove clogging and replace the damaged components if necessary.
5. Intermittent operation.
 - ⇒ Check the switching system.

Fault: Pump starts, duty point is not reached

1. Inlet clogged.
 - ⇒ Check the inlet and remove clogging.
2. Slide valves on the pressure side closed.
 - ⇒ Open all gate valves completely.
3. Hydraulics jammed.
 - ⇒ Clean the hydraulics.
4. Incorrect direction of rotation.
 - ⇒ Have the connection corrected by a qualified electrician.
5. Air cushion in the pipe system.
 - ⇒ Vent the pipe system.
 - ⇒ If air cushions occur frequently: Locate and prevent the air intake, if required install ventilation systems at specified locations.
6. Pump pumping against excessive pressure.
 - ⇒ Open all gate valves on the pressure side completely.
7. Signs of wear on the hydraulics.
 - ⇒ Have the components (impeller, suction port, pump housing) checked and replaced by customer service.
 - ⇒ Impeller clearance too great. Adjust the impeller clearance.
8. Pipe system on the pressure side or pressure hose clogged.
 - ⇒ Remove clogging and replace the damaged components if necessary.
9. Strongly gassing fluid.

⇒ Contact customer service.

10. The connection only has two phases.
 - ⇒ Have the connection checked and corrected by a qualified electrician.
11. Excessive decrease in the fill level during operation.
 - ⇒ Check supply/capacity of the system.
 - ⇒ Have the switching points of the level control checked and adjusted if necessary.

Fault: The pump does not run smoothly and is noisy

1. Improper duty point.
 - ⇒ Check the pump configuration and the duty point, contact customer service.
2. Hydraulics jammed.
 - ⇒ Clean the hydraulics.
3. Strongly gassing fluid.
 - ⇒ Contact customer service.
4. There are only two phases at the connection.
 - ⇒ Have the connection checked and corrected by a qualified electrician.
5. Incorrect direction of rotation.
 - ⇒ Have the connection corrected by a qualified electrician.
6. Signs of wear on the hydraulics.
 - ⇒ Have the components (impeller, suction port, pump housing) checked and replaced by customer service.
7. Motor bearings have worn.
 - ⇒ Inform customer service; send the pump back to the factory for overhauling.
8. Pump is installed under tension.
 - ⇒ Check installation, install rubber compensators if necessary.

Further steps for troubleshooting

If the points listed here do not rectify the fault, contact customer service. Customer service can assist in the following ways:

- Telephone or written support.
- On-site support.
- Inspection and repair at the factory.

Costs may be incurred if you request customer services! Please contact customer services for more information.

11 Spare parts

Spare parts are ordered via customer service. To avoid return queries and incorrect orders, the serial or article number must always be supplied. **Subject to change without prior notice!**

12 Disposal

12.1 Oils and lubricants

Operating fluid must be collected in suitable tanks and disposed of in accordance with the locally applicable guidelines. Wipe up drips immediately!

12.2 Protective clothing

Used protective clothing must be disposed off in accordance with the locally applicable guidelines.

12.3 Information on the collection of used electrical and electronic products

Proper disposal and appropriate recycling of this product prevents damage to the environment and putting your personal health at risk.



NOTICE

Disposal in domestic waste is prohibited!

In the European Union this symbol may be included on the product, the packaging or the accompanying documentation. It means that the electrical and electronic products in question must not be disposed of along with domestic waste.

Please note the following points to ensure proper handling, recycling and disposal of the used products in question:

- Hand over these products at designated, certified collection points only.
- Observe the locally applicable regulations!

Please consult your local municipality, the nearest waste disposal site, or the dealer who sold the product to you for information on proper disposal. See www.wilo-recycling.com for more information about recycling.

Subject to change without prior notice!



wilo

Pioneering for You



Local contact at
www.wilo.com/contact

WILO SE
Nortkirchenstr. 100
44263 Dortmund
Germany
T +49 (0)231 4102-0
T +49 (0)231 4102-7363
wilo@wilo.com
www.wilo.com