

Wilo-Atmos BST

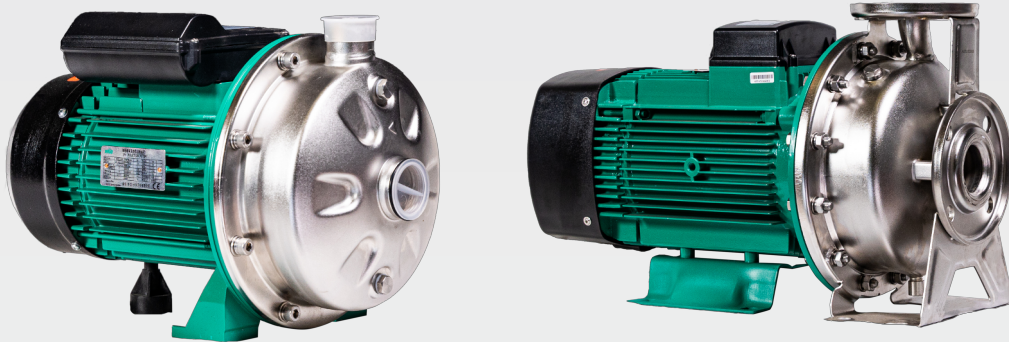

en Installation and operating instructions



Atmos BST 50 Hz
<https://qr.wilo.com/278>



Atmos BST 60 Hz
<https://qr.wilo.com/3278>

Fig. I: Atmos BST-P7 (Design mit Gewindeanschluss)

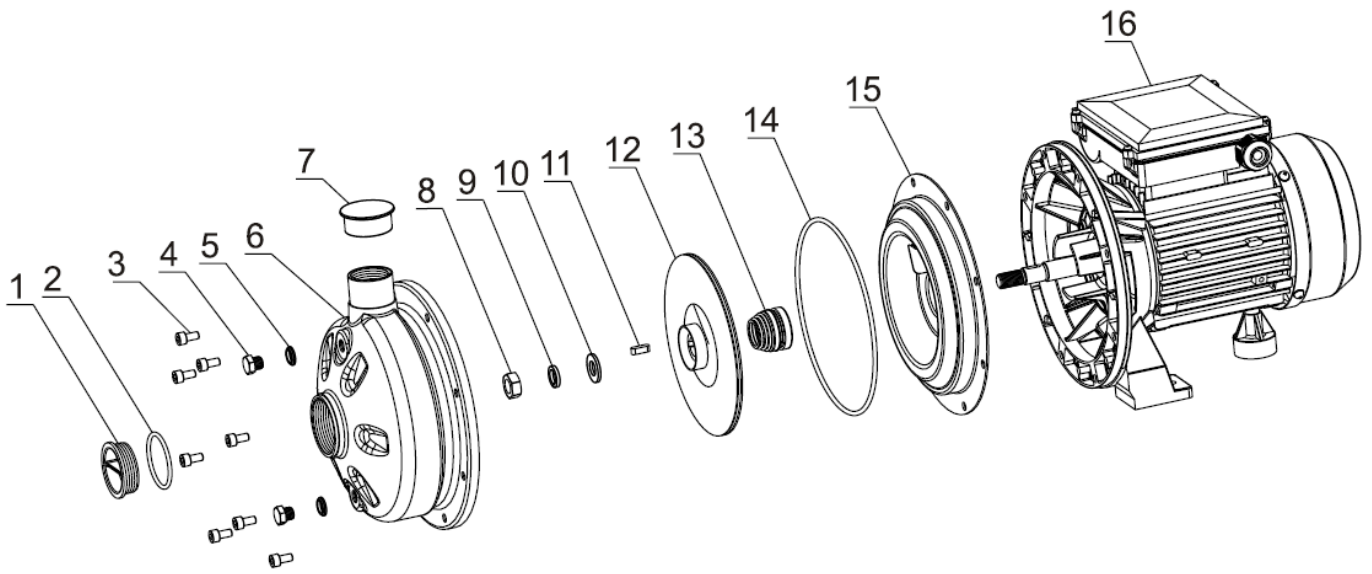

Fig. II: Atmos BST (Design mit Flanschanschluss)

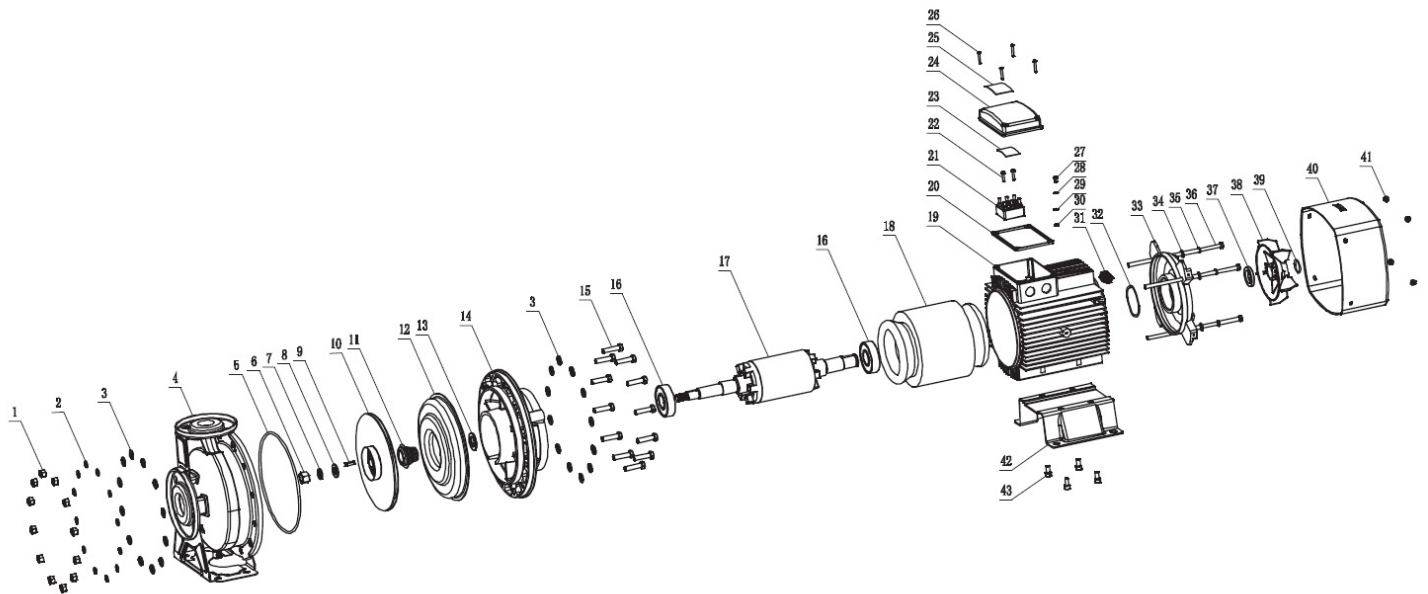

Table of Contents

1	General information	6
1.1	About these instructions	6
1.2	Copyright	6
1.3	Subject to change	6
2	Safety	6
2.1	Identification of safety instructions.....	6
2.2	Personnel qualifications.....	7
2.3	Electrical work	7
2.4	Transport.....	8
2.5	Installing/dismantling.....	8
2.6	During operation	9
2.7	Maintenance work	9
2.8	Operator responsibilities.....	10
3	Transport and storage	10
3.1	Transport inspection	10
3.2	Transport for installation/dismantling purposes.....	11
3.3	Storage	12
4	Intended use and misuse	13
4.1	Intended use	13
4.2	Misuse.....	13
5	Product information	13
5.1	Type key	13
5.2	Technical data	14
5.3	Scope of delivery.....	15
5.4	Accessories	15
6	Description of the pump	15
6.1	Anticipated noise levels	15
7	Installation	15
7.1	Personnel qualifications.....	16
7.2	Operator responsibilities.....	16
7.3	Safety.....	16
7.4	Preparing the installation.....	17
8	Electrical connection	19
9	Commissioning	21
9.1	Filling and venting.....	21
9.2	Activation.....	22
9.3	Switching off	23
9.4	Operation	23
10	Maintenance	24
10.1	Maintenance work	25
11	Faults, causes and remedies	25
12	Spare parts	27
12.1	Recommended stocking of spare parts for two-year continuous operation.....	27
12.2	Spare parts list	28
13	Disposal	28
13.1	Oils and lubricants.....	28
13.2	Information on the collection of used electrical and electronic products.....	28

1 General information

1.1 About these instructions

These instructions are an integral part of the product. Adherence to these instructions is a requirement for the intended use and correct operation of the product:

- Read these instructions before commencing any work and keep them in an accessible place at all times.
- Observe instructions and labelling on the pump.
- Observe local regulations where the pump is installed.
- No liability will be accepted for damage resulting from failure to follow these instructions.

The language of the original operating instructions is German. All other languages of these instructions are translations of the original operating instructions.

1.2 Copyright

WILO SE © 2023

The reproduction, distribution and utilisation of this document in addition to communication of its contents to others without express authorisation is prohibited. Offenders will be held liable for payment of damages. All rights reserved.

1.3 Subject to change

Wilo shall reserve the right to change the listed data without notice and shall not be liable for technical inaccuracies and/or omissions. The illustrations used may differ from the original and are intended as an exemplary representation of the product.

2 Safety

This chapter contains basic instructions for the individual life cycles of the product. Failure to observe this information carries the following risks:

- Danger to persons from electrical, mechanical and bacteriological effects as well as electromagnetic fields
- Environmental damage from discharge of hazardous substances
- Damage to property
- Failure of important product functions
- Failure of required maintenance and repair procedures

Failure to observe the instructions will result in the loss of any claims for damages.

The directions and safety instructions in the other sections must also be observed!

2.1 Identification of safety instructions

These installation and operating instructions set out safety instructions for preventing personal injury and damage to property, which are displayed in different ways:

- Safety instructions relating to personal injury start with a signal word and are **preceded by a corresponding symbol**.
- Safety instructions relating to property damage start with a signal word and are displayed **without** a symbol.

Signal words

- **DANGER!**

Failure to follow the instructions will result in serious injury or death!





- **Warning!**

Failure to follow instructions can lead to (serious) injury!

- **Caution!**
Failure to follow instructions can lead to property damage and possible total loss.
- **Notice!**
Useful information on handling the product

Symbols

These instructions use the following symbols:

-  General danger symbol
-  Danger of electric voltage
-  Warning of hot surfaces
-  Warning of high pressure
-  Notices

2.2 Personnel qualifications

Staff must:

- be instructed about locally applicable regulations governing accident prevention,
- have read and understood the installation and operating instructions.

Personnel must have the following qualifications:

- Electrical work: a qualified electrician must carry out the electrical work.
- Installation/dismantling: The technician must be trained in the use of the necessary tools and fixation materials.
- The product must be operated by persons who have been instructed on how the complete system functions.
- Maintenance work: The technician must be familiar with the use of operating fluids and their disposal.

Definition of “qualified electrician”

A qualified electrician is a person with appropriate technical education, knowledge and experience who can identify **and** prevent electrical hazards.

The operator must confirm and ensure the field of authority, the competence and the monitoring of the personnel. If the personnel do not possess the necessary knowledge, they must be trained and instructed. If required, this can be carried out by the product manufacturer at the operator’s request.

2.3 Electrical work

- Have electrical work carried out by a qualified electrician.
- When connecting to the mains supply, comply with the nationally applicable guidelines, standards and regulations as well as specifications issued by the local energy supply companies.

- Before commencing work, disconnect the product from the mains and secure it against being switched on again.
- Give staff training on how to establish the electrical connection and the methods for switching off the product.
- Protect the electrical connection with a residual-current device (RCD).
- Observe the technical information in these installation and operating instructions as well as on the rating plate.
- Earth the product.
- Comply with the manufacturer's specifications when connecting the product to electrical switching systems.
- Have a defective connection cable replaced immediately by a qualified electrician.
- Never remove operating elements.
- Comply with the specifications on electromagnetic compatibility when using electronic start-up controllers (e.g. soft starter or frequency converter). If required, consider special measures (shielded cables, filters, etc.).

2.4 Transport

- Wear protective equipment:
 - Safety gloves for protection against cuts
 - Safety shoes
 - Sealed safety glasses
 - Safety helmet (when using lifting equipment)
- Only use legally specified and approved lifting slings.
- Select the lifting sling based on the prevailing conditions (weather, slinging point, load etc.).
- Always attach the lifting sling to the designated slinging points (lifting eyes).
- Position the lifting accessory in a way that ensures stability during use.
- When using lifting equipment, a second person must be present to coordinate the procedure if required (e.g. if the operator's field of vision is blocked).
- Persons must not stand underneath suspended loads. Do **not** move suspended loads over workplaces where people are present.

2.5 Installing/dismantling

- Wear protective equipment:
 - Safety shoes
 - Safety gloves for protection against cuts
 - Safety helmet (when using lifting equipment)
- Locally applicable laws and regulations on work safety and accident prevention must be complied with.

- The procedure described in the installation and operating instructions for shutting down the product/unit must be strictly observed.
- Disconnect the device from the mains and secure it against being switched on again without authorisation.
- All rotating parts must be at a standstill.
- Close the gate valve in the inlet and in the discharge line.
- Provide adequate aeration in enclosed spaces.
- Make sure that there is no risk of explosion when carrying out any type of welding work or work with electrical devices.

2.6 During operation

- The operator must immediately notify the person in charge of every fault or irregularity.
- If hazardous defects occur, the operator must immediately deactivate the device. Hazardous defects include:
 - Malfunction of safety and monitoring devices
 - Damage to housing parts
 - Damage to electrical equipment
- Collect any leakage of fluids and operating fluids immediately and dispose of it according to the locally applicable guidelines.
- Tools and other objects should only be kept in their designated places.

2.7 Maintenance work

- Wear protective equipment:
 - Sealed safety glasses
 - Safety shoes
 - Safety gloves for protection against cuts
- Locally applicable laws and regulations on work safety and accident prevention must be complied with.
- The procedure described in the installation and operating instructions for shutting down the product/unit must be strictly observed.
- Only perform the maintenance work described in these installation and operating instructions.
- Only original parts from the manufacturer may be used for maintenance and repairs. The use of any non-original parts releases the manufacturer from any liability.
- Disconnect the device from the mains and secure it against being switched on again without authorisation.
- All rotating parts must be at a standstill.
- Close the gate valve in the inlet and in the discharge line.
- Collect any leakage of fluid and operating fluid immediately and dispose of it according to the locally applicable guidelines.
- Store tools at the designated locations.
- After completing work, reattach all safety and monitoring devices and check that they function properly.

2.8 Operator responsibilities

- Provide installation and operating instructions in a language which the personnel can understand.
- Make sure that personnel are suitably trained for the specified work.
- Verify the area of responsibility and individual responsibilities of personnel.
- Provide the necessary protective equipment and make sure that personnel wear it.
- Ensure that safety and information signs mounted on the device are always legible.
- Train personnel with regard to the operating principles of the system.
- Eliminate risks from electrical current.
- Equip hazardous components (extremely cold, extremely hot, rotating, etc.) with a guard to be provided by the customer.
- Remove leakages of hazardous fluids (e.g. explosive, toxic or hot) in such a way that no danger is posed to persons or the environment. Comply with national statutory provisions.
- Keep highly flammable materials at a safe distance from the product.
- Ensure compliance with the regulations for accident prevention.
- Ensure compliance with local directives or general directives [e.g. IEC, VDE, etc.] and instructions from local energy supply companies.

Follow all information that appears on the product and ensure that it remains permanently legible:

- Warning and hazard notices
- Rating plate
- Direction of rotation arrow/symbol for direction of flow
- Labelling of connections

This device can be used by children from 8 years of age as well as people with reduced physical, sensory or mental capacities or lack of experience and knowledge if they are supervised or instructed on the safe use of the device and they understand the dangers that can occur. Children are not allowed to play with the device. Cleaning and user maintenance must not be carried out by children without supervision.

3 Transport and storage

3.1 Transport inspection

Check delivery immediately for damage and completeness. Defects must be noted on the freight documentation! Defects must be notified to the transport company or the manufacturer immediately on the day of receipt of shipment. Subsequently notified defects can no longer be claimed for.

Only remove the outer packaging at the place of utilisation to ensure that the pump is not damaged during transport.

3.2 Transport for installation/dismantling purposes

Existing regulations for the prevention of accidents must be followed!



WARNING

Risk of injury from a lack of protective equipment!

Danger of (serious) injuries during work. Wear the following protective equipment:

- Safety gloves for protection against cuts
- Safety shoes
- Safety helmet must be worn if lifting accessories are used!



WARNING

Risk of personal injury!

Incorrect transport can lead to personal injury!

- Unload boxes, lathed spaces, pallets or cartons, depending on the size and construction, with forklift trucks or with slings.
- Always lift heavy parts of more than 30 kg with hoisting gear that is in accordance with local regulations.
 - The bearing capacity has to be adapted to the weight!
- Transport the pump using approved lifting gear (block and tackle, crane etc.). Lifting gear must be attached to the pump flanges and, if necessary, to the outer motor diameter.
 - Securing against slipping is required for this!
- When lifting machines or parts with eyelets, only use load hooks or shackles that are in accordance with local safety regulations.
- The transport lugs on the motor are only for transporting the motor. They are not approved for transporting the complete pump.
- If load chains or ropes are put over sharp edges, a guard has to be used or they have to be put through the eyelets.
- When using a block and tackle or similar hoisting gear, make sure that the load is lifted vertically.
- Prevent the suspended load from swinging.
 - Swinging can be avoided by using a second block and tackle. The direction of pull of both block and tackles must be less than 30° to the vertical.
- Never subject load hooks, eyelets or shackles to bending forces – their load axes have to be in the direction of the tractive forces!
- When lifting, make sure that the load limit of a load rope is reduced for diagonal pulling.
 - The safety and effectiveness of a stranding is best ensured when all load-bearing elements are loaded in the vertical direction to the greatest extent possible. If required, use a lifting arm which can be attached vertically to the load rope.
- Set up a safety zone in such a way that there is no danger if the load or a part of the load slips or the hoisting gear breaks or tears.
- Never leave a load longer than necessary in a suspended position! Ensure there is no danger to personnel when accelerating and slowing down during the lifting procedure.

3.2.1 Fitting load slings

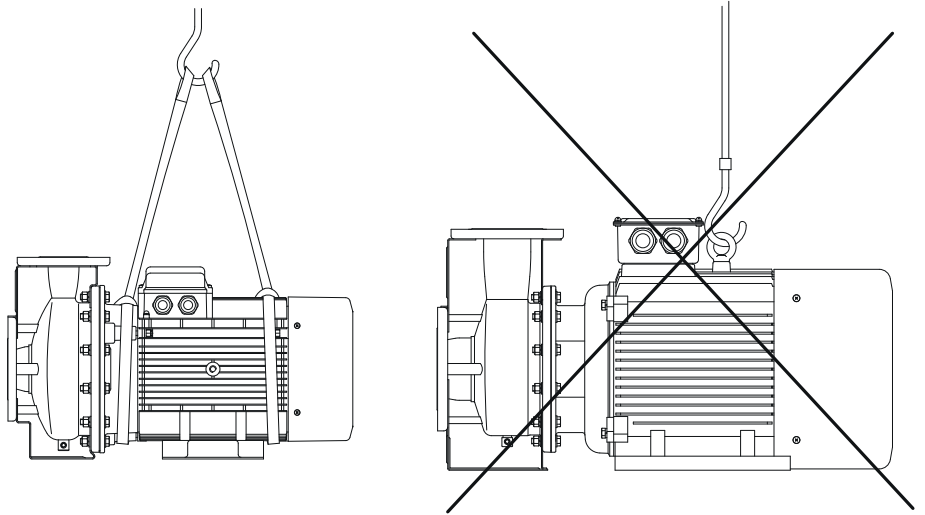

Fig. 1: Transporting the pump

For lifting with a crane, the pump must be supported by suitable belts or load ropes, as shown. Place belts or load ropes in loops around the pump, which tighten from the pump's own net weight.

The transport lugs on the motor are only for guiding when the load is being carried! Never lift or transport the load only by the transport lugs.



WARNING

Damaged transport lugs can break off and cause considerable personal injury.

- Check the transport lugs before use for damage and secure fixation.



DANGER

Danger of death from falling parts!

The pump itself and pump parts can have a very high net weight. Falling parts pose a risk of cuts, crush injuries, bruises or impacts, which can be fatal.

- Always use suitable lifting accessories and secure parts against falling.
- Never stand below a suspended load.
- During storage and transport, as well as before all installation and assembly work, ensure that the pump is in a safe position and standing securely.



WARNING

Personal injury due to unsecured installation of the pump!

If the motor support has been removed, the pump can fall over when stationary and injure people.

- Never set the pump down without motor support.

3.3 Storage

CAUTION

Damage due to incorrect handling during transport and storage!

Protect the product from moisture, frost and mechanical damage during transport and temporary storage.

Leave stickers on the pipe connections so that no dirt and other foreign matter can get into the pump housing.

To prevent scoring at the bearings and sticking, rotate the pump shaft once a week.
If a longer storage time is required, contact Wilo for preservation measures.



WARNING

Risk of injury due to incorrect transport!

If the pump is transported again at a later date, it must be packaged so that it cannot be damaged during transport. Use the original packaging for this or choose equivalent packaging.

4 Intended use and misuse

4.1 Intended use

Pumps from the Atmos BST series are made entirely of AISI 304 and 316 stainless steel and can therefore be used for pumping water as well as non-aggressive and slightly aggressive fluids without solids in the following systems:

- Hot water heating systems
- Chilled and cooling water systems
- Water systems for industrial use
- Industrial circulation systems
- Heat transfer media circulation
- OEM application

Intended use includes compliance with these instructions as well as the information and markings on the pump.

Any use beyond the intended use is considered misuse and will result in the loss of all liability claims.

4.2 Misuse

The operational reliability of the supplied product is only guaranteed for intended use in accordance with chapter "Intended use" of the installation and operating instructions. The limit values must not fall below or exceed those values specified in the catalogue/data sheet.



WARNING

Misuse of the pump can lead to dangerous situations and damage!

Non-permitted substances in the fluid can destroy the pump. Abrasive solids (e.g. sand) increase pump wear.

Pumps without an Ex rating are not suitable for use in potentially explosive atmospheres.

- Never use fluids other than those approved by the manufacturer.
- Highly flammable materials/fluids should always be kept at a safe distance from the device.
- Never allow unauthorised persons to carry out work.
- Never operate the pump beyond the specified limits of use.
- Never carry out unauthorised conversions.
- Use authorised accessories and original spare parts only.

5 Product information

5.1 Type key

Example:

Atmos BST 32/125-7.5/2-V4

Atmos	Product family
BST (Block Stamped)	Standard
32	Nominal diameter DN in mm on the discharge side
125	Impeller nominal diameter in mm
7.5	Rated power P2 in kW
2	Number of poles

Example:**Atmos BST 32/125-7.5/2-V4**

6	Without code: 50 Hz version 6: 60 Hz version
-V1	3~230/400 V, 50Hz
-V2	3~400/690 V, 50Hz
-V4	1~230 V, 50 Hz
-H12	Pump housing 1.4401

Table 1: Type key

Example:**Atmos BST 25/160-1.1/2/6-V5**

Atmos	Product family
BST (Block Stamped)	Standard
25	Nominal diameter G1 in mm on the discharge side (female thread)
160	Impeller nominal diameter in mm
1.1	Rated power P2 in kW
2	Number of poles
6	Without code: 50 Hz version 6: 60 Hz version
-V5	3~220/380 V, 60Hz
-V9	1~208 ... 230 V, 60 Hz
-H12	Pump housing 1.4401

Table 2: Type key

5.2 Technical data

Property	Value	Note
Rated speed	2900 rpm	
Nominal diameters DN	DN 32 ... DN 100 mm G1 ... G1½	
Pipe and pressure measurement connections	Flange PN 16 in accordance with DIN EN 1092-1	
Permissible min./max. fluid temperature	-20 °C ... +120 °C with mechanical seal	
Maximum permissible ambient temperature	+50 °C	
Max. permissible operating pressure	10 bar	
Insulation class	F	
Protection class	IP55	
Permissible fluids	Heating water in accordance with VDI 2035 part 1 and part 2 Process water Cooling/chilled water Water-glycol mixture ¹⁾ Heat-conducting oil	Standard version Standard version Standard version Special version
Permissible fluids	Other fluids (on request)	Special version (at additional charge)

Property	Value	Note
Electrical connection	1~220 V, 50 Hz (≤ 2.2 kW)	Standard version
	3~220 V, 50 Hz (≤ 3 kW)	Standard version
	3~380 V, 50 Hz (> 3 kW)	Standard version

¹⁾Note that water-glycol mixtures or fluids with a viscosity that is different to that of pure water increase the power consumption of the pump.

The pumping data must be adjusted according to the higher viscosity of the fluid, regardless of the proportion of viscous substances.

Only use brand products with anti-corrosion inhibitors. Strictly follow the manufacturer's instructions and safety data sheets!

When ordering spare parts, specify all data on the pump/motor rating plate.

Table 3: Technical data

5.3 Scope of delivery

- Pump
- Installation and operating instructions

5.4 Accessories

Accessories must be ordered separately.

See catalogue for detailed list.

6 Description of the pump

Monobloc pump, installation dimensions and hydraulics according to DIN EN 733. The pumps can be installed directly in a sufficiently anchored pipe as an in-line pump or placed on a base.

Pump with feet screwed to the pump housing.

For threaded pipe union pumps with screwed-on motor support.

6.1 Anticipated noise levels

Expected noise values as guideline.

Motor power P ₂ [kW]	Measuring surface sound-pressure level L _{p, A} [dB(A)] ¹⁾
	2900 rpm
0.55	73.1
0.75	74.4
1	75.6
1.1	76.0
1.5	77.3
1.85	78.2
2.2	78.9
3	80.2
4	81.4
5.5	82.8
7.5	84.1
9.2	84.9
11	85.7
15	87.0
18.5	87.9
22	88.6
30	89.9
37	90.8

¹⁾ Spatial mean value of sound-pressure levels on a square measuring surface at a distance of 1 m from the surface of the motor.

Table 4: Anticipated noise levels (50 Hz)

7 Installation

7.1 Personnel qualifications

- Installation/dismantling: The technician must be trained in the use of the necessary tools and fixation materials.

7.2 Operator responsibilities

- Observe national and regional regulations!
- Observe locally applicable accident prevention and safety regulations of professional and trade associations.
- Provide protective equipment and ensure that the protective equipment is worn by personnel.
- Observe all regulations for working with heavy loads.

7.3 Safety



DANGER

Danger of death due to lack of protective devices!

Due to missing protective devices of the terminal box or near the coupling/motor, electric shock or contact with rotating parts can lead to life-threatening injuries.

- Before commissioning, safety devices such as coupling covers that were removed must be reinstalled!



DANGER

Danger of death from falling parts!

The pump itself and pump parts can have a very high net weight. Falling parts pose a risk of cuts, crush injuries, bruises or impacts, which can be fatal.

- Always use suitable lifting accessories and secure parts against falling.
- Never stand below a suspended load.
- During storage and transport, as well as before all installation and assembly work, ensure that the pump is in a safe position and standing securely.



WARNING

Hot surface!

The entire pump can become very hot. There is a risk of burns!

- Allow the pump to cool down before commencing any work!



WARNING

Risk of scalding!

At high fluid temperatures and system pressures, allow the pump to cool down first and then depressurise the system.

CAUTION

Damage to the pump due to overheating!

The pump must not be allowed to run dry for more than 1 minute. Dry running causes a build-up of energy in the pump, which can damage the shaft, impeller, and mechanical seal.

- Make sure that the volume flow does not fall below the minimum value Q_{\min} .

Calculation of Q_{\min} :

$$Q_{\min} = 10 \% \times Q_{\max \text{ pump}}$$

7.4 Preparing the installation

Check whether the pump complies with the specifications on the delivery note; report any damage or missing parts to Wilo immediately. Check slatted crates/boxes/wrapping for spare parts or accessory components that could be included with the pump.



WARNING

Risk of personal injury and property damage due to improper handling!

- Never set up the pump unit on unfortified surfaces or surfaces that cannot bear loads.
- Flush the pipeline system if required.
 - Dirt can cause the pump to fail.
- Install only after completion of all welding and soldering work and after the pipeline system has been flushed, if required.
- Observe the minimum axial distance between a wall and the fan cover of the motor: 200 mm + diameter of the fan cover.



NOTICE

Simplify subsequent work on the unit!

- To ensure the entire unit does not have to be emptied, install shut-off valves upstream and downstream of the pump.



NOTICE

The motor terminal box must not face downward.

7.4.1 Installation location

- The pump must be protected from the weather and installed in a frost-/dust-free, well ventilated, oscillation-isolated environment that is not potentially explosive. The pump must not be installed outdoors! Observe the specifications in "Intended use" section!
- Mount the pump in a readily accessible place. This makes it easier to complete inspections, maintenance or replacement in the future.
Lay the suction pipe as short as possible.
- Install a device for attaching hoisting gear above the set-up site of the pumps. Total weight of the pump: see catalogue or data sheet.

7.4.2 Base

The pump units can be mounted on their foundations in many different ways. The type of fixation depends on the size and location of the pump unit as well as noise and vibration regulations.



NOTICE

For some pump types, simultaneous separation of the foundation block itself from the building structure by means of an elastic intermediate layer (e.g. cork or MAFUND® plate) is required for vibration-insulated installation.

CAUTION

A faulty foundation or incorrect installation of the unit!

A faulty foundation or incorrect installation of the unit on the foundation can lead to defects of the pump.

These defects are not covered by the warranty.

- Allow the concrete foundation to harden before installing the pump unit. The surface must be flat and even.
- Never set up the pump unit on unfortified surfaces or surfaces that cannot bear loads.

The baseplate must be mounted on a firm base. The foundation must be made of high-quality concrete of sufficient thickness.

The baseplate must not be warped or pulled down on the surface of the foundation. It must be supported so that the original alignment remains unchanged.

To anchor the baseplate sufficiently, the dimensions of the fastening screws are selected/recommended in accordance with holes drilled in the baseplate:

Drilled hole in the base-plate Ø [mm]	Thread	Screw length [mm]	Thread length [mm]
12	M10	120	36
15	M12	160	40
18.5	M16	200	50

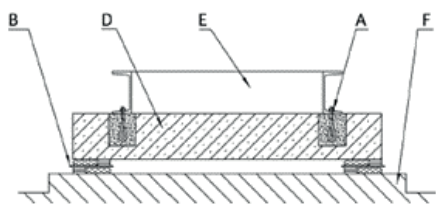
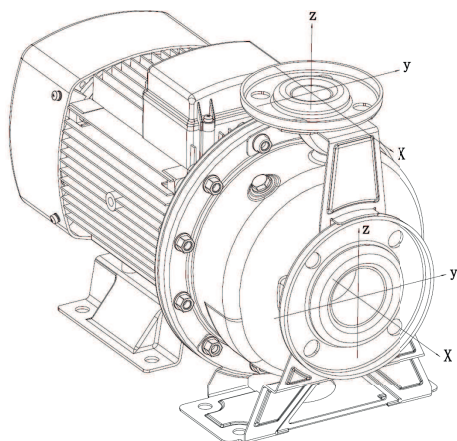

Fig. 2: Example of a foundation screwed connection

7.4.3 Permissible forces and torques on the pump flanges



DN	Forces F [N]				Torques M [Nm]			
	F _x	F _y	F _z	Σ Forces F	M _x	M _y	M _z	Σ Torques M
Discharge and suction flange								
32	367.5	315.0	297.5	367.5	385.0	262.5	297.5	385.0
40	385.0	350.0	437.5	437.5	455.0	315.0	367.5	455.0
50	525.0	472.5	577.5	577.5	490.0	350.0	402.5	490.0
65	647.5	595.0	735.0	735.0	525.0	385.0	420.0	525.0
80	787.5	717.5	875.0	875.0	560.0	402.5	455.0	560.0
100	1050.0	945.0	1172.5	1172.5	595.0	437.5	507.5	595.0

Table 5: Permissible forces and torques on pump flanges

If not all working loads reach the maximum permitted values, one of these loads may exceed the normal limit value. Provided that the following additional conditions are fulfilled:

- All force and torque components are limited to 1.4 times the maximum permitted value.
- The forces and torques acting on each flange meet the requirements of the compensation equation.

$$\left(\frac{\sum |F|_{\text{effective}}}{\sum |F|_{\text{max. permitted}}} \right)^2 + \left(\frac{\sum |M|_{\text{effective}}}{\sum |M|_{\text{max. permitted}}} \right)^2 \leq 2$$

Fig. 3: Compensation equation

$\Sigma F_{\text{effective}}$ and $\Sigma M_{\text{effective}}$ are the arithmetic sums of the effective values of both pump flanges (inlet and outlet). $\Sigma F_{\text{max. permitted}}$ and $\Sigma M_{\text{max. permitted}}$ are the arithmetic sums of the maximum permitted values of both pump flanges (inlet and outlet). The algebraic signs of ΣF and ΣM are not considered in the compensation equation.

7.4.4 Connection of the pipes

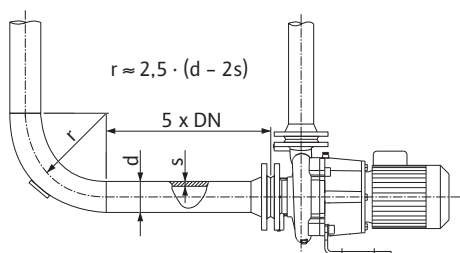

Fig. 4: Settling section upstream and downstream of the pump

CAUTION

Risk of damage due to incorrect handling!

The pump may never be used as a fixed point for the pipe.

- The present NPSH of the system always has to be greater than the required NPSH of the pump.
- The forces and torques being exerted by the pipeline system on the pump flange (e.g., by warping, thermal expansion) may not exceed the permitted forces and torques.
- The pipes and pump must be free of mechanical stress when installed.
- The pipes must be fixed in such a way that the pump does not have to support the weight of the pipes.
- The suction line is to be kept as short as possible. Lay the suction line to the pump so that it continuously rises while the inlet falls. Avoid possible air entry points.
- If a dirt trap in the suction line is required, its free cross-section has to be 3 – 4 times the cross-section of the pipe.
- For short pipes, the nominal diameters must be at least those of the pump connections. For long pipes, determine the most economical nominal diameter in each case.
- To avoid higher pressure losses, make adapters for larger nominal diameters with an extension angle of approx. 8°.
- Minimum axial distance between a wall and the fan cover of the motor: free removal dimension of at least 250 mm + ϕ of the fan cover.



NOTICE

Avoid flow cavitation!

- A settling section must be provided upstream and downstream of the pump in the form of a straight pipe. The length of the settling section must be at least 5 times the nominal diameter of the pump flange.

7.4.5 Final check

8 Electrical connection

- Remove the flange covers at the suction and discharge ports of the pump before attaching the piping.
 - Tighten the foundation bolts if necessary.
 - Check all connections for correctness and function.
 - It must be possible to turn the pump shaft by hand.
- Electrical work: a qualified electrician must carry out the electrical work.



NOTICE

Nationally applicable guidelines, standards and regulations as well as the requirements of local energy supply companies must be observed!

CAUTION

Risk of material damage caused by improper electrical connection!

- Ensure that the current type and voltage of the mains connection correspond to the specifications on the motor rating plate.



DANGER

Risk of fatal electrical shock!

Immediate danger of death if live components are touched!
 • Check whether all connections are voltage-free!

- Main fuse: depending on the rated motor current.
- Earth the pump according to the instructions.
- Lay the connection cables so that they do not touch the piping or the pump or motor housing.



NOTICE

The connection diagram for the electrical connection is located in the terminal box.

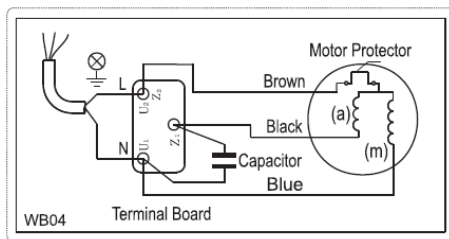

Fig. 5: Alternating current

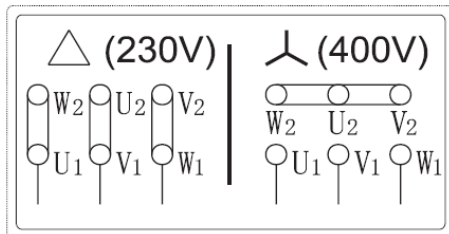

Fig. 6: Y-Δ-connection

The special motor model is fitted with passive thermal control. This thermal control can be connected via the corresponding terminals in the terminal box. The passive thermal control should always be connected to the thermal trip mechanism!

CAUTION

Risk of material damage!

Only a max. voltage of 7.5 V DC may be applied to the terminals of the passive thermal control. A higher voltage will destroy the PTC thermistor sensor.

- It is advisable to install a motor protection switch.

Setting the motor protection switch:

- Direct starting current: The information on the motor rating plate pertaining to the rated current must be observed for the installation.
- Y-Δ start: If the motor protection switch is switched in the supply line to a Y-Δ contactor combination, adjust the switch as for direct starting. If the motor protection switch is switched in a thread of the motor supply line (U1/V1/W1 or U2/V2/W2), set the motor protection switch to the value 0.58 x rated motor current.
- The mains connection depends on the motor power P_2 , mains voltage and activation type. Refer to the following table and Fig. 4 and Fig. 5 for the required connection of the connecting bridges in the terminal box.

Activation type	Motor power $P_2 \leq 3$ kW		Motor power $P_2 > 3$ kW	Motor power $P_2 < 2.2$ kW
	Mains voltage 3~ 230 V	Mains voltage 3~ 400 V	Mains voltage 3~ 380 V	Mains voltage 1~ 230 V
Direct	Δ-connection (Fig. 5)	Y-connection (Fig. 5)	Δ-connection (Fig. 5)	Connection (Fig. 4)
Y-Δ start	Remove connection bridges. Fig. 5 (Y)	Not possible	Remove connection bridges. Fig. 5 (Y)	

Table 6: Terminal assignment

- When connecting automatic switchgears, observe the corresponding installation and operating instructions.
- For three-phase current motors with Y-Δ connection, be sure that the switchover points between star and delta are very close together in time. **Longer switchover times can lead to pump damage.**

Recommended time setting for Y-Δ activation:

Motor power	Time to be set
≤ 30 kW	< 3 seconds

Motor power	Time to be set
> 30 kW	< 5 seconds

9 Commissioning

- Electrical work: a qualified electrician must carry out the electrical work.
- Installation/dismantling: The technician must be trained in the use of the necessary tools and fixation materials.
- The product must be operated by persons who have been instructed on how the complete system functions.



DANGER

Danger of death due to lack of protective devices!

Due to missing protective devices of the terminal box or in the range of the coupling/motor, electric shock or contact with rotating parts can lead to life-threatening injuries.

- Before commissioning, safety devices such as terminal box covers or coupling covers that were removed must be reinstalled!
- An authorised technician must check the functionality of the safety devices on the pump and motor prior to commissioning!



WARNING

Danger of injury due to fluid shooting out and components coming loose!

Not installing the pump/system correctly can lead to serious injuries during commissioning!

- Carry out all work carefully!
- Keep a safe distance during commissioning!
- Always wear protective clothing, safety gloves and safety glasses when working.



NOTICE

It is recommended to have the pump commissioned by the Wilo customer service.

Preparation

- The pump has to reach ambient temperature before commissioning.
- The pump. suction and supply pipes must be filled and the air must be removed.

9.1 Filling and venting

CAUTION

Dry running will destroy the mechanical seal! It may cause leakage.

- Ensure that a dry run of the pump is not possible.



WARNING

There is a risk of burns or freezing upon coming into contact with the pump/system.

Depending on the pump and system operating conditions (fluid temperature), the entire pump can become very hot or very cold.

- Keep a safe distance during operation!
- Allow the system and pump to cool down to room temperature!
- Always wear protective clothing, safety gloves and safety glasses when working.



DANGER

Danger of personal injury and material damage due to extremely hot or extremely cold pressurised fluid!

Depending on the temperature of the fluid, when the venting device is opened completely, **extremely hot** or **extremely cold** fluid may escape in liquid or vapour form. Fluid may shoot out at high pressure depending on the system pressure.

- Always exercise caution when opening the venting device.

1. Close shut-off device at the outlet.
2. Fill pump via the suction pipe, whereby the shut-off device at the inlet is to be fully opened.
3. Deaerate pump via venting screw in pump housing until only fluid appears.
4. Close venting screw.



NOTICE

- Always keep to the minimum pressure!

- To avoid cavitation noises and damage, a minimum inlet pressure must be guaranteed at the suction port of the pump. The minimum inlet pressure depends on the operating situation and the pump's duty point. Accordingly, the minimum pressure must be determined.
 - The main parameters for defining the minimum inlet pressure are the NPSH value of the pump at its duty point and the vapour pressure of the fluid.
1. By briefly switching on, check whether the direction of rotation agrees with the arrow on the fan cover. If the direction of rotation is incorrect, proceed as follows:
 - For direct starting: Swap two phases on the motor terminal board (e.g. L1 for L2).
 - For Y- Δ starting:
Swap the thread start and thread end of two windings on the motor terminal board (e.g. V1 for V2 and W1 for W2).

CAUTION

Even brief dry running will destroy the mechanical seal!

Only carry out the direction of rotation monitoring after the system is filled!

9.2 Activation

- The unit may only be switched on when the shut-off device on the discharge side is closed! Only after full speed has been reached may the shut-off device be slowly opened and be adjusted to the duty point.

The unit must run smoothly and free of oscillation.

The mechanical seal ensures that a seal will not leak and requires no special setting. Should there be a small leakage at the beginning, it will stop when the initial inlet phase of the gasket is over.

After the operating temperature has been reached and/or in the event of leaks in the pump housing, re-tighten the hexagonal screws with the set switched off.



DANGER

Danger of death due to lack of protective devices!

Due to missing protective devices of the terminal box or near the coupling/motor, electric shock or contact with rotating parts can lead to life-threatening injuries.

- Immediately after the conclusion of all work, all the provided safety and protection equipment items must be properly installed and put into operation!

9.3 Switching off

- Close the shut-off device in the discharge line.



NOTICE

If a non-return valve is installed in the discharge line, and there is counterpressure, the shut-off device can remain open.

CAUTION

Risk of damage due to incorrect handling!

When switching off the pump, the shut-off device in the inlet pipe must not be closed.

- Switch off the motor and allow it to coast down completely. Ensure the coasting is smooth.
- For longer downtimes, close the shut-off device in the inlet pipe.
- For longer periods of non-use and/or danger of freezing, drain the pump and secure it against freezing.
- After removing the pump, store it in a dry and dust-free place.

9.4 Operation



NOTICE

The pump must always run smoothly and vibration-free and must not be operated in conditions other than those specified in the catalogue/data sheet.



DANGER

Danger of death due to lack of protective devices!

Due to missing protective devices of the terminal box or near the coupling/motor, electric shock or contact with rotating parts can lead to life-threatening injuries.

- Immediately after the conclusion of all work, all the provided safety and protection equipment items must be properly installed and put into operation!



WARNING

There is a risk of burns or freezing upon coming into contact with the pump/system.

Depending on the pump and system operating conditions (fluid temperature), the entire pump can become very hot or very cold.

- Keep a safe distance during operation!
- Allow the system and pump to cool down to room temperature!
- Always wear protective clothing, safety gloves and safety glasses when working.

The pump can be switched on and off in different ways. This depends on the different operating conditions and the degree of automation of the installation. Observe the following points:

Stop procedure:

- Prevent return flow to the pump.
- Do not operate for too long with the volume flow being too low.

Start procedure:

- Make sure that the pump is completely filled up.
- Ensure a continual flow to the pump with a sufficiently large NPSH.
- Avoid that insufficient counter pressure leads to a motor overload.

10 Maintenance

- To avoid significant increases in motor temperature and excessive load on the pump, coupling, motor, gaskets and bearings, perform no more than 10 switch-on procedures per hour.
- Maintenance work: The technician must be familiar with the use of operating fluids and their disposal.
- Electrical work: a qualified electrician must carry out the electrical work.
- Installation/dismantling: The technician must be trained in the use of the necessary tools and fixation materials.

It is recommended to have the pump serviced and checked by the Wilo customer service.



DANGER

Danger of death due to electrical current!

Improper conduct when carrying out electrical work can lead to death due to electric shock!

- Any work on electrical devices may only be carried out by a qualified electrician.
- Before carrying out any work, disconnect the unit from the power supply and secure it against accidental switch-on.
- Any damage to the pump connection cable should only ever be rectified by a qualified electrician.
- Follow the installation and operating instructions for the pump, level control device and other accessories.
- Never poke around in the motor openings or insert anything into them.
- After completing the work, refit previously dismantled protective devices, for example, terminal box covers or coupling covers.



DANGER

Danger of death from falling parts!

The pump itself and pump parts can have a very high net weight. Falling parts pose a risk of cuts, crush injuries, bruises or impacts, which can be fatal.

- Always use suitable lifting accessories and secure parts against falling.
- Never stand below a suspended load.
- During storage and transport, as well as before all installation and assembly work, ensure that the pump is in a safe position and standing securely.



DANGER

Danger of death due to ejected tools!

The tools used during maintenance work on the motor shaft can be thrown away if they come into contact with rotating parts. Injuries and even death are possible!

- The tools used during maintenance work must be removed completely before the pump is started up!



WARNING

There is a risk of burns or freezing upon coming into contact with the pump/system.

Depending on the pump and system operating conditions (fluid temperature), the entire pump can become very hot or very cold.

- Keep a safe distance during operation!
- Allow the system and pump to cool down to room temperature!
- Always wear protective clothing, safety gloves and safety glasses when working.

10.1 Maintenance work



DANGER

Danger of death from falling parts!

Falling pumps or individual pump components may result in life-threatening injuries!

- During installation work, secure pump components against falling down with suitable lifting gear.



DANGER

Risk of fatal electrical shock!

Check for absence of voltage and cover or cordon off adjacent live parts.

10.1.1 On-going maintenance

Replace all gaskets that have been removed for maintenance.

10.1.2 Rolling bearing

Rolling bearings with lubricating grease have been added before delivery. Please add or replace the lubricating grease as specified on the motor rating plate after operation of the equipment.

Do not reuse rolling bearings following disassembly for maintenance work!

10.1.3 Mechanical seal

There may be a slight amount of drip leakage during the running-in period. Even during normal operation of the pump, it is normal for there to be slight leakage with the occasional formation of drops.

In addition, carry out a visual inspection regularly. If there is clearly detectable leakage, a gasket must be replaced.

Contact Wilo Service for this.

11 Faults, causes and remedies



WARNING

Have faults remedied by qualified personnel only! Observe all safety instructions!

If the malfunction cannot be rectified, consult a specialist technician or the nearest Wilo customer service or representative location.

Faults	Causes	Remedy
The pump does not deliver any volume flow	<ul style="list-style-type: none"> • Suction and discharge lines or impeller clogged • Pump sucks air or the suction line is leaky • Pump and/or piping not completely filled 	<ul style="list-style-type: none"> • Remove clogging • Replace gasket, check suction line • Vent pump and fill suction line

Faults	Causes	Remedy
Insufficient volume flow	<ul style="list-style-type: none"> • Impeller damaged and corroded • Seal ring damaged and corroded • Motor speed is lower than required 	<ul style="list-style-type: none"> • Replace impeller • Replace gasket • Check voltage
Delivery head losses	<ul style="list-style-type: none"> • Incorrect direction of rotation • Min. inlet pressure too low or negative suction head too high • Impeller damaged and corroded 	<ul style="list-style-type: none"> • Change motor wiring (3 phase motor: swap phases) • Correct liquid level, reduce resistances in the suction line • Replace impeller
Motor overheating	<ul style="list-style-type: none"> • Volume flow is outside the permissible field of application • Voltage higher than rated voltage • Voltage too low, fan works too slowly • Motor fan damaged 	<ul style="list-style-type: none"> • Adhere to recommended minimum volume flow • Check voltage • Check voltage • Check motor fan
Leakage at the pump	<ul style="list-style-type: none"> • Housing screws not tightened 	<ul style="list-style-type: none"> • Tighten the housing screws
Noise, bearings become hot	<ul style="list-style-type: none"> • Motor bearings damaged • The pump is strained 	<ul style="list-style-type: none"> • Have bearings replaced • Correct the pump installation
Pump makes noises	<ul style="list-style-type: none"> • Volume flow rate is outside the permissible field of application and causes the delivery head loss 	<ul style="list-style-type: none"> • Adhere to recommended minimum volume flow
Pump does not start	<ul style="list-style-type: none"> • Power supply failure • Fuses have tripped or blown • Motor protection switch has been triggered • Thermal protection has tripped out • Motor is malfunctioning 	<ul style="list-style-type: none"> • Check power supply • Replace fuses • Reactivate the motor protection • Reactivate the thermal protection • Replace motor (contact service)
Motor overload trips out immediately when power supply is activated	<ul style="list-style-type: none"> • A fuse/circuit breaker has tripped or blown • Cable connection is loose or faulty • Motor winding is defective • Pump mechanically clogged 	<ul style="list-style-type: none"> • Cut in the fuse • Fasten or replace the cable connection • Replace motor (contact service) • Remove clogging
Motor overload trips out occasionally	<ul style="list-style-type: none"> • Overload setting is too low • Low voltage at peak times 	<ul style="list-style-type: none"> • Set motor protection switch correctly • Check power supply
Pump capacity not constant	<ul style="list-style-type: none"> • Pump inlet pressure is too low (cavitation) • Suction pipe/pump partly clogged by impurities • Pump draws in air 	<ul style="list-style-type: none"> • Check the suction conditions • Clean pump and supply line • Check the suction conditions

Faults	Causes	Remedy
Pump runs but provides no water	<ul style="list-style-type: none"> Suction pipe/pump clogged by impurities Foot or non-return valve blocked in closed position Leakage in suction pipe Air in suction pipe or pump Incorrect direction of rotation of the motor 	<ul style="list-style-type: none"> Clean pump and suction pipe Repair the foot or non-return valve Repair the suction pipe Check the suction conditions, vent the system Change motor wiring (3 phase motor: swap phases)
Pump runs backwards when switched off	<ul style="list-style-type: none"> Leakage in suction pipe Foot or non-return valve is defective 	<ul style="list-style-type: none"> Remove leakage Repair the foot or non-return valve
Mechanical seal leakage	Mechanical seal is defective	Replace mechanical seal (contact service)
Noise	<ul style="list-style-type: none"> Cavitation occurs in the pump Pump does not rotate freely (friction resistance) because of the incorrect pump shaft position Ratio of system pressure to pump pressure is too low Frequency converter not running 	<ul style="list-style-type: none"> Check the suction conditions Realign pump shaft Improve system or choose a suitable pump Check the frequency converter operation

Table 7: Mechanical faults

12 Spare parts

Obtain original spare parts only from a qualified specialist or Wilo customer service. To avoid queries and order errors, please provide all pump and drive rating plate data with every order.

It is recommended that maintenance and repair work on the pump is only carried out by Wilo or authorised specialists!

CAUTION

Risk of material damage!

Trouble-free pump operation can only be guaranteed when original spare parts are used.

Use only original Wilo spare parts!

Information to be provided when ordering spare parts: Spare part numbers, spare part designations, all data from pump and drive rating plate. This helps prevent return queries and incorrect orders.

Specify the number of spare parts required!

12.1 Recommended stocking of spare parts for two-year continuous operation

Part no.	Designation	Number of pumps (including standby pumps)						
		2	3	4	5	6 and 7	8 and 9	10 and more
		Number of spare parts						
4	Impeller	1	1	1	2	2	3	30%
-	Ball bearing	2	2	4	4	6	8	100%
6/3	Mechanical seal	2	2	4	4	6	8	100%
2/8	Flat gasket/O-ring (set)	4	6	8	8	9	12	150%

12.2 Spare parts list

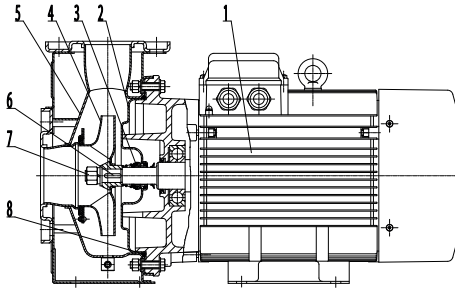
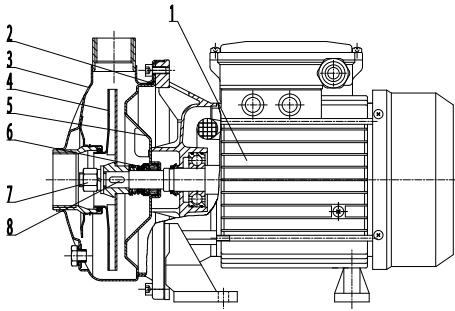

Item	Item description	Material	Number
1	Motor		1
2	O-ring	EPDM	1
3	Pump housing	SUS304	1
4	Impeller	SUS304	1
5	Discharge cover	SUS304	1
6	Mechanical seal		1
7	Hexagon nut	SUS304	1
8	Key	SUS304	1

Item	Item description	Material	Number
1	Motor		1
2	Discharge cover	EPDM	1
3	Mechanical seal		1
4	Impeller	SUS304	1
5	Pump housing	SUS304	1
6	Key	SUS304	1
7	Hexagon nut	SUS304	1
8	O-ring	EPDM	1

13 Disposal

13.1 Oils and lubricants

13.2 Information on the collection of used electrical and electronic products

Operating fluids must be collected in suitable containers and disposed of in accordance with the locally applicable guidelines. Wipe up drips immediately!

Proper disposal and appropriate recycling of this product prevents damage to the environment and danger to your personal health.



NOTICE

Disposal in domestic waste is prohibited!

In the European Union this symbol may be included on the product, the packaging or the accompanying documentation. It means that the electrical and electronic products in question must not be disposed of along with domestic waste.

Please note the following points to ensure proper handling, recycling and disposal of the used products in question:

- Hand over these products at designated, certified collection points only.
- Observe the locally applicable regulations!

Please consult your local municipality, the nearest waste disposal site, or the dealer who sold the product to you for information on proper disposal. See www.wilo-recycling.com for more information about recycling.

Subject to change without prior notice!







wilo



Local contact at
www.wilo.com/contact

Pioneering for You

WILO SE
Wilopark 1
44263 Dortmund
Germany
T +49 (0)231 4102-0
T +49 (0)231 4102-7363
wilo@wilo.com
www.wilo.com