

PATENTED



Construction

5" Vertical multi-stage close coupled **submersible or surface pumps.**

External jacket in stainless steel AISI 304 and stages Noryl.

MPSUM with built-in capacitor, accessible through the delivery casing.

Suction connection on the lower casing and delivery connection on the top casing.

Motor cooled by the pumped water passing between the motor jacket and the external jacket.

Double mechanical shaft seal with interposed oil chamber.

Applications

For clean water without abrasives or additives aggressive for the materials of the pump.

For domestic, civil and industrial applications.

For installation in confined space with minimum ventilation.

For installation in locations subject to risk of temporary flooding, the pump can be fully immersed.

For installation in areas exposed to water jetting.

When low-noise operation is required.

Operating conditions

Water temperature up to 35 °C.

Maximum permissible pressure in the pump casing: 8 bar.

Continuous duty.

Motor

2-pole induction motor, 50 Hz ($n \approx 2900$ 1/min).

MPSU : three-phase 230 V \pm 10%;

three-phase 400 V \pm 10%.

Cable: H07RN8-F, length 5 m, without plug.

MPSUM : single-phase 230 V \pm 10%, with thermal protector.

Incorporated capacitor.

Float switch MPSUM.. CG (on demand)

Cable: H07RN8-F, length 5 m, with plug CEI-UNEL 47166.

Insulation class F.

Protection IP X8 (for continuous immersion).

Triple impregnation humidity-proof dry winding.

Constructed in accordance with EN 60034-1;

EN 60335-1, EN 60335-2-41.

Special features on request

- Other voltages. - Frequency 60 Hz (as per 60 Hz data sheet).

- Cable length 15 m.

- Motor suitable operation with frequency converter.

Materials

Component	Material
Delivery casing External jacket Base Motor jacket	Chrome-nickel steel 1.4301 EN 10088 (AISI 304)
Stage casing Impeller	PPO-GF20 (Noryl)
Shaft	Chrome-nickel steel 1.4301 EN 10088 (AISI 304)
Capacitor cover Oil chamber cover Preload ring stages Support ring preload	PPS Polymer (Grivory)
Upper mechanical seal Lower mechanical seal	Steatite, carbon, NBR Carbon, silicon carbide, NBR
Seal lubrication oil	Oil for food machinery and pharmaceutical use

Coverage chart $n \approx 2900$ rpm

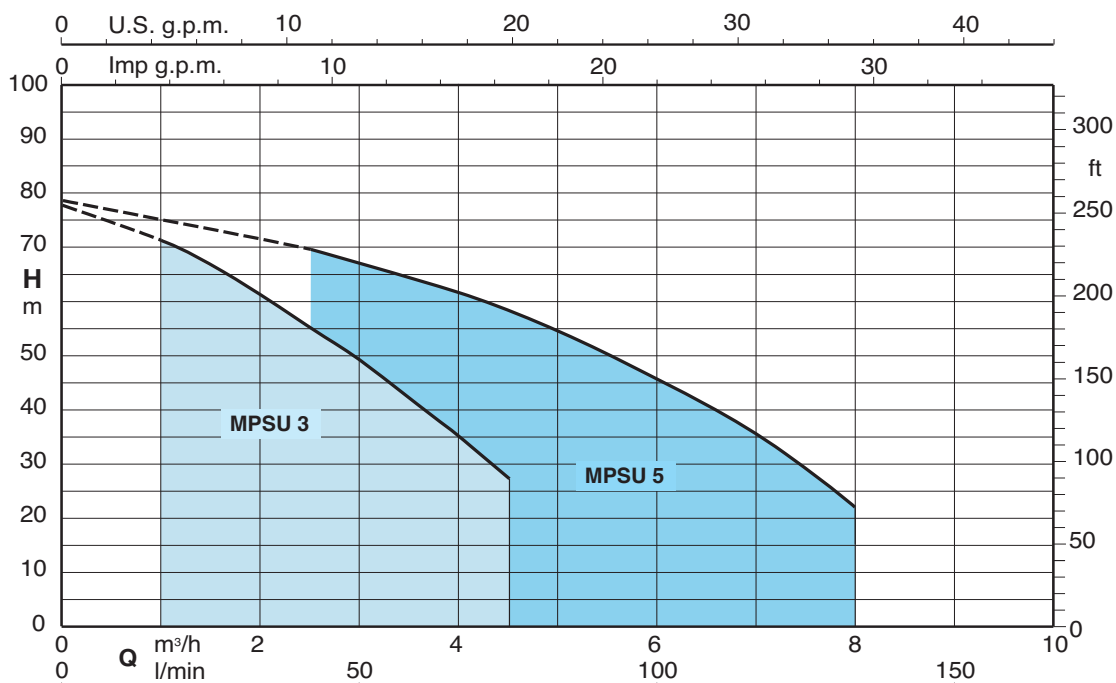

Performance $n \approx 2900$ rpm

	3 ~ 230 V 400 V		1 ~ 230 V	Capacitor		P ₁			P ₂			Q																		
	A	A		A	μ F	V	kW	kW	HP	m ³ /h	0	1	1,5	2	2,5	3	3,5	4	4,5	l/min	0	16,6	25	33,3	41,6	50	58,3	66,6	75	
MPSU 304	2,8	1,6	MPSUM 304	4,1	20	450	0,9	0,55	0,75	H m	44	41,5	39,5	36,5	33,5	29,5	25,5	21	16											
MPSU 305	3,3	1,9	MPSUM 305	5	20	450	1,1	0,75	1		54	49,5	46,2	43	30,9	35	30	25	19											
MPSU 306	3,8	2,2	MPSUM 306	6	25	450	1,3	0,9	1,2		66,5	60,5	57	53	48,5	43,5	38	32	26											
MPSU 307	4,5	2,6	MPSUM 307	6,6	25	450	1,5	0,9	1,2		75	67,5	63	58	53	47	41	34,5	27											

	3 ~ 230 V 400 V		1 ~ 230 V	Capacitor		P ₁			P ₂			Q																			
	A	A		A	μ F	V	kW	kW	HP	m ³ /h	0	2,5	3	3,5	4	4,5	5	6	7	8	l/min	0	41,6	50	58,3	66,6	75	83,3	100	116	133
MPSU 504	3,8	2,2	MPSUM 504	6	25	450	1,2	0,9	1,2	H m	45	39,5	37,8	35,8	33,5	31	28,5	23	16,5	9,5											
MPSU 505	4,5	2,6	MPSUM 505	7	25	450	1,5	1,1	1,5		53	47,5	45,5	43,5	41	38,5	35,5	29,5	22	13,5											
MPSU 506	4,8	2,8	MPSUM 506	8,3	30	450	1,7	1,1	1,5		66,5	58	55,6	53	50	46,3	42,5	34	24,5	14											
MPSU 507	6,9	4	MPSUM 507	12	35	450	2,2	1,5	2		78,5	69,5	66,5	64	61,5	58	54,5	45,5	36	22											

P1 Max. power input. P2 Rated motor power output. Tolerances according to UNI EN ISO 9906:2012 Test results with clean cold water, without gas content.

Dimensions and weights

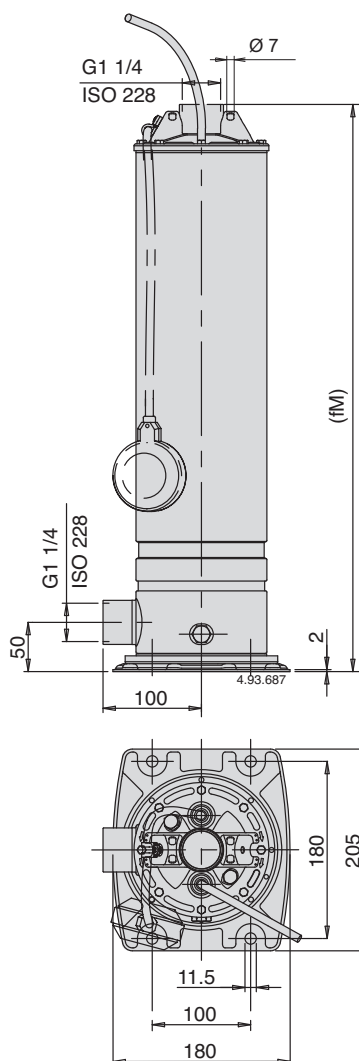

Weights with cable length: 5 m

PUMP	fM mm	kg		Cavo H07RN8-F		
		MPSU	MPSUM	230V 1~	230V 3~	400V 3~
MPSU 304 - MPSUM 304	553	11,4	12,4	3G1 mm ²	4G1 mm ²	4G1 mm ²
MPSU 305 - MPSUM 305	602	12,7	13,7	3G1 mm ²	4G1 mm ²	4G1 mm ²
MPSU 306 - MPSUM 306	650	13,3	14,8	3G1 mm ²	4G1 mm ²	4G1 mm ²
MPSU 307 - MPSUM 307	650	13,5	15	3G1 mm ²	4G1 mm ²	4G1 mm ²
MPSU 504 - MPSUM 504	602	13,1	14,1	3G1 mm ²	4G1 mm ²	4G1 mm ²
MPSU 505 - MPSUM 505	602	14	15	3G1 mm ²	4G1 mm ²	4G1 mm ²
MPSU 506 - MPSUM 506	671	15,5	17	3G1,5 mm ²	4G1 mm ²	4G1 mm ²
MPSU 507 - MPSUM 507	720	17	18,5	3G2,5 mm ²	4G1 mm ²	4G1 mm ²

MPSUM ... CG With float switch pump (on demand)

Characteristic curves $n \approx 2900$ rpm

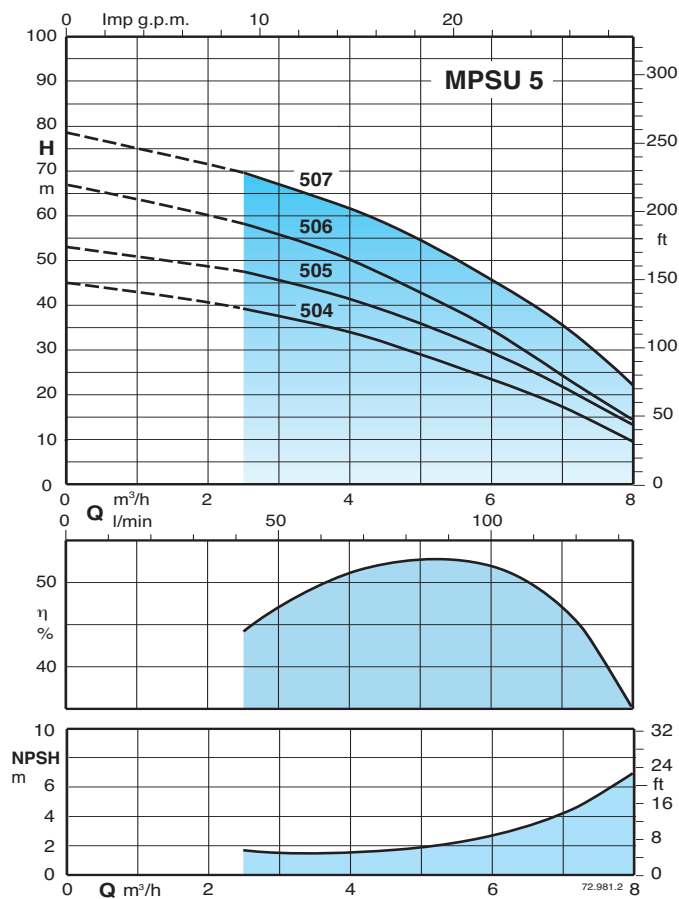
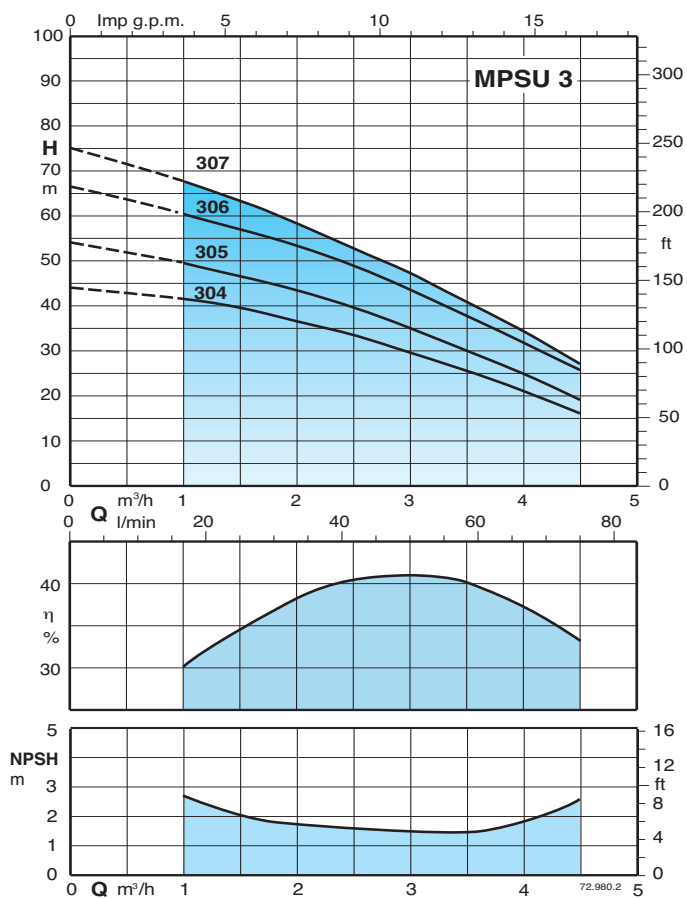

Installation examples

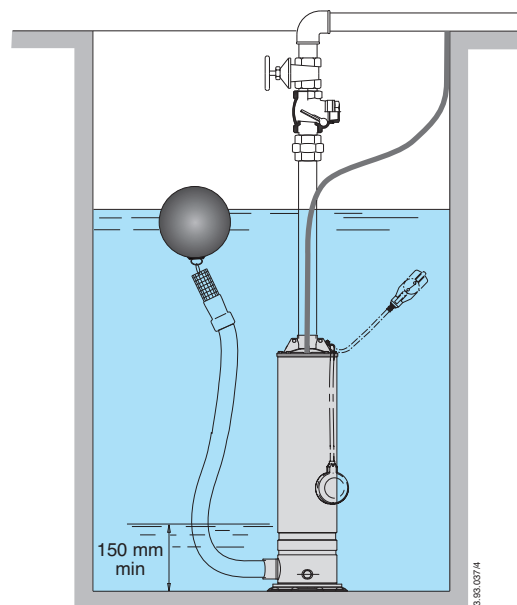
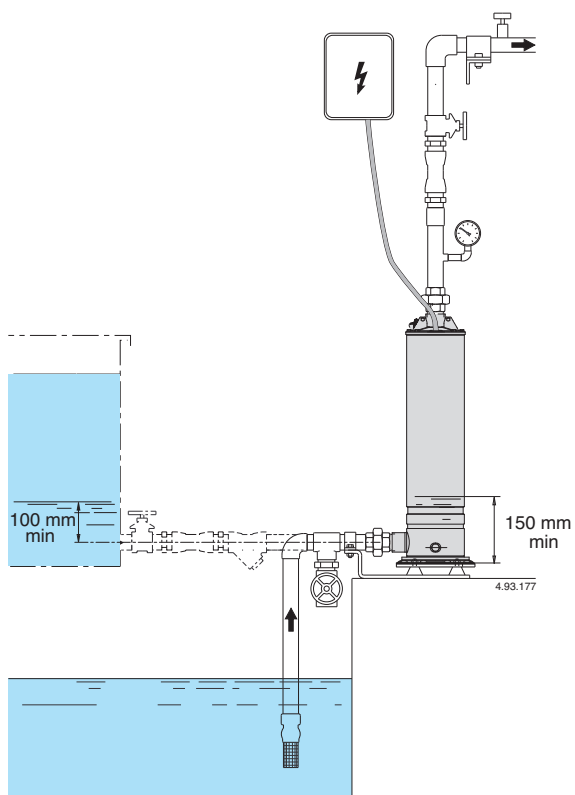

Features

Innovative

Designed to withstand water hammering and the ON-OFF operation of any valve located in the discharge line.

The impacts generated by water hammering or by the closing of the valve are fully supported by the capacitor cover, which relieves the stresses on a specific support made on the stainless steel jacket, without affecting the plastic hydraulic part.

Flexible

Allows the inspection of the capacitor without disassembling the pump, through the delivery casing.

Reliable

The ball bearings and shaft are sized in order to reduce stresses, guaranteeing high reliability in any operating condition.

PATENTED

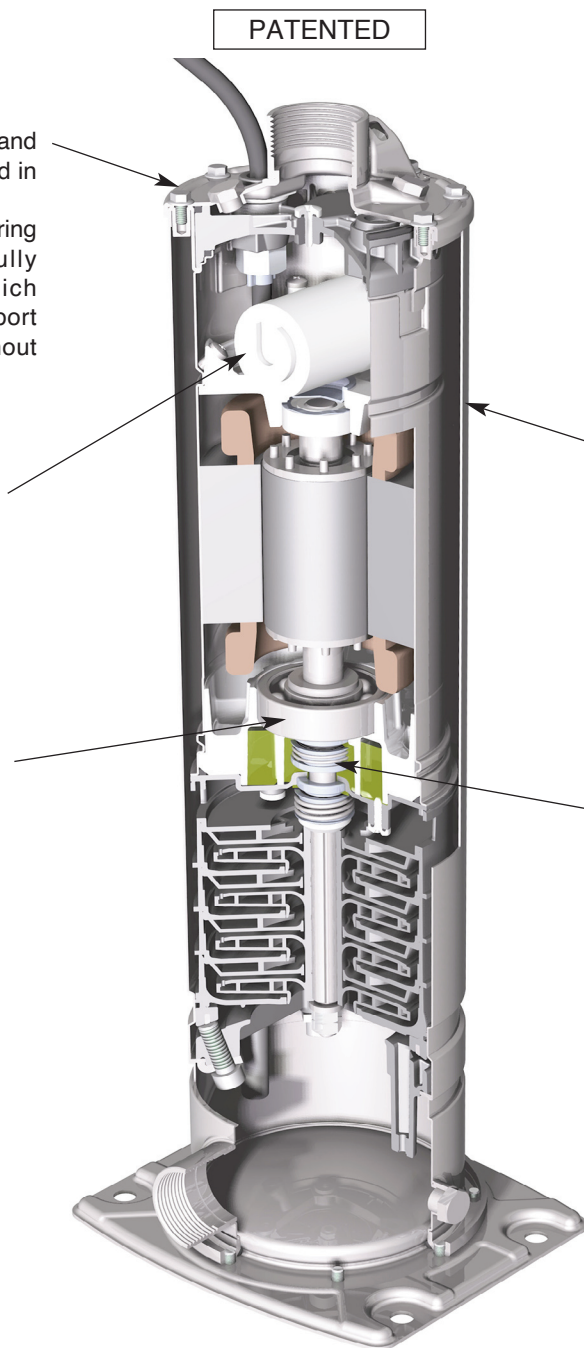

Low-Noise operation

The design of hydraulic parts, the water-filled shroud around the motor and the submerged operation ensures low noise operation.

Greater Safety

The double shaft sealing with an oil chamber separates the motor from the water and provides further protection against accidental operation when dry.