

# GQG



(patented system)



Coverage chart n  $\approx$  2900 rpm

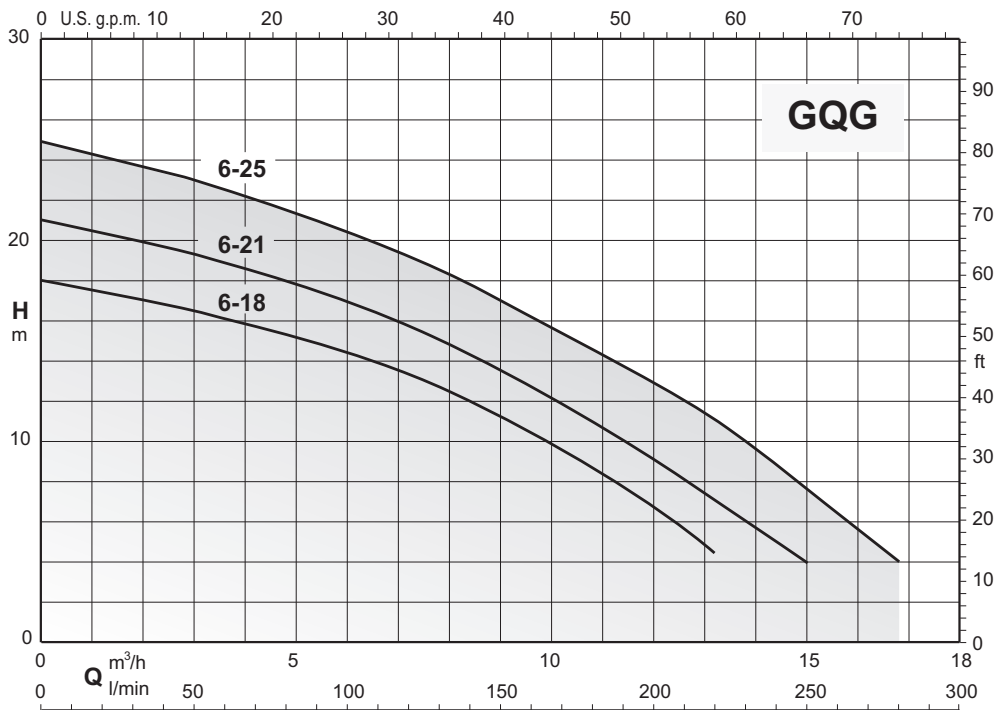

## Submersible pumps with high power grinder

### Construction

Submersible pumps with high-power grinding system, with threaded horizontal delivery port G 1 1/2 and flanged DN 32 PN 6.  
Double mechanical shaft seal with interposed oil chamber, to protect against dry-running.

### Applications

To move water containing long filamentary materials, paper or textile material. They are particularly suitable for use in domestic, residential and industrial installations  
Solid passage Ø 6 mm

### Operating conditions

Maximum liquid temperature: 35 °C  
Immersion depth: 5 m max  
Minimum immersion depth: 300 mm.  
Continuous duty (with submerged motor).

### Motor

2-pole induction motor, 50Hz (n ≈ 2900 1/min).  
**GQG:** three-phase 230V ± 10%  
400V ± 10%  
**GQGM:** single-phase 230V ± 10%  
With switch and float, thermal protector and control panel with starting capacitors.  
H07RN-F cable, 4G1 mm<sup>2</sup>, (4G1.5 mm<sup>2</sup> for GQGM 6-25), length 10 m.  
Insulation class F.  
Protection IP X8 (for continuous immersion).  
Triple impregnation humidity-proof dry winding  
Constructed in accordance with EN 60034-1, EN 60335-1, EN 60335-2-41.

### Special features on request

Other voltages.  
Frequency 60 Hz (as per 60 Hz data sheet).  
Other mechanical seal.  
Cable length 20 m.  
- Vertical magnetic float switch.  
Three-phase pumps with incorporated float switch.

### Designation

Example: GQGM 6-21  
GQ = Series  
G = Submersible pumps with high power grinder  
M = Single-phase (without three-phase indication)  
6 = Passage of solids Ø mm  
21 = Total head in m indoors

### Materials

Components	Materials
Pump casing	Cast iron GJL 200 EN 1561
Impeller	Cast iron GJL 200 EN 1561
Casing cover	Cast iron GJL 200 EN 1561
Rotating blade	Steel 1.4125 EN 10088 (AISI 440C)
Fixed cutting blade	Steel 1.4125 EN 10088 (AISI 440C)
motor jacket	Chrome-nickel steel 1.4301 EN 10088 (AISI 304)
Jacket cover	Chrome-nickel steel 1.4301 EN 10088 (AISI 304)
Handle	Polypropylene (with frame made of 1.4301 EN 10088 (AISI 304))
Shaft	Chrome-nickel steel 1.4305 EN 10088 (AISI 303)
Upper mechanical seal	Ceramic / Carbon / NBR
Lower mechanical seal	Ceramic / Carbon / NBR
Seal lubrication oil	Oil for food/pharmaceutical machinery

### Coverage chart n ≈ 2900 rpm

#### Three-phase

Model	400V			P2			Q = Flow							
	A	kW	HP	m <sup>3</sup> /h	0	3	6	9	12	13,2	15	16,8		
				l/min										
													H (m) = Total head	
GQG 6-18	2,3	0,9	1,2		18	16,5	14,5	11,2	6,5	4,5	-	-		
GQG 6-21	2,8	1,1	1,5		21	19,2	17	13,5	9	7	4	-		
GQG 6-25	3,8	1,5	2		25	23	20,5	17	13	11	7,8	4		

#### Single-phase

Model	230V		Capacitor		P2		P1	Q = Flow							
	A	Vc	uf	kW	HP	kW		m <sup>3</sup> /h	0	3	6	9	12	13,2	15
							l/min								
													H (m) = Total head		
GQGM 6-18	7	450	30+80	0,9	1,2	1,3		18	16,5	14,5	11,2	6,5	4,5	-	-
GQGM 6-21	7,5	450	30+80	1,1	1,5	1,5		21	19,2	17	13,5	9	7	4	-
GQGM 6-25	9,5	450	30+80	1,5	2	2		25	23	20,5	17	13	11	7,8	4

**P1:** Maximum power input.

**P2:** Rated motor power output.

**ρ:** Density 1000kg/m<sup>3</sup>

**υ:** Kinematic viscosity max 20 mm<sup>2</sup>/sec.

## Dimensions and weights

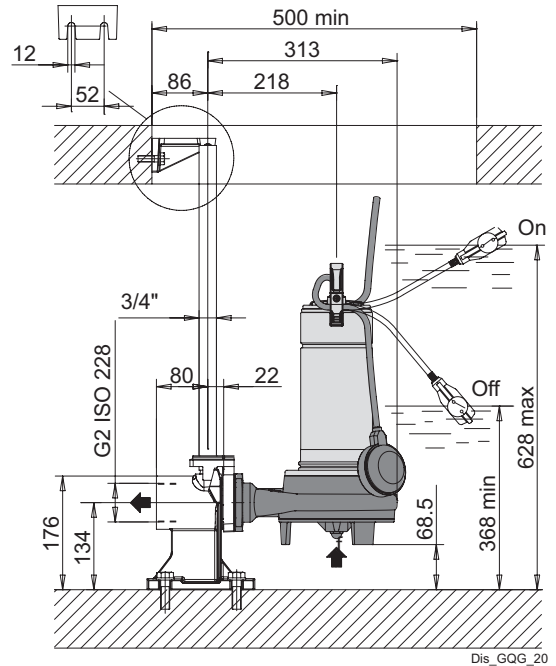
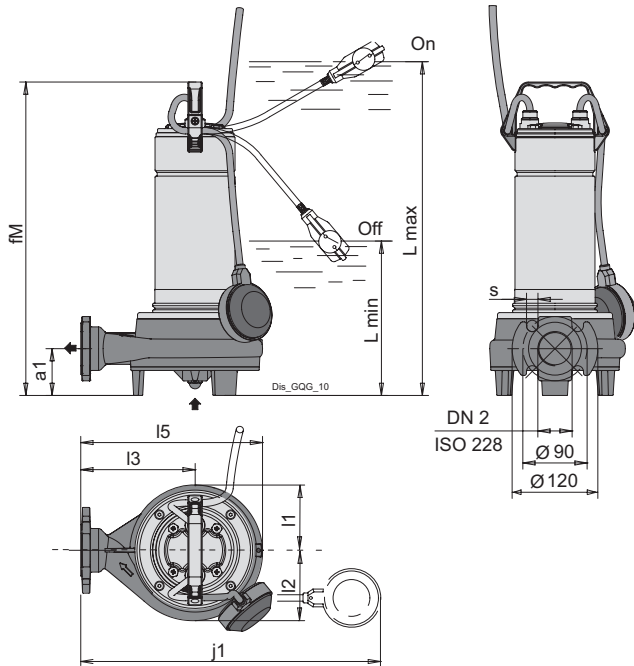

GQGM  
Control with box starting capacitors

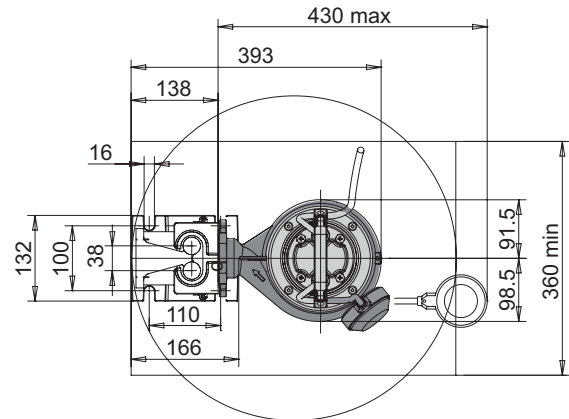
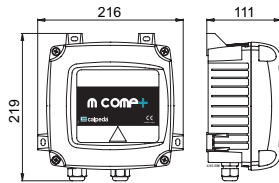

TYPE	ISO 228 DN2	mm							kg Weight
		a1	fM	h2	l1	l2	l5	s	
GQG 6-18	G1 1/2 (DN32)	65	485	160	91	99	255	16	18.4
GQG 6-21	G1 1/2 (DN32)	65	485	160	91	99	255	16	18.6
GQG 6-25	G1 1/2 (DN32)	65	485	160	91	99	255	16	18.7

TYPE	ISO 228 DN2	mm									kg Weight
		a1	fM	h2	l1	l2	l5	Lmax	Lmin	s	
GQGM 6-18	G1 1/2 (DN32)	65	485	160	91	99	255	560	300	16	21.8
GQGM 6-21	G1 1/2 (DN32)	65	485	160	91	99	255	560	300	16	21.8
GQGM 6-25	G1 1/2 (DN32)	65	485	160	91	99	255	560	300	16	22

weights With cable length: 10 m