

# EJ, DJ, EDJ 60 Hz



UNI-EN 12845 fire-fighting systems  
Equipos contra incendios UNI-EN 12845



## EJ 11

UNI-EN 12845 units with 1 N series electric main pump  
Gruppo UNI-EN 12845 con una bomba principal eléctrica N

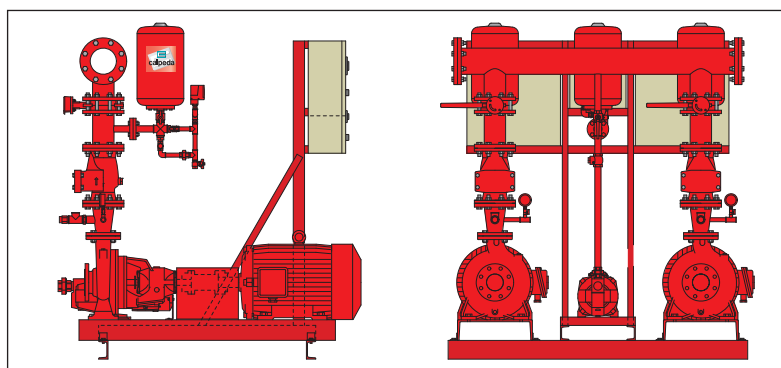

## EJ 21

UNI-EN 12845 units with 2 N series electric main pumps  
Gruppo UNI-EN 12845 con 2 bombas principal eléctricas N

## DJ 11

UNI-EN 12845 units with 1 N series main pump (diesel motor)

Gruppo UNI-EN 12845 con una bomba principal diesel N

## EDJ 21

UNI-EN 12845 units with 2 N series main pumps  
(electric and diesel motors)

Gruppo UNI-EN 12845 con 2 bombas principal N  
(eléctrica + diesel)

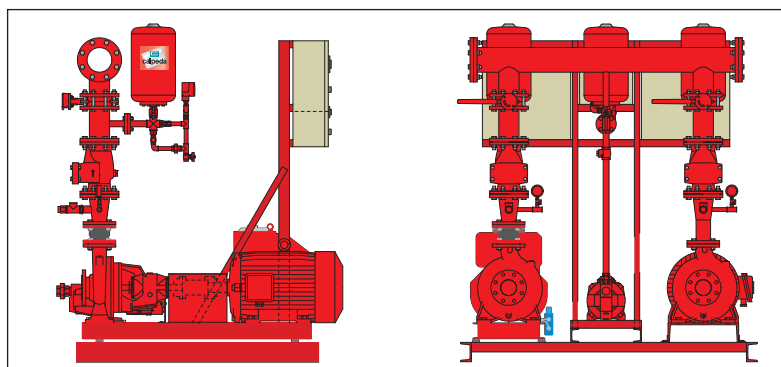

# EJ 60 Hz

EN 12845 units for feeding fire-extinguishing systems  
 Grupo de presión contra incendios según norma EN 12845



With 1 electric pump - Con una bomba principal eléctrica

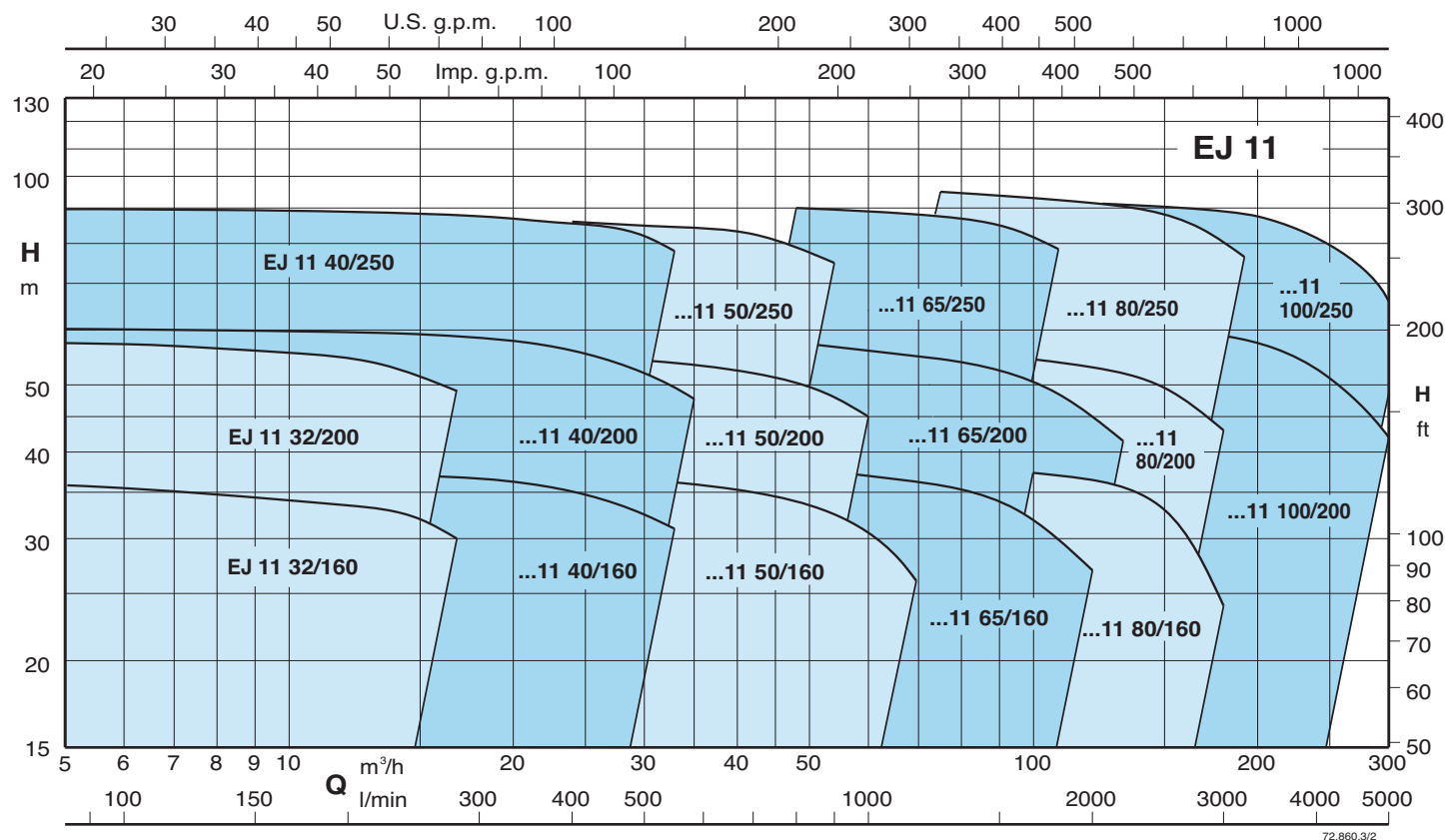

With 2 electric pumps - Con 2 bombas principal eléctricas

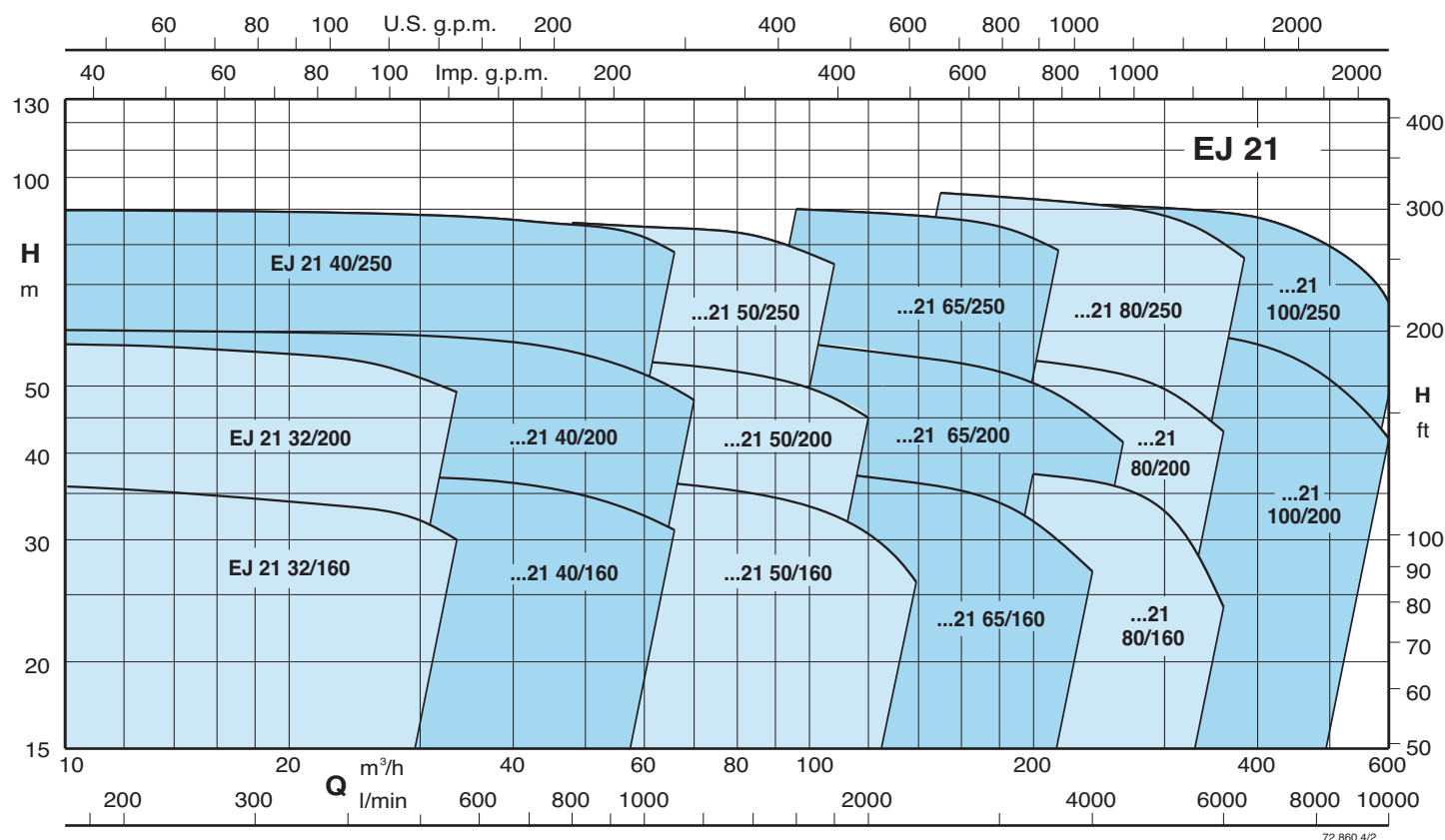

# DJ, EDJ 60 Hz

EN 12845 units for feeding fire-extinguishing systems  
 Grupo de presión contra incendios según norma EN 12845



With 1 diesel pump - Con una bomba principal diesel

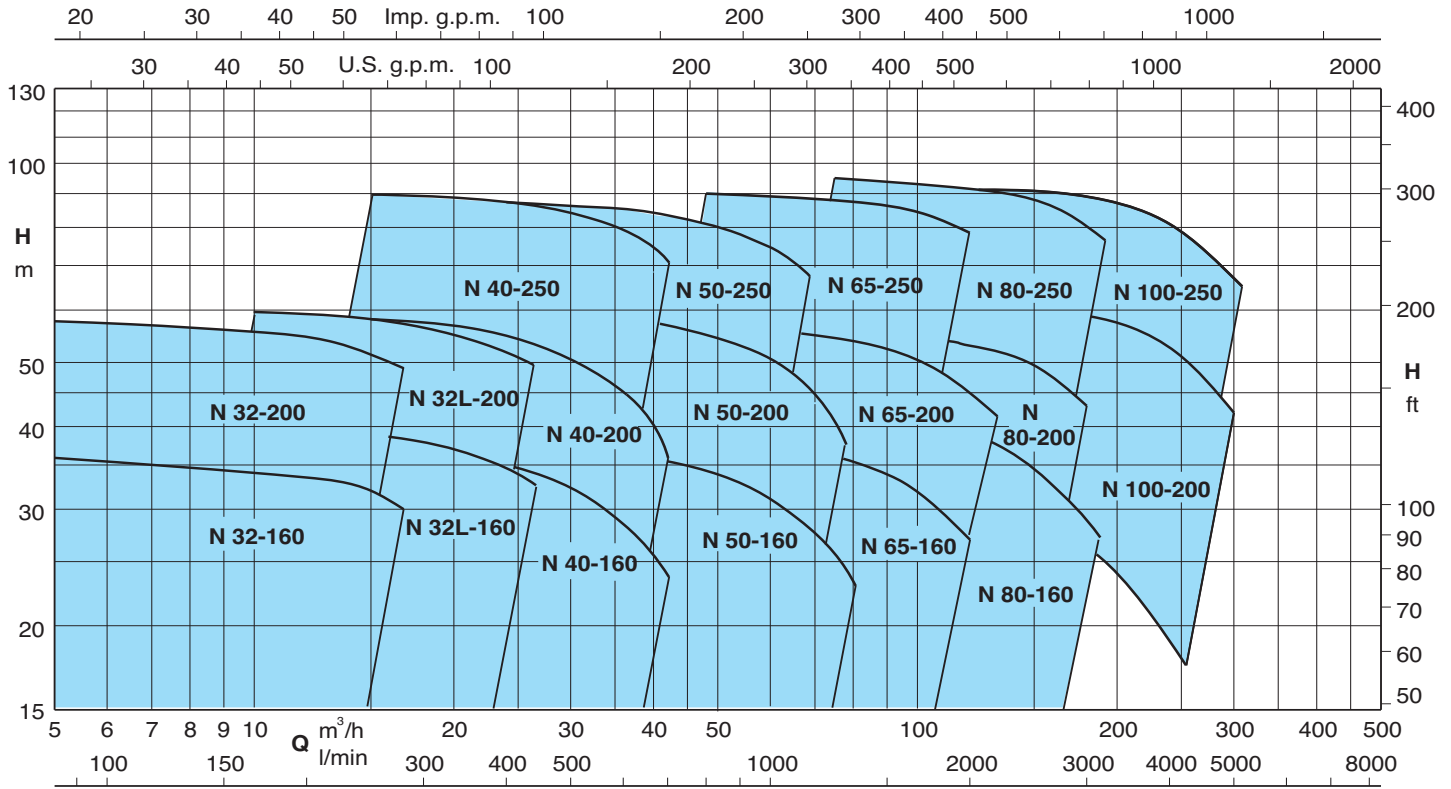

72.844.N

With 2 pumps (electric and diesel) - Con 2 bombas principal (eléctrica + diesel)

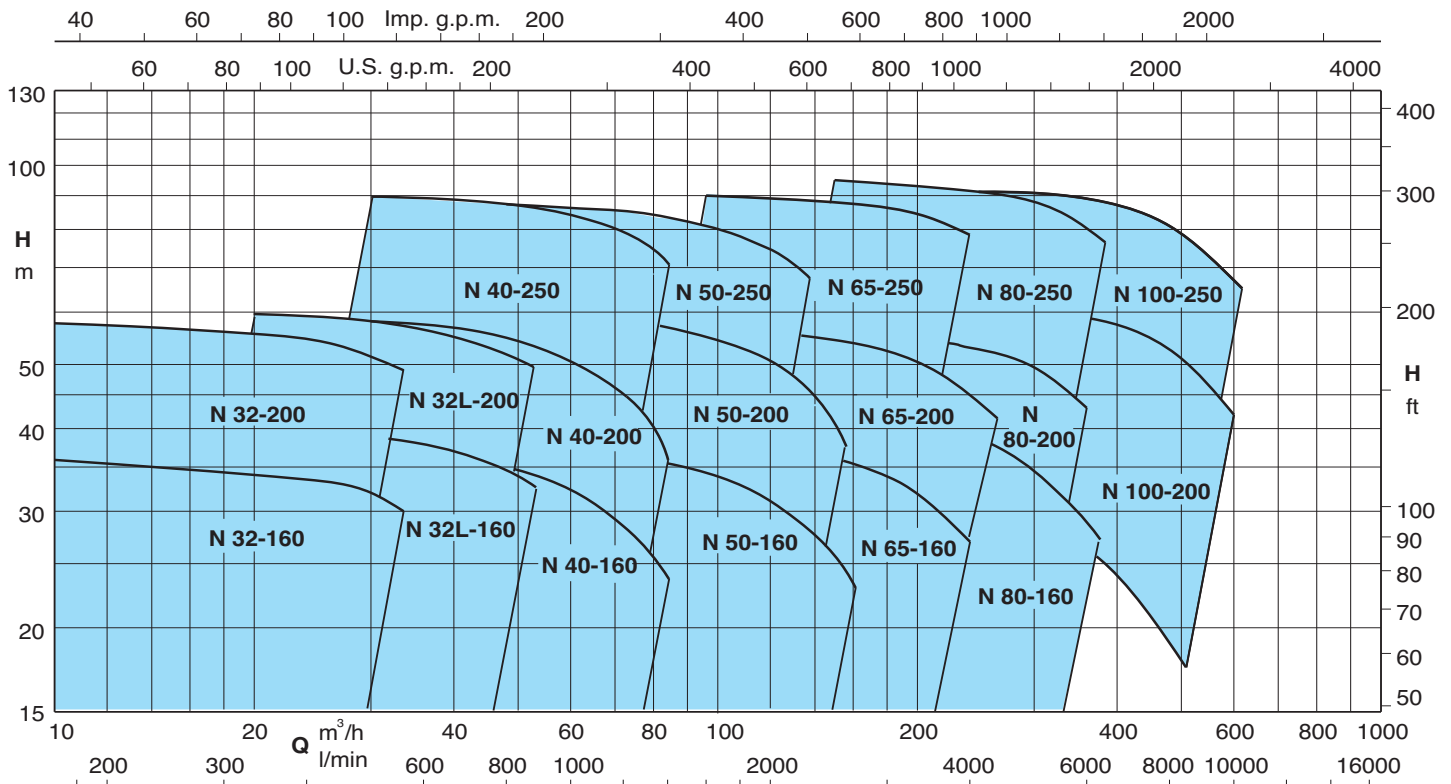

72.844.N



## PMAT 60 Hz

Pressure switches for water system applications  
Presostatos para instalaciones hídricas



### Diagram setting - Curvas Características

