

**Designation**

**BS M 2V 2 MXV 25/204 - I TT**  
**BS M 1V 1F 2 MXV 25/204 - E MT**  
**BS M 2F 2 MXV 25/204**

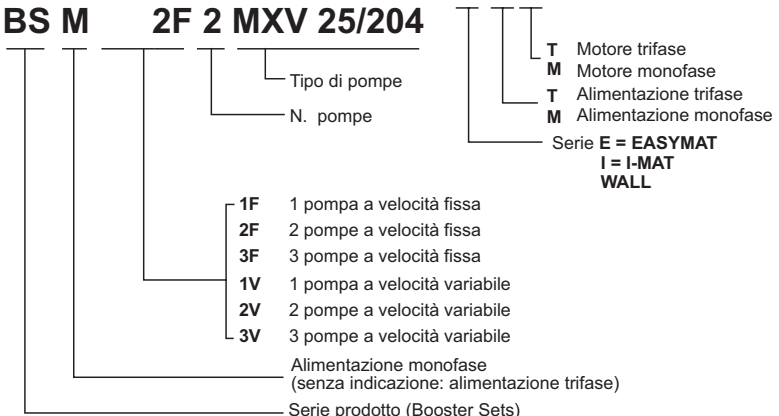

Pressure units with fixed and variable speed pumps



Pressure boosting sets NM, NMD

- BS .F fixed speed 2/3 pumps
- BS .V variable speed with I-MAT 2/3 pumps



Pressure boosting sets MXH

- BS .F fixed speed 2/3 pumps
- BS .V variable speed with EASYMAT 1/3 pumps
- BS .V variable with EASYMAT2 2 pumps
- BS .V variable with WALL 2 pumps
- BS .V variable speed with I-MAT 2/3 pumps



Pressure boosting sets MPSU

- BS .F fixed speed 2/3 pumps
- BS .V variable speed with EASYMAT 1/3 pumps

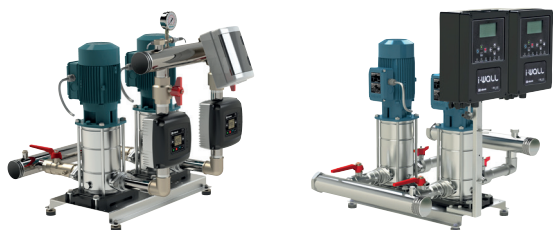

Pressure boosting sets MXVB

- BS .V variable speed with EASYMAT 1/3 pumps
- BS .V variable with EASYMAT2 2 pumps
- BS .V variable with WALL 2 pumps



Pressure boosting sets MXV

- BS .F fixed speed 1/3 pumps
- BS .V variable with WALL 2 pumps
- BS .V variable with I-MAT 2/3 pumps

TO SELECT A PRESSURE BOOSTING SET

**BSF**

2 and 3 fixed speed pumps

**Construction**

Pressure boosting sets with automatic operation, consisting in 2 and 3 pumps on a common baseplate, with suction and delivery manifolds, gate and non-return valves, pressure switches, pressure gauge, control panel and

**Functioning mode**

The control panel, with electronic card, manages the pump operation, the changeover of pump starting sequence and it stops the system when there is no air in the tank (patented system). Pumps starting in a cascade sequence, with a signal from the pressure switches.

**BS 2F**  
2 pompe a velocità fissa

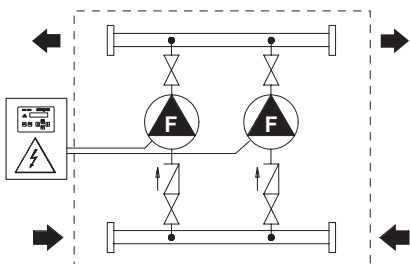

**BS 3F**  
3 pompe a velocità fissa

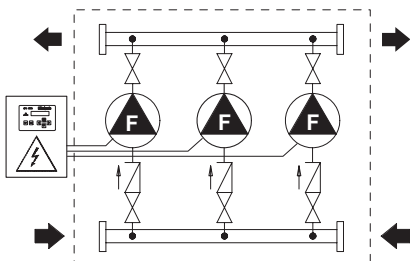

**BS 2F**  
2 pompe a velocità fissa

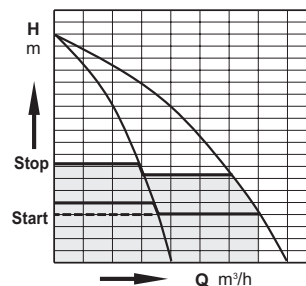

**BS 3F**  
3 pompe a velocità fissa

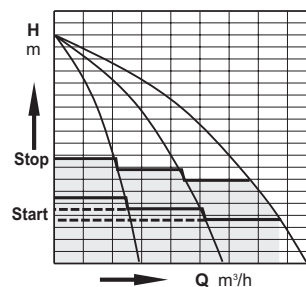

**BSV**  
2-6 variable speed pumps (with frequency converter)

**Construction**

Pressure boosting sets with automatic operation, consisting of variable speed pumps (from 1 to 6) with frequency converter, assembled on a common baseplate, with suction and delivery manifolds,

**Functioning mode**

The control panel, with electronic card, manages the pump operation, the changeover of pumps starting sequence.

Pumps starting is in a cascade sequence, with a signal from the pressure transducer.

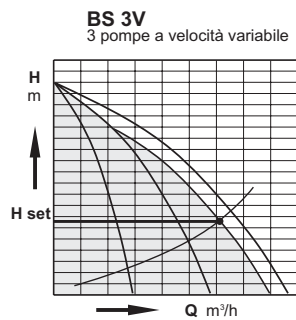
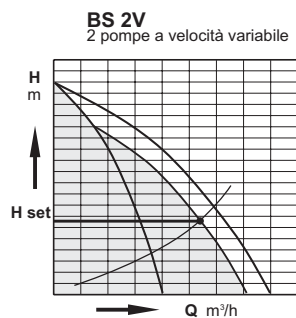
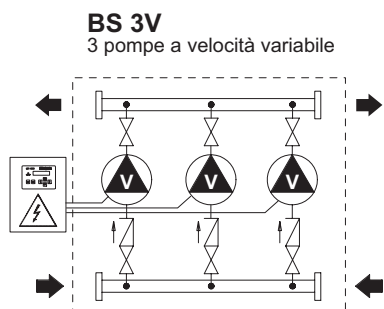
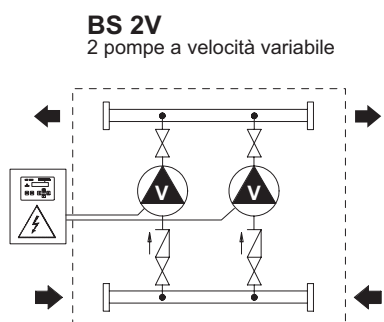



## Fixed speed pump units

### Fixed speed pump units New electrical control panels

New electrical control panels for pressurisation units, all with electronic card with microprocessors, for managing pump operation.

The microprocessor carries out continuous secure checks during all the various work phases of the pumps and incorporates all necessary functions, thus reducing electrical and electronic components inside the panel.

#### In particular:

- - pumps starting in a cascade sequence according to water demand.
- - changeover of pump starting sequence.
- - delay start-up of the 2nd/3rd pump in case of breakdown of pressure switch 1 or after a power cut.
- - avoid pump starting in case of water hammering.
- - activate the alarm when pressure 1 fails.
- - activate the alarm when air cushion in the vessel drops.
- - stop the pump when air cushion is over.

#### Maximum clarity for all signals

The status of the unit can easily be identified on the front of the electronic card with the following signals:

- - Power on.
- - No water.
- - Failure.
- - Pump running.
- - Thermal block.
- - Pump automatic operation.
- - Pump stop.

#### Maximum simplicity of control

The front of electronic card features the following signals and controls:

- - AUT-STOP push-button (1 for each pump)
- - MAN push-button (1 for each pump)
- - RESET push-button.

#### Optional remote control

The RA 100 panel enables a remote warning light and acoustic signal.

#### Control panel for units up to 6 pumps

Using the MPS 6000 (Multi Pumps System) electronic card it is possible to control pressure units up to a maximum of 6 fixed speed pumps with a single pressure calibration.

#### Automatic air supply systems

The pump control panels are completed by microprocessor controlled systems for automatic air supply in the pressure vessels by means of a compressor or solenoid valve. Operation

#### Functioning mode

For booster sets made up to three pumps: according to the pressure decrease in the system, the pressure switches (pressure transducer for 3-pump sets) make the pumps to start in cascade mode and the starting changeover is made by the microprocessor.

For sets made of 4, 5, 6 pumps: Operation controlled by a microprocessor with signal from a pressure transducer. The pumps operate with only one pressure setting. The pumps operate with only one pressure setting.



## Variable speed pump units with EASYMAT

### EASYMAT for variable speed pump units.

Variable speed system driven by frequency converter, for the pressure control in domestic and residential plants.

The system maintains constant pressure whilst the controlling the pump operation against changing system demand.

### Maximum clarity for all signals

Easymat is equipped with a control panel for simple system programming and parameter monitoring.

2 scroll buttons are used to scroll the different operating parameters that EASYMAT can show.

At the same time you can use the 2 scroll buttons to move in the set up menu and to change the different options.

The LCD custom display gives an easy overview of the system situation and of the operating parameters.

The icons on the top and below the display area explain in which way EASYMAT is working and if there are problems on the system.

The four set-up buttons allow the operator to move between and set-up the menu's and to start and stop the pump. The symbols help to make the function of each button clear.

With these 4 buttons and the 2 scroll buttons you can manage all the set-up and operating parameters without the use of an other control panel or computer.

### Functioning mode

Depending on water consumption, one or more pumps are activated, all at variable speed, in order to guarantee the quantity of water required at the set pressure.

The system is connected to the delivery pipe providing for simple installation and better cooling (patented) making the unit more compact and easy to assemble.

Easymat is supplied with one pressure transducer, G 1/4 connection and 1.5 m cable length.

### For protection of the pump:

- Against dry running
- – Against operations with closed connection ports
- – Against overcurrent of the motor
- – Against overvoltage and undervoltage of the power supply

### Silent operation

Motors working at reduced speed and check valves that close gradually mean that operation is particularly quite.

### Long life for pumps

All the mechanical components of the pumps and motors are stressed to a minimum, due to the variable speed operation.

### Energy saving

The motors consume only the precise level of power necessary moment to moment, in order to supply the quantity of water required by the system.

### No more high capacity vessels

The use of inverters means that high capacity pressure vessels and membrane vessels are no longer necessary. Even units with high flowrate pumps only require a small number of 20 litre membrane vessels.



### Constant pressure mode

The system keeps the pressure constant when the quantity of water requested by the user changes. The user can choose the operating pressure according his needs.



### Fixed speed mode

The system works at a fixed speed that user can choose according his needs.



## Variable speed pump units with EASYMAT4

### EASYMAT2 for variable speed pump units.

Variable speed system driven by frequency converter, for the pressure control in domestic and residential plants.

The system maintains constant pressure whilst the controlling the pump operation against changing system demand.

### Maximum clarity for all signals

Easymat2 is equipped with a control panel for simple system programming and parameter monitoring.

2 scroll buttons are used to scroll the different operating parameters that EASYMAT can show.

At the same time you can use the 2 scroll buttons to move in the set up menu and to change the different options.

The LCD custom display gives an easy overview of the system situation and of the operating parameters.

The icons on the top and below the display area explain in which way EASYMAT2 is working and if there are problems on the system.

### Functioning mode

Depending on water consumption, one or more pumps are activated, all at variable speed, in order to guarantee the quantity of water required at the set pressure.

### For protection of the pump:

- Against dry running
- – Against overcurrent of the motor
- – Against overvoltage and undervoltage of the power supply

### Silent operation

Motors working at reduced speed and check valves that close gradually mean that operation is particularly quite.

### Long life for pumps

All the mechanical components of the pumps and motors are stressed to a minimum, due to the variable speed operation.

### Energy saving

The motors consume only the precise level of power necessary moment to moment, in order to supply the quantity of water required by the system.

### No more high capacity vessels

The use of inverters means that high capacity pressure vessels and membrane vessels are no longer necessary. Even units with high flowrate pumps only require a small number of 20 litre membrane vessels.



### Constant pressure mode

The system keeps the pressure constant when the quantity of water requested by the user changes. The user can choose the operating pressure according to his needs.



### Fixed speed mode

The system works at a fixed speed that user can choose according to his needs.

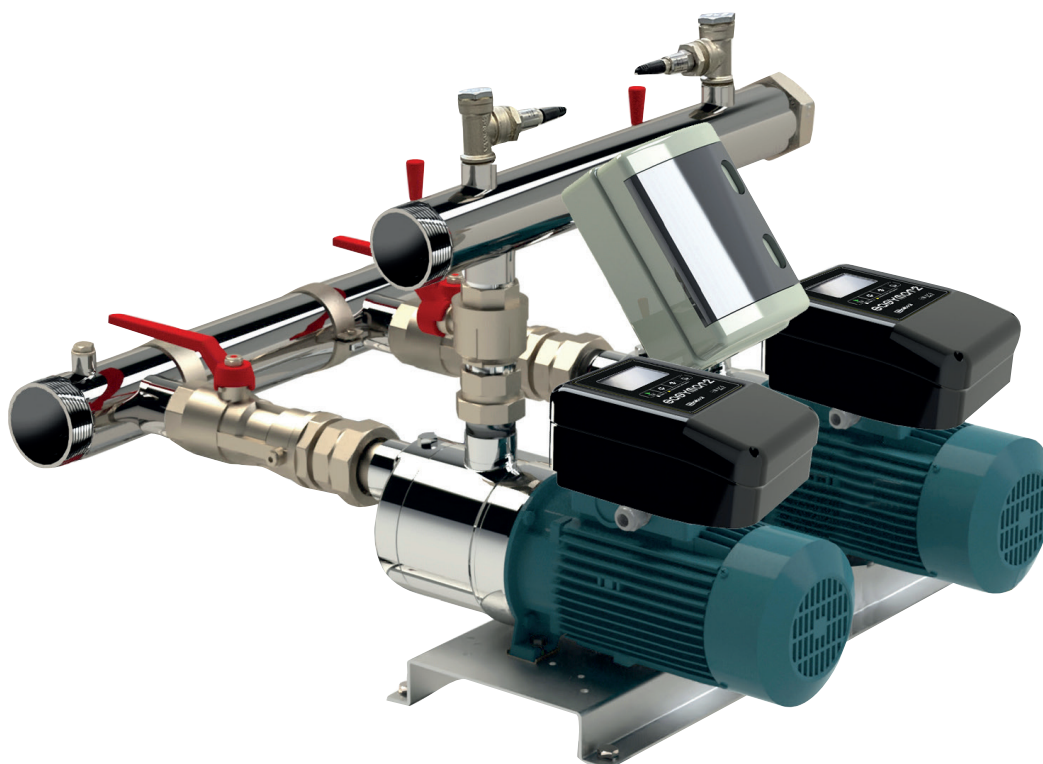

## Variable speed pump units with WALL

### WALL for variable speed pump units.

Variable speed system driven by frequency converter, for the pressure control in domestic and residential plants.

The system maintains constant pressure whilst the controlling the pump operation against changing system demand.

### Maximum clarity of signals

WALL is equipped with a control panel that allows to carry out the set-up of the system and to monitor all system parameters.

The 4 set-up buttons are created to enter and to move on the set-up menus and to start and to stop the pump. The symbols help to understand the function of each button. With these 4 buttons and the 2 scroll buttons you can manage all the set-up

### For protection of the pump:

- Against dry running
- – Against overcurrent of the motor
- – Against overvoltage and undervoltage of the power supply

### Functioning mode

Depending on water consumption, one or more pumps are activated, all at variable speed, in order to guarantee the quantity of water required at the set pressure.

### Silent operation

Motors working at reduced speed and check valves that close gradually mean that operation is particularly quite.

### Long life for pumps

All the mechanical components of the pumps and motors are stressed to a minimum, due to the variable speed operation.

### Energy saving

The motors consume only the precise level of power necessary moment to moment, in order to supply the quantity of water required by the system.

### No more high capacity vessels

The use of inverters means that high capacity pressure vessels and membrane vessels are no longer necessary. Even units with high flowrate pumps only require a small number of 20 litre membrane vessels.



### Constant pressure mode

The system keeps the pressure constant when the quantity of water requested by the user changes. The user can choose the operating pressure according his needs.



### Fixed speed mode

In this operating mode the system work as a fixed speed pump. The speed of the pump could be set by the user between a range of speeds, or controlled by an external signal.



## Variable speed pump units with I-MAT

### I-MAT for variable speed pump units.

Variable speed system driven by frequency converter, for the pressure control in domestic and residential plants.

The system maintains constant pressure whilst the controlling the pump operation against changing system demand.

### Maximum clarity of signals

I-MAT is equipped with a control panel that allows to carry out the set-up of the system and to monitor all system parameters.

It is possible use the control panel in remote positions by means a cable with M12 connectors (standard cable).

The LCD custom display gives an easy overview of the system situation and of the operating parameters.

The 4 set-up buttons are created to enter and to move on the set-up menus and to start and to stop the pump. The symbols help to understand the function of each button. With these 4 buttons and the 4 scroll buttons you can manage all the set-up

### For protection of the pump:

- Against dry running
- – Against operations with closed connection ports
- – Against overcurrent of the motor
- – Against overvoltage and undervoltage of the power supply
- Against overvoltage and undervoltage of the power supply

### Functioning mode

Depending on water consumption, one or more pumps are activated, all at variable speed, in order to guarantee the quantity of water required at the set pressure.

### Silent operation

Motors working at reduced speed and check valves that close gradually mean that operation is particularly quite.

### Long life for pumps

All the mechanical components of the pumps and motors are stressed to a minimum, due to the variable speed operation.

### Energy saving

The motors consume only the precise level of power necessary moment to moment, in order to supply the quantity of water required by the system.

### No more high capacity vessels

The use of inverters means that high capacity pressure vessels and membrane vessels are no longer necessary. Even units with high flowrate pumps only require a small number of 20 litre membrane vessels.

### Constant pressure mode

The system keeps the pressure constant when the quantity of water requested by the user changes. The user can choose the operating pressure according his needs.



### Proportional pressure modes

Proportional pressure reduces the pressure of the pump (and as a consequence, the operating frequency) proportionally with the water demand of the system.



### Constant temperature mode

In this operating mode the system is used to keep the temperature at a constant value in a specified system point.



### Constant flow mode

Constant flow mode grants that system change the speed of the pump in order to keep constant the flow which pass inside a flow meter.



### Fixed speed mode

In this operating mode the system work as a fixed speed pump. The speed of the pump could be set by the user between a range of speeds, or controlled by an external signal.



### Night mode

The night mode is an optional mode which allows to reduce the speed of the pump if the temperature in the system decreases below a set value, this operating mode can be used with all operating modes over described.

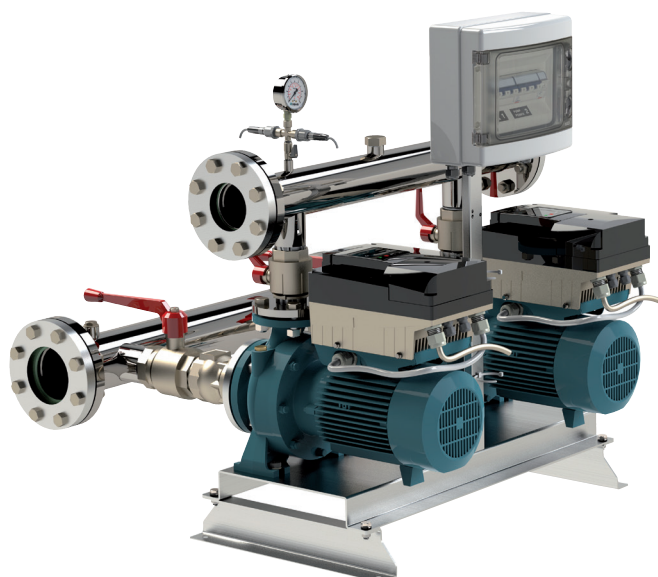



# BS, NM, NMD



Pressure units with 1 to 3 fixed or variable speed centrifugal pumps (INVERTER)

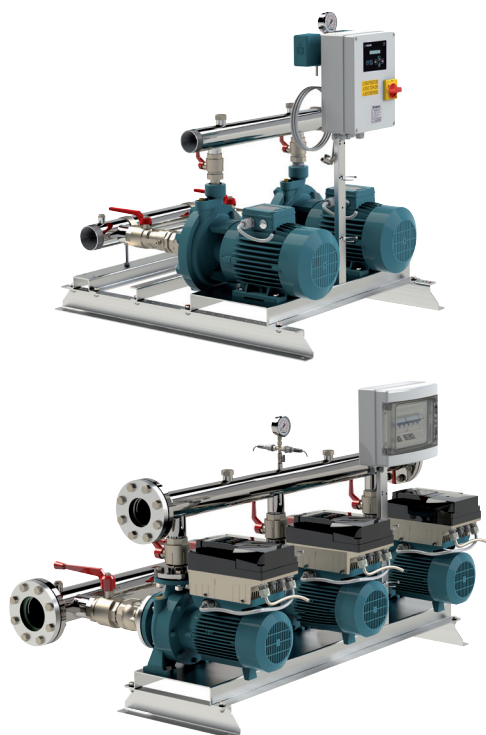

## Fixed speed units

BS 2-6F Units with 2 to 6 fixed speed pumps

Sets with 4,5 and 6 pumps on request.

Depending on the reduction of the pressure in the system, the pressure switches (pressure transducer for 3-pump sets) determine the starting up of the pumps in sequence and the microprocessor alternates the starts.

## Variable speed units with I-MAT

BS2-3V Pressure boosting sets with 2 to 3 variable speed pumps (with I-MAT).

Depending on water consumption, one or more pumps are activated, all at variable speed, in order to guarantee the quantity of water required at the set pressure.

## Coverage chart

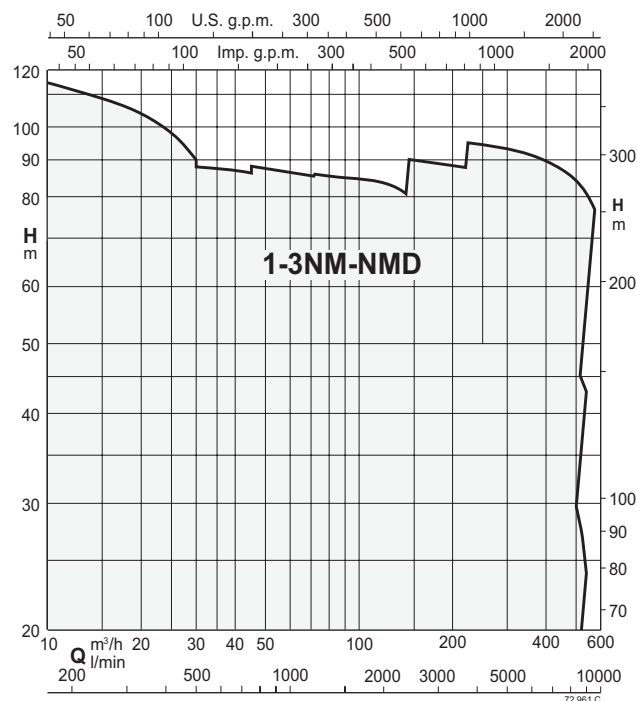

## Construction

Automatic pressure boosting plant consisting of 1 to 6 centrifugal pumps complete with ball, non return valve on the suction side and ball valves on the delivery side.

Suction and delivery manifolds for boosting

- stainless steel AISI 304 up to 2NM 40.. and 3NM 32...
- - steel S235JR from 2NM 50.. and 3NM 40... .

Set up for mounting cylindrical tanks with G1 connection.

Electrical control boards:

- with microprocessor for fixed speed pump units. Motor starting is D.O.L. up to 5,5 kW and Y/Δ for power rating 7,5 up to 55 kW.
- - with frequency converter for variable speed pump units.

The unit includes one pressure gauge and three adjustable differential pressure switches or pressure transducer.

## Applications

To supply water in civil and industrial buildings.

For increasing network pressure (follow local specifications).

## Motor

2-pole induction motors, 50 Hz,  $n \approx 2900$  1/min, set up for inverter operation.

Three-phase: 230/400V  $\pm 10\%$  up to 3 kW;  
400/690V  $\pm 10\%$  for 4 kW to 55 kW;

Insulation class F.

Protection IP54

Constructed in accordance with: IEC 60034.

Other voltages and frequencies on request.

## Vessels on request

When installing the unit, connect in the delivery section to a diaphragm or galvanised tank.

The recommended sized are shown in the following page.

## Special features on request

Pressure unit with 4, 5 and 6 pumps

Characteristic curves

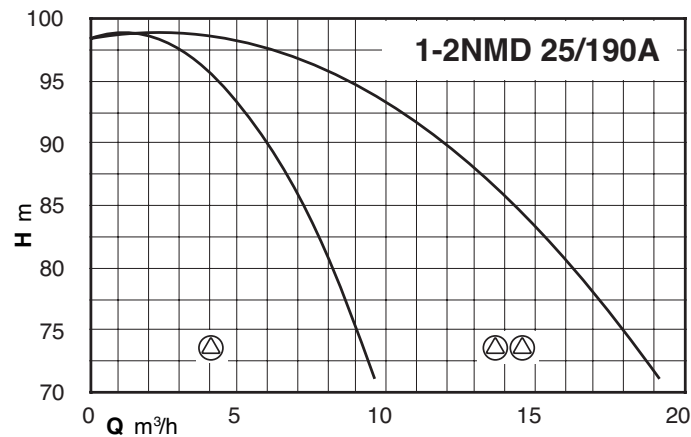
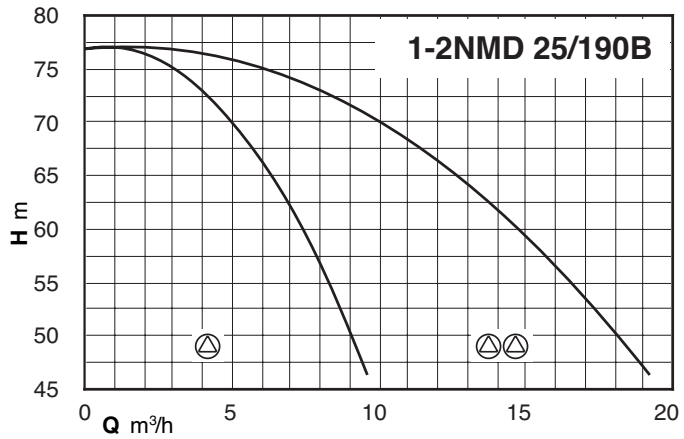
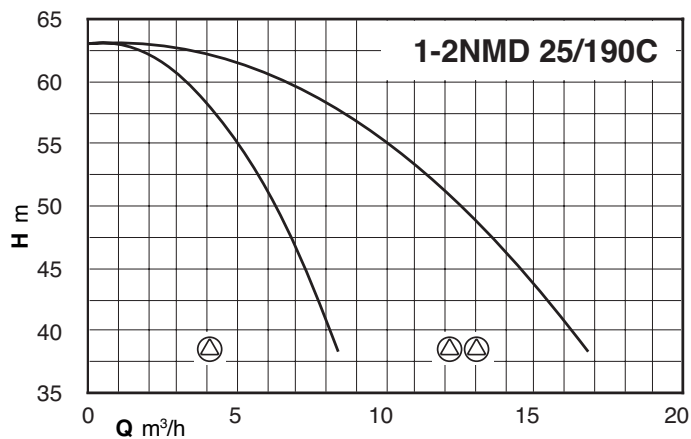
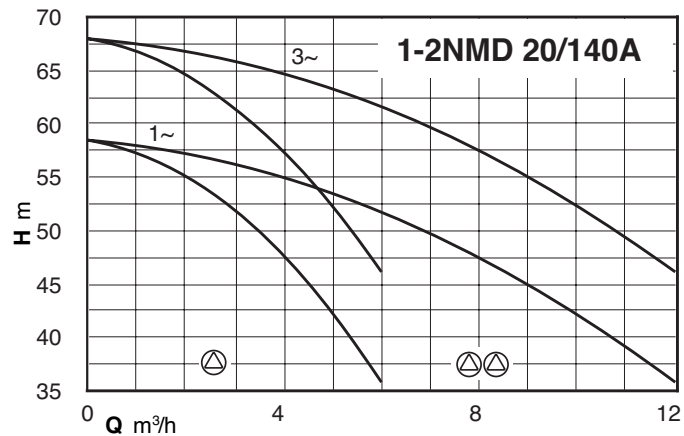
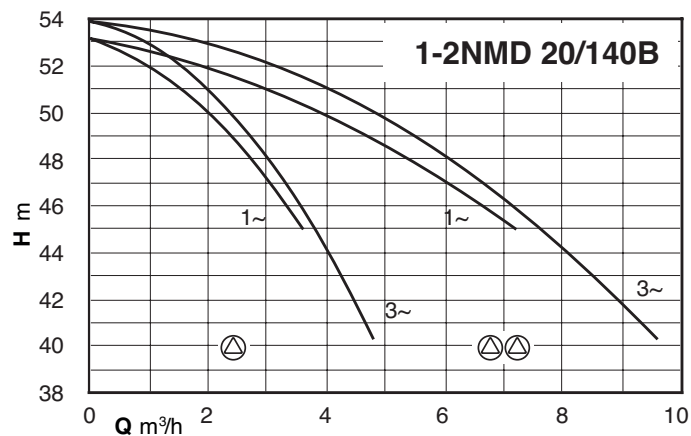
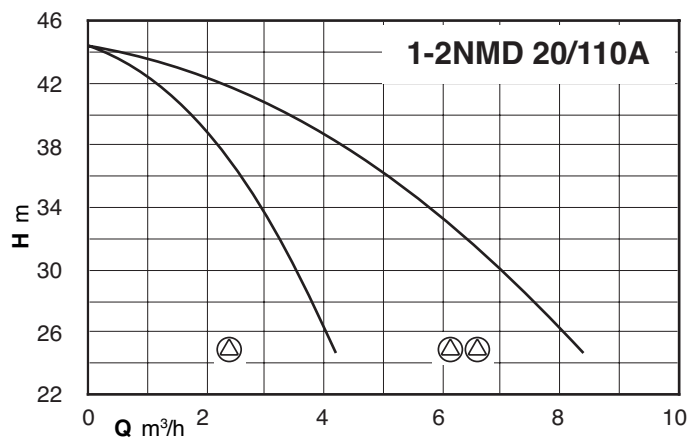
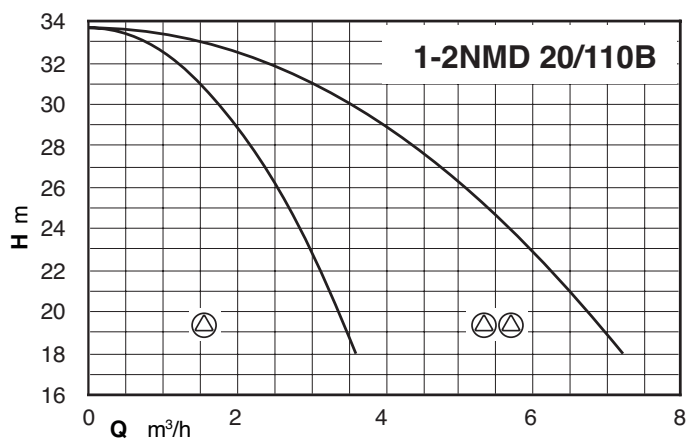

## Characteristic curves

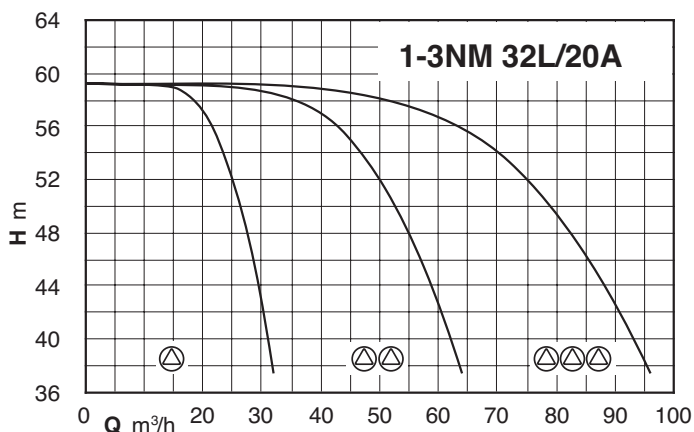
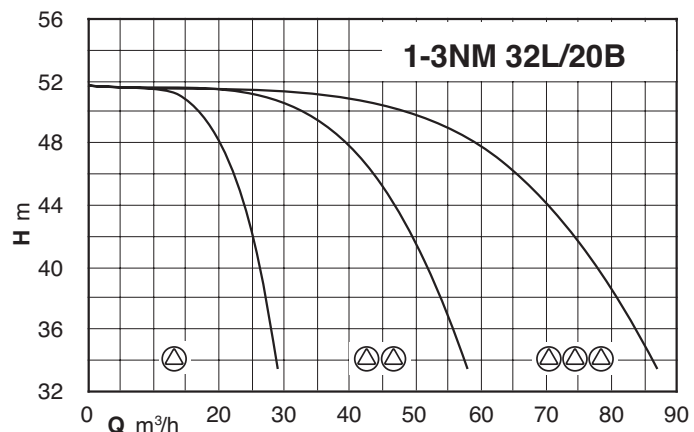
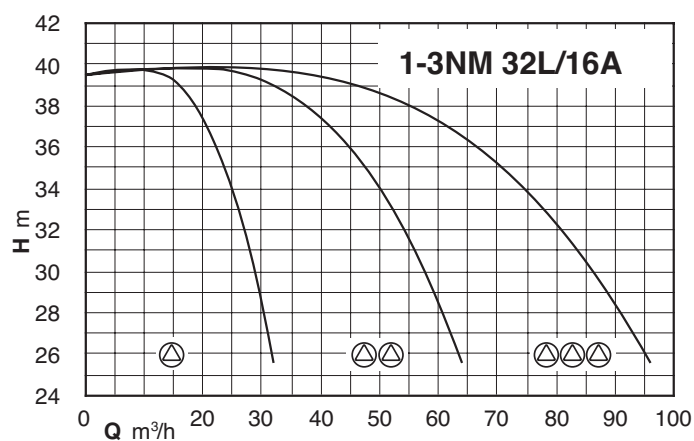
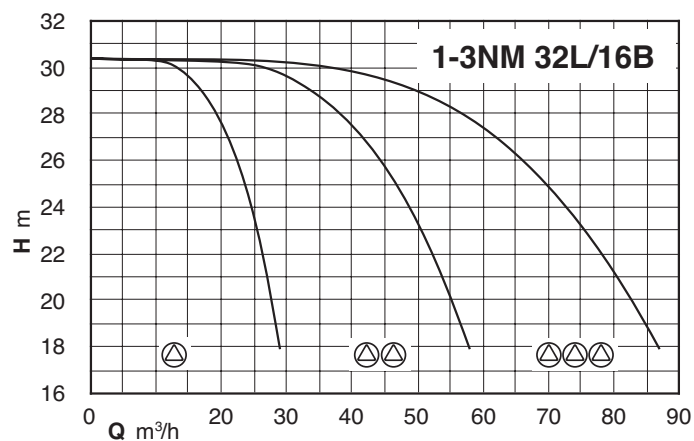
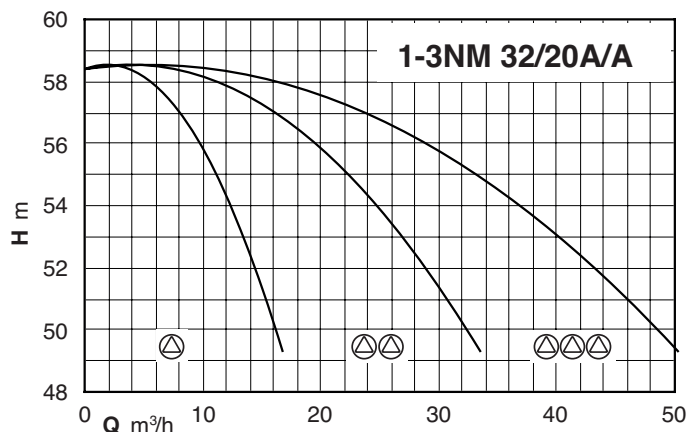
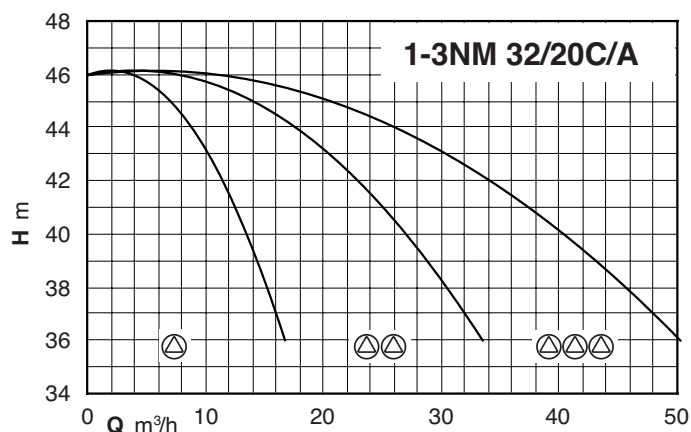
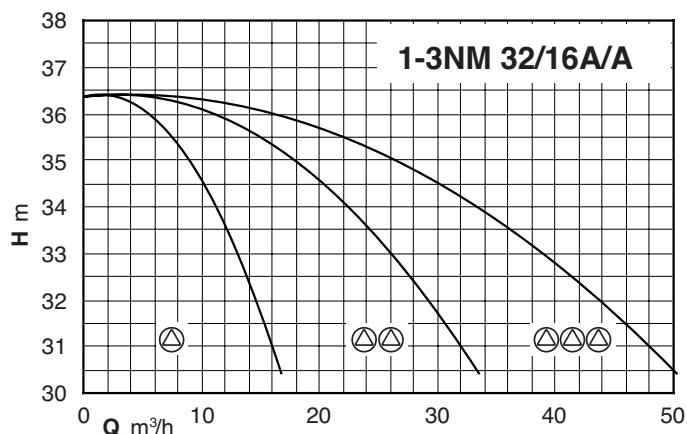
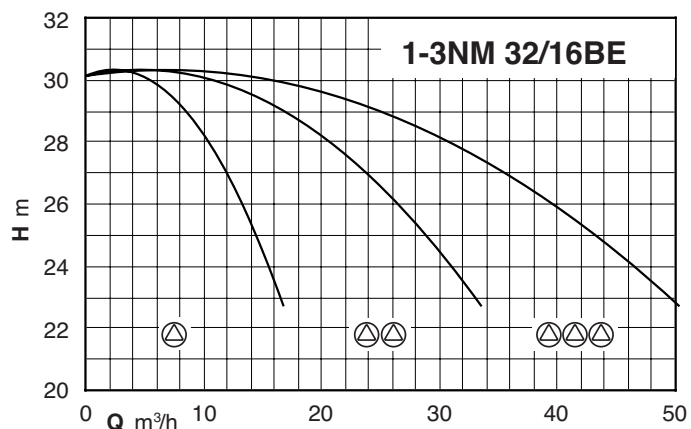



Characteristic curves

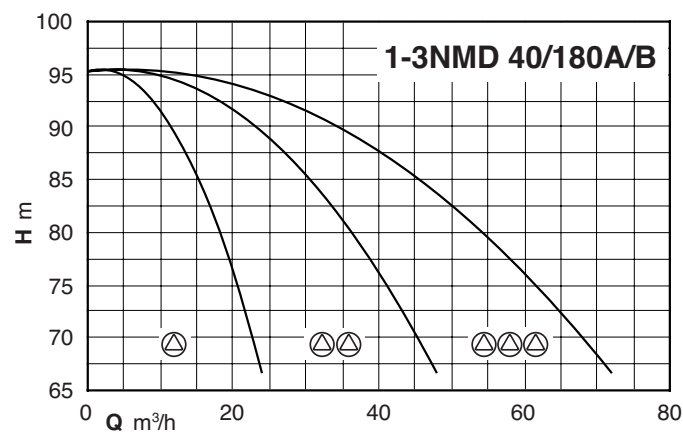
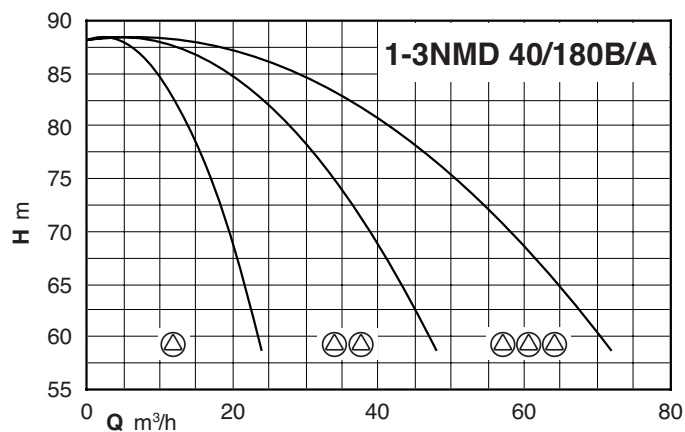
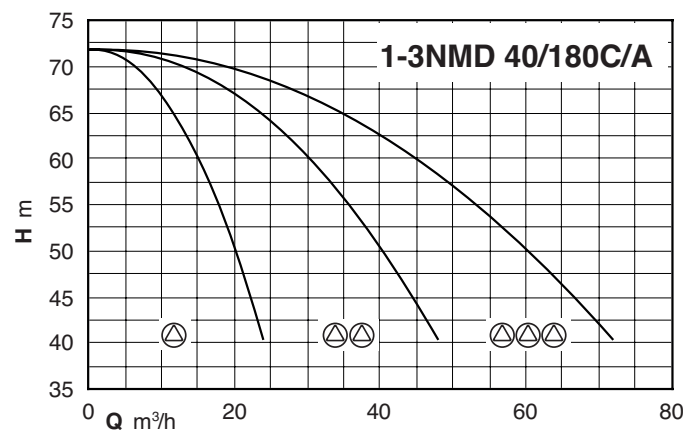
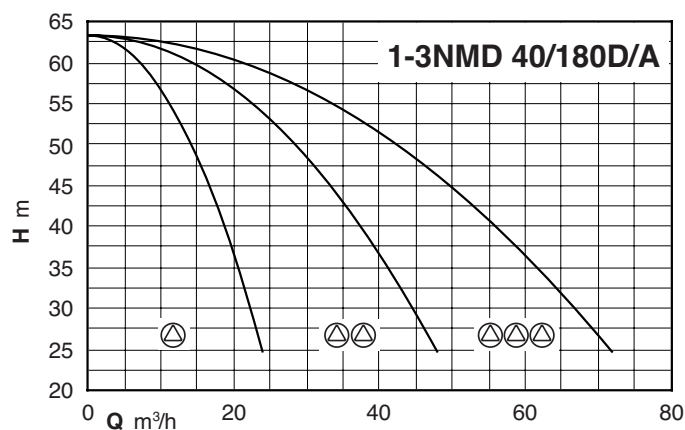
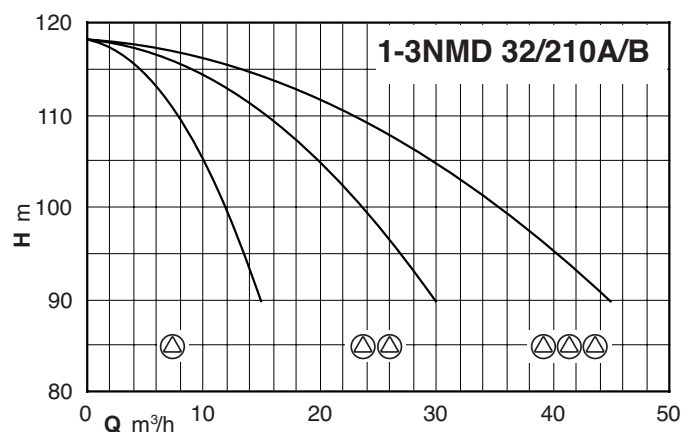
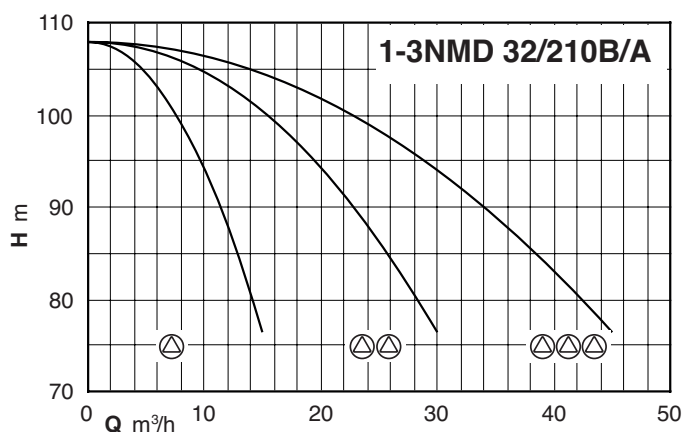
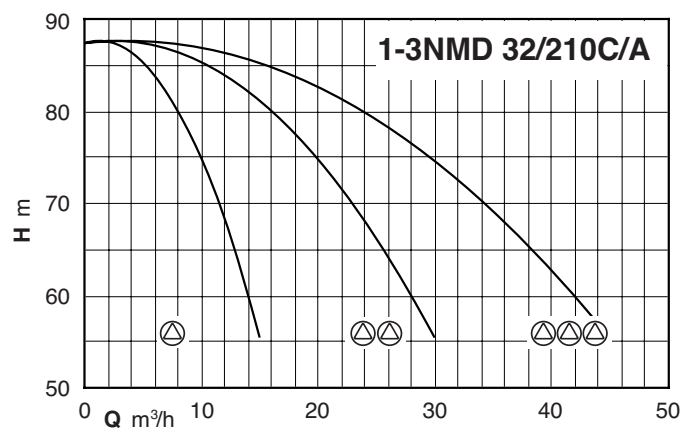
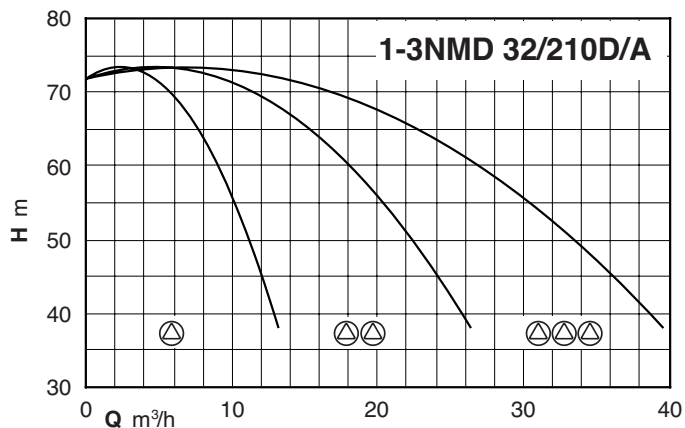

## Characteristic curves

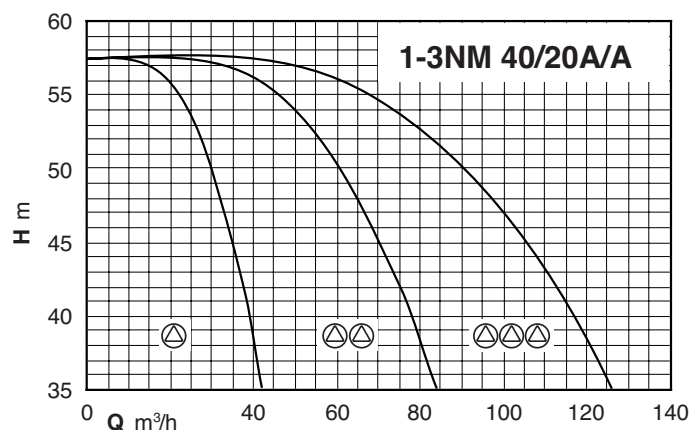
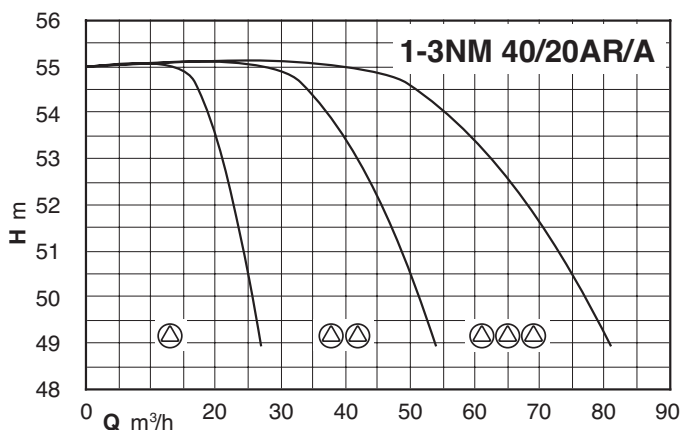
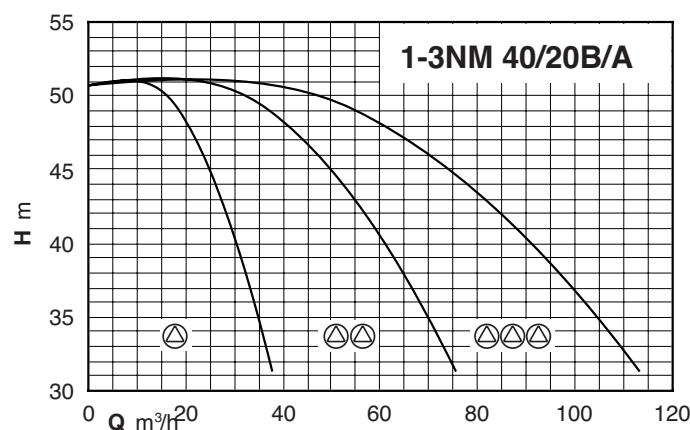
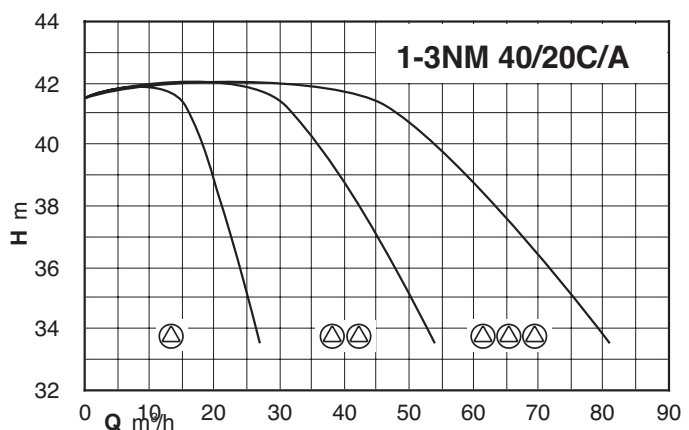
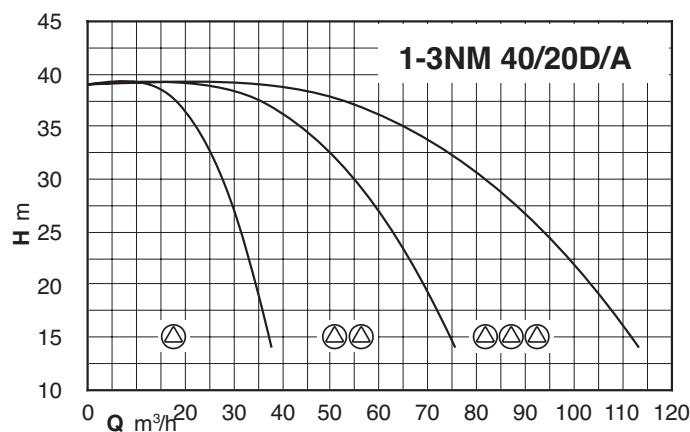
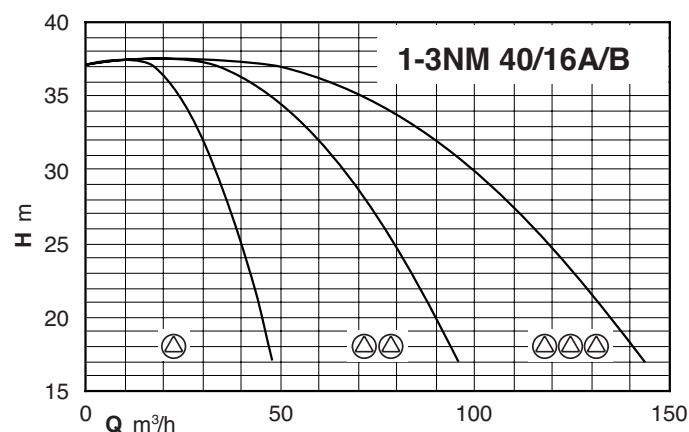
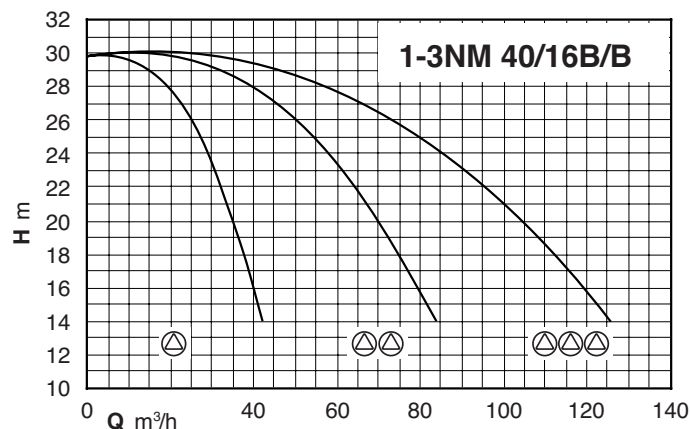
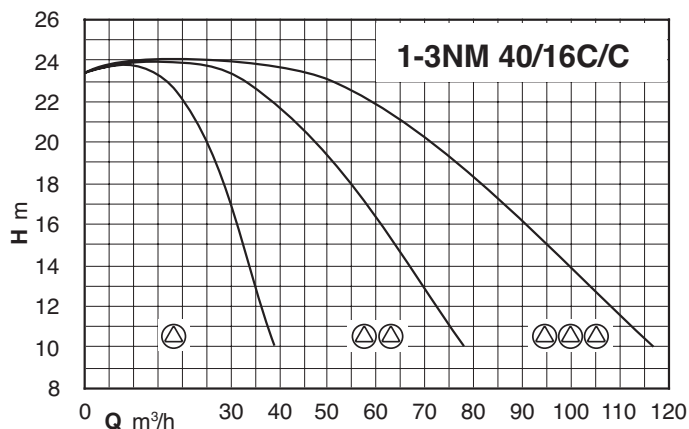

Characteristic curves

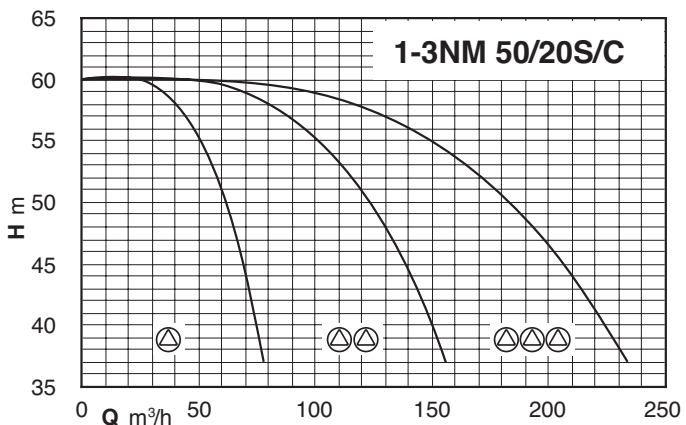
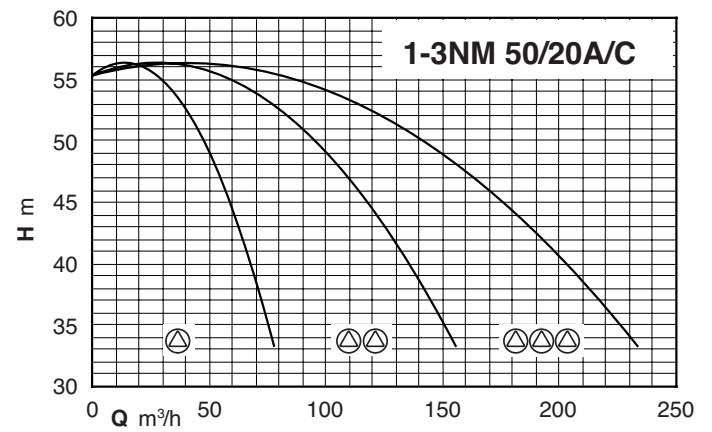
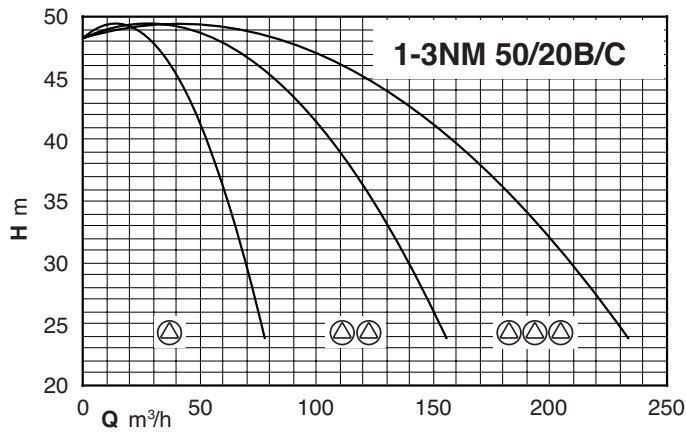
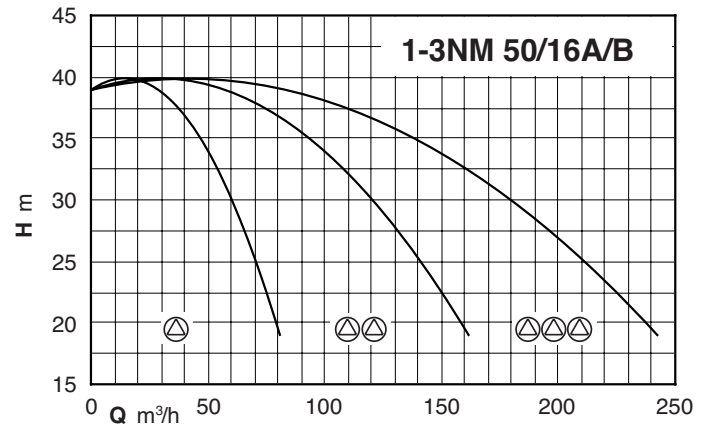
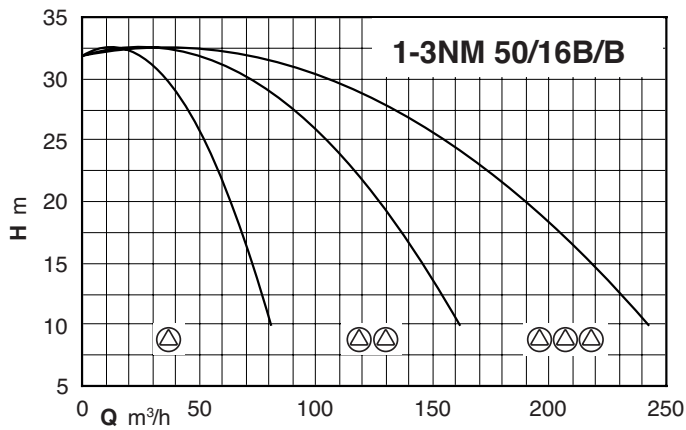
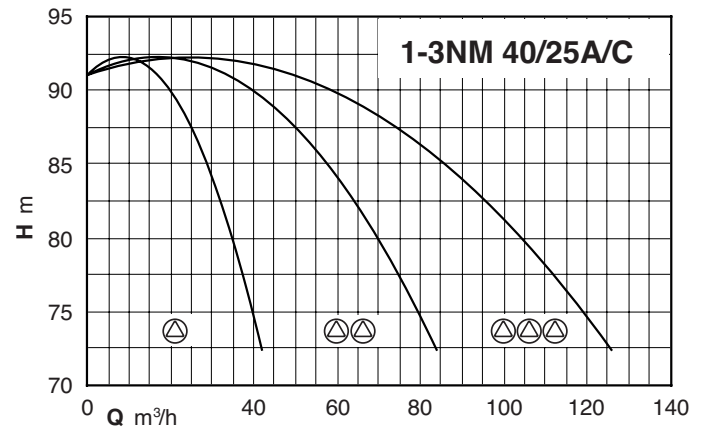
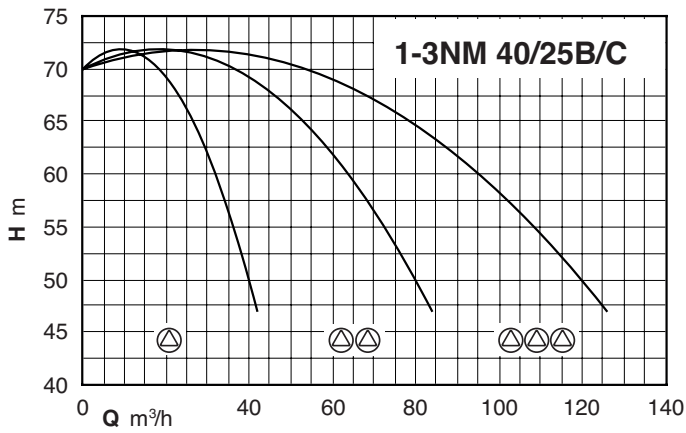

## Characteristic curves

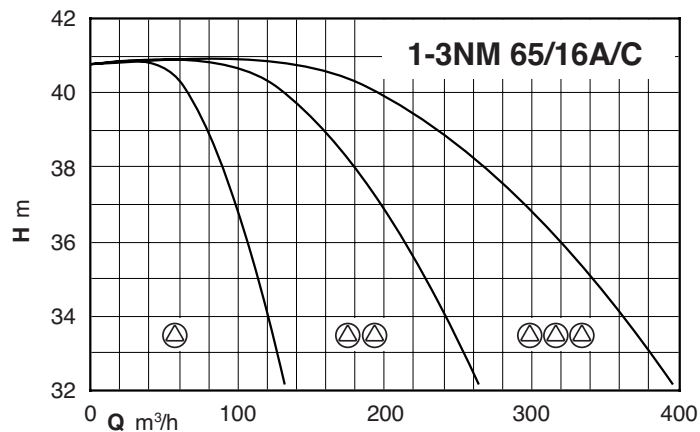
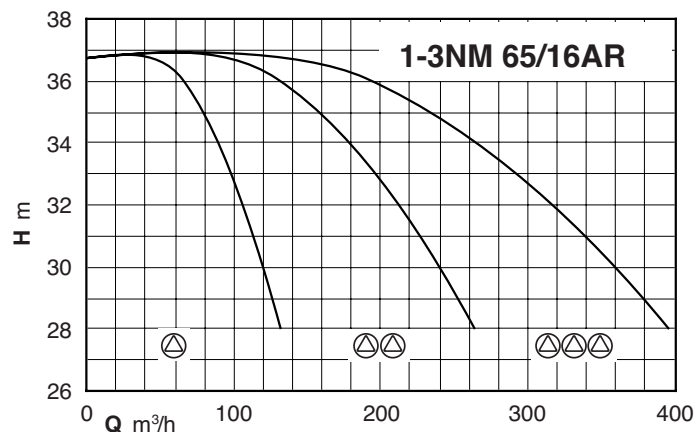
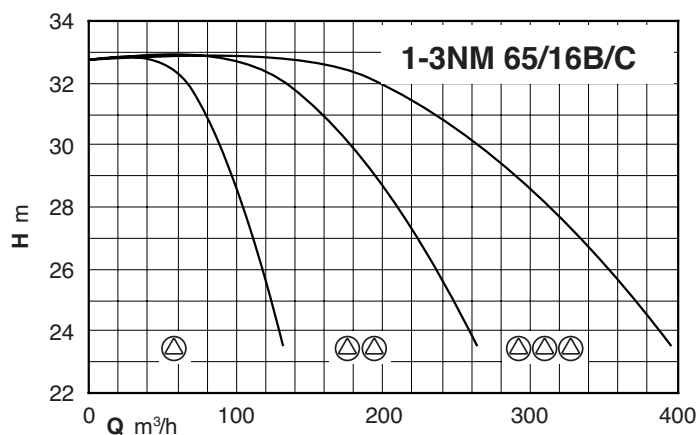
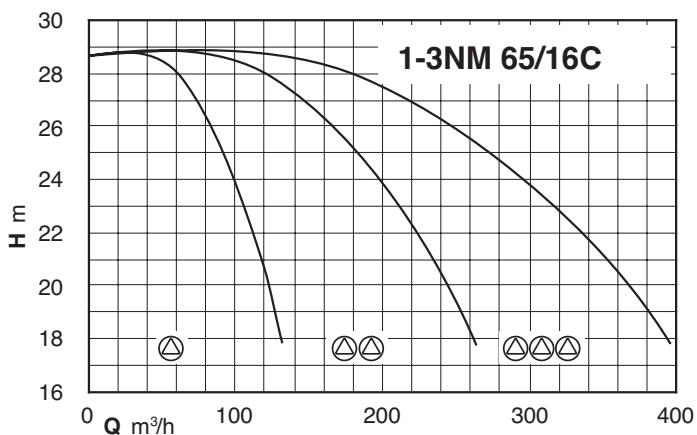
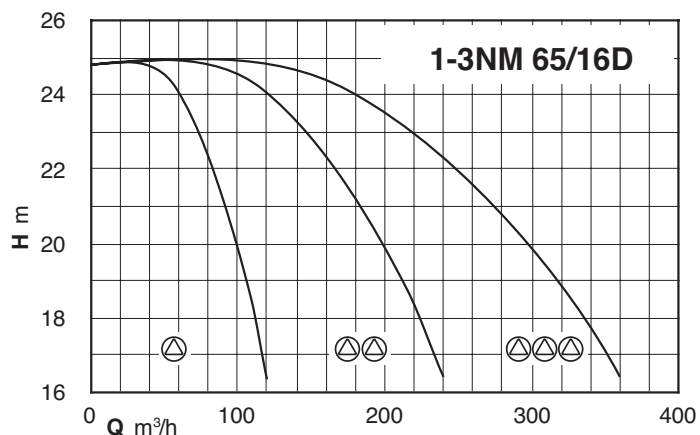
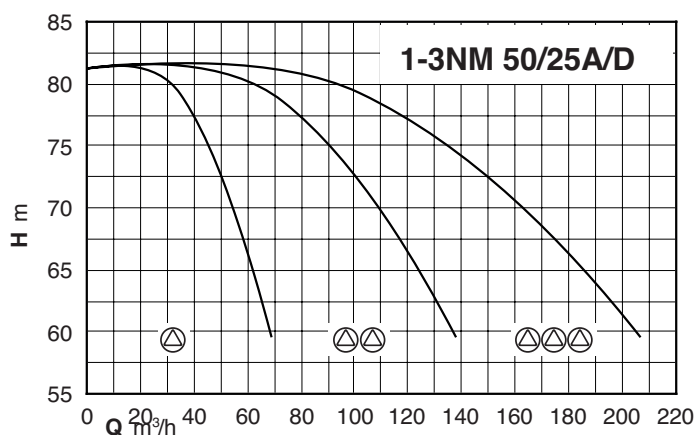
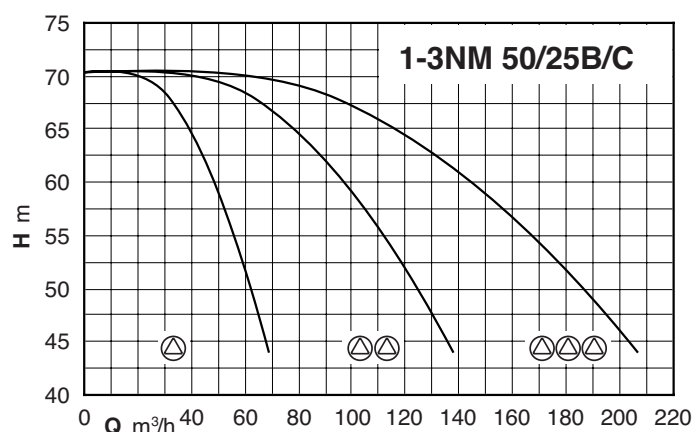
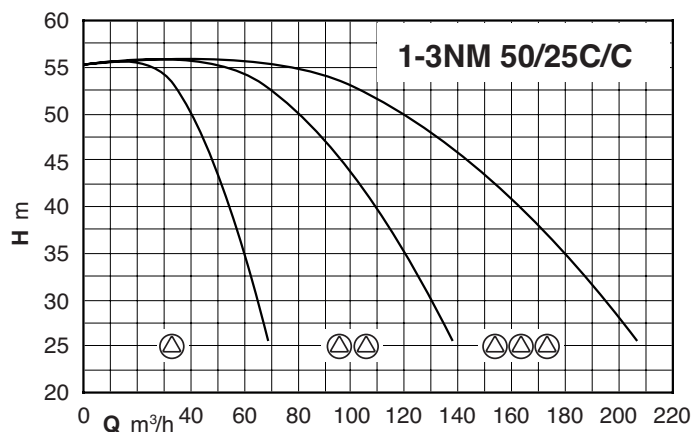

**Characteristic curves**

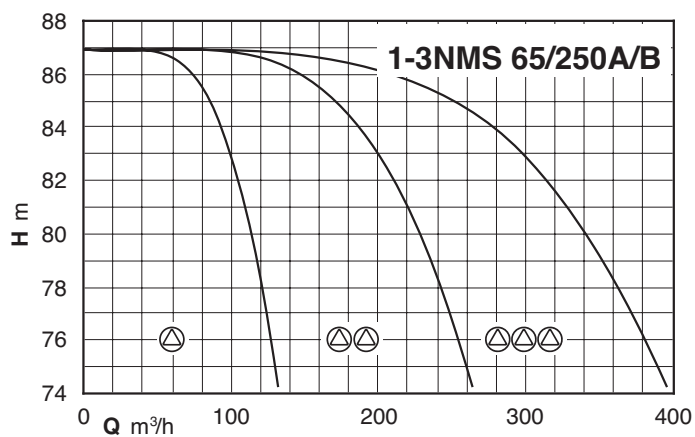
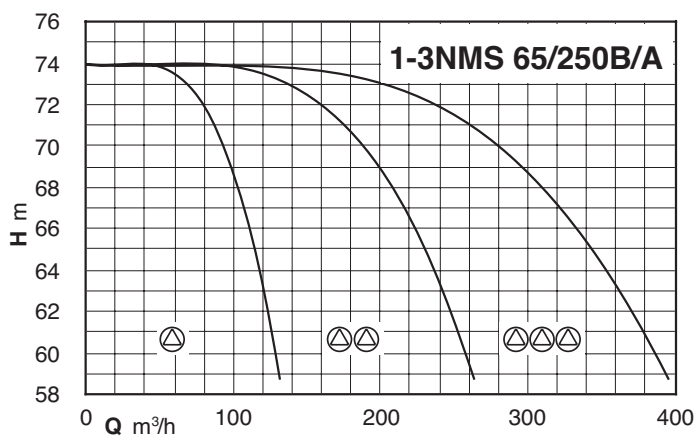
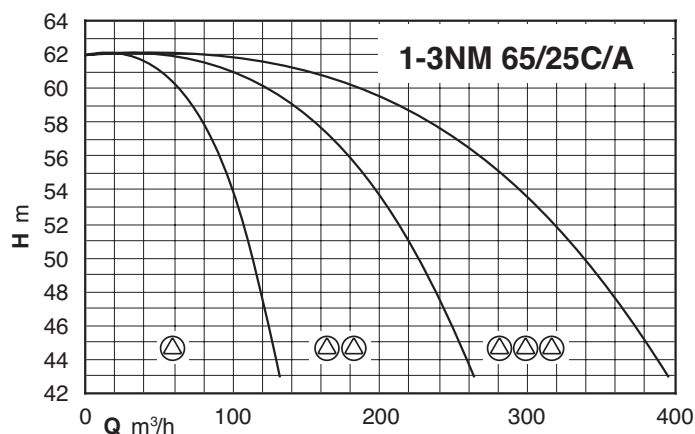
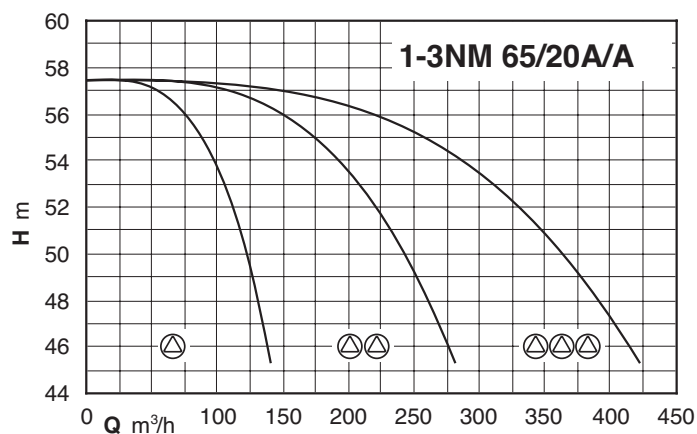
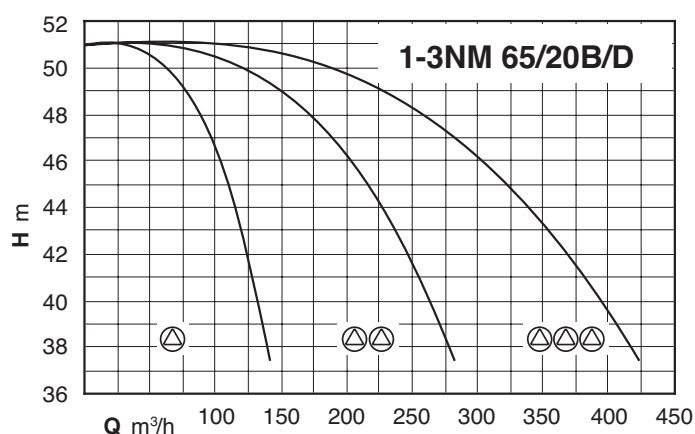
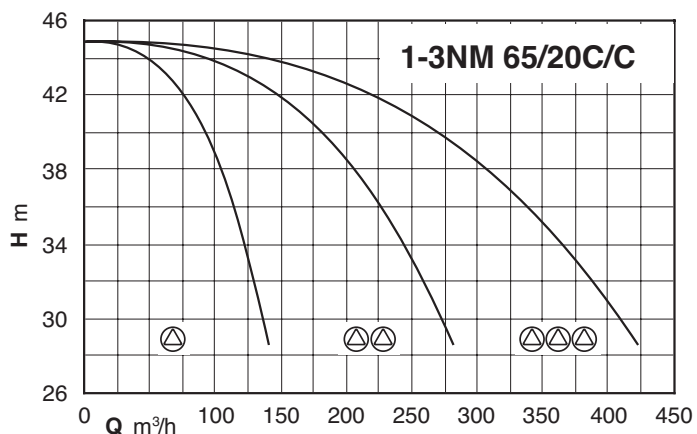

## Characteristic curves

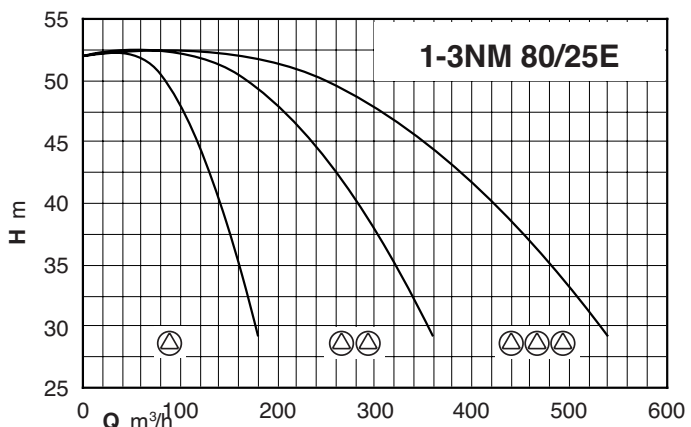
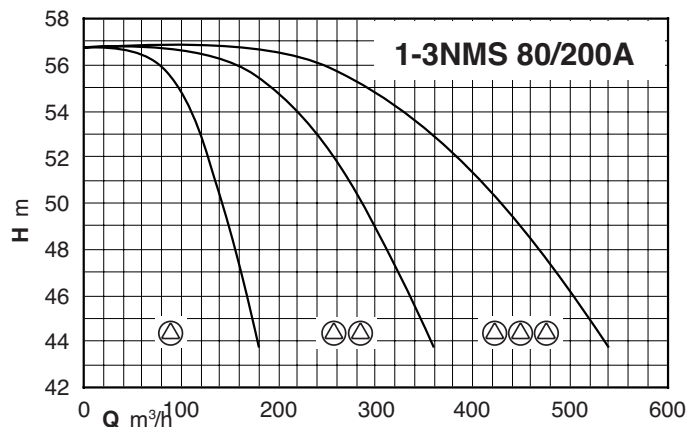
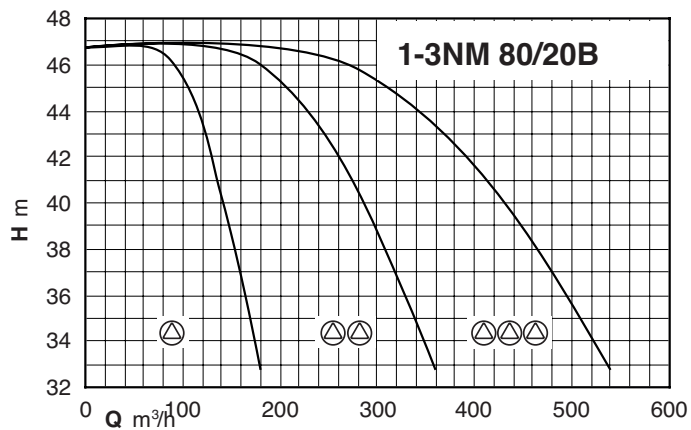
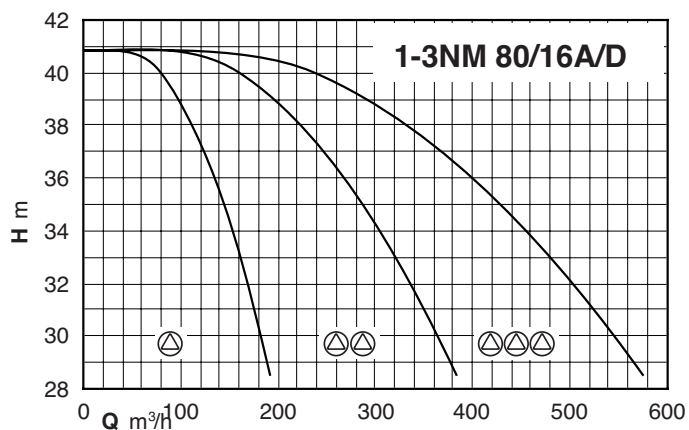
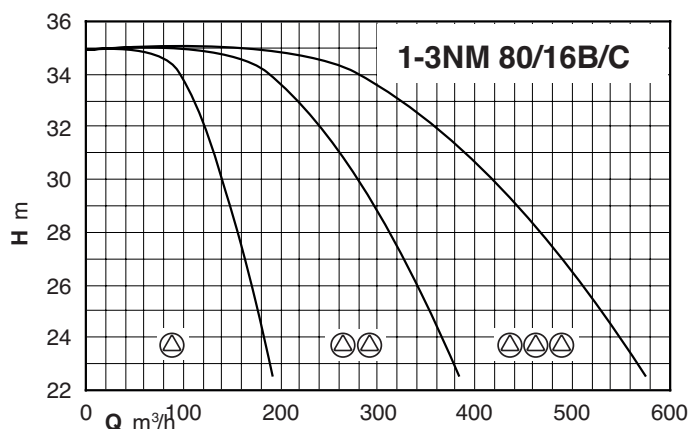
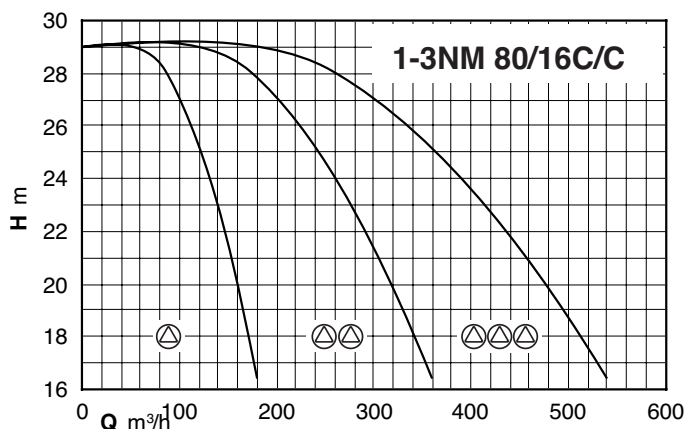
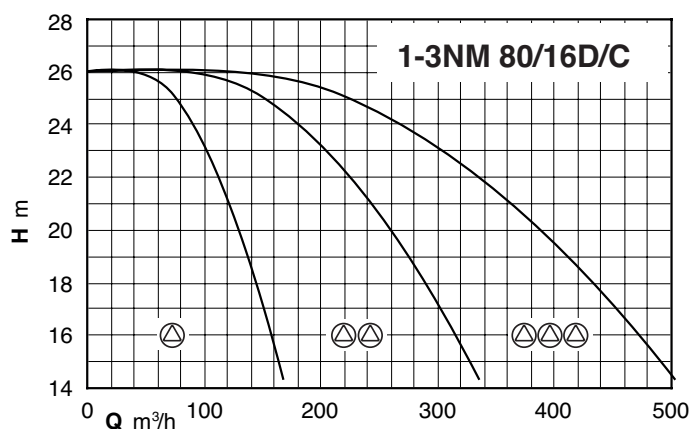
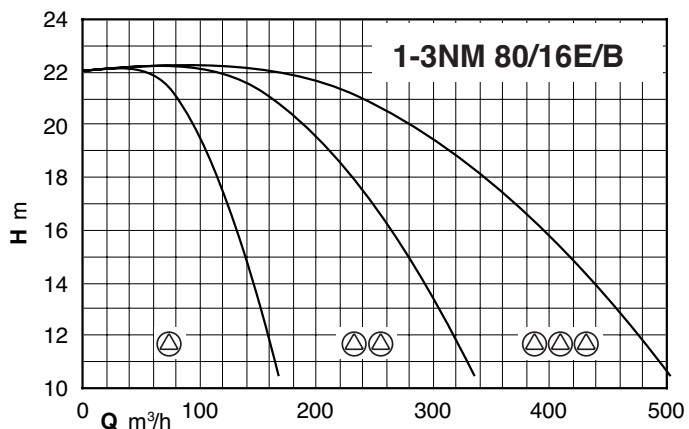

**Characteristic curves**

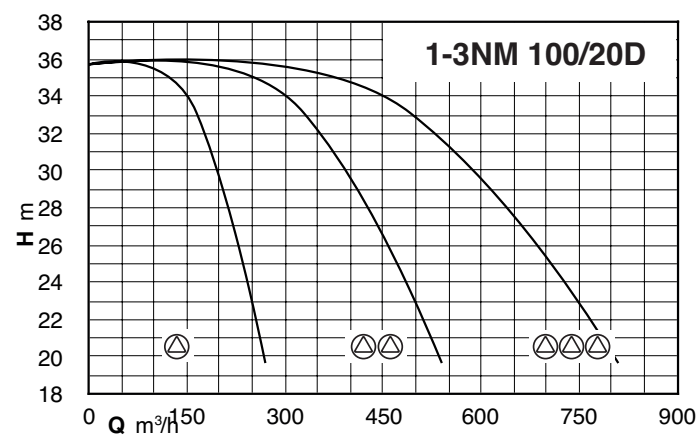
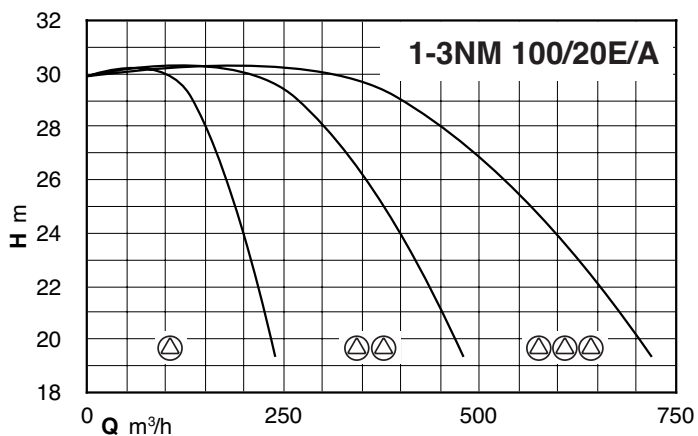
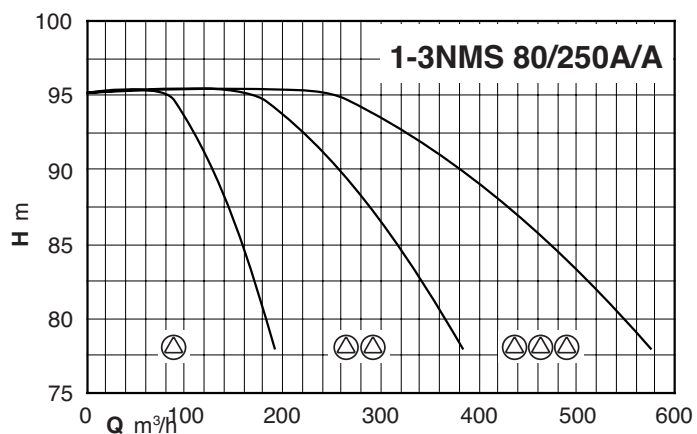
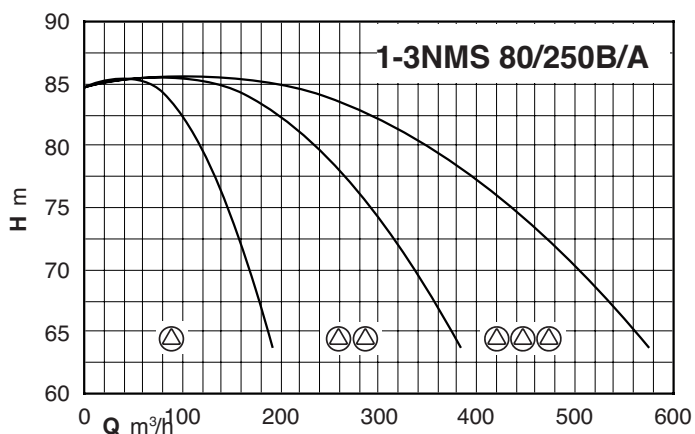
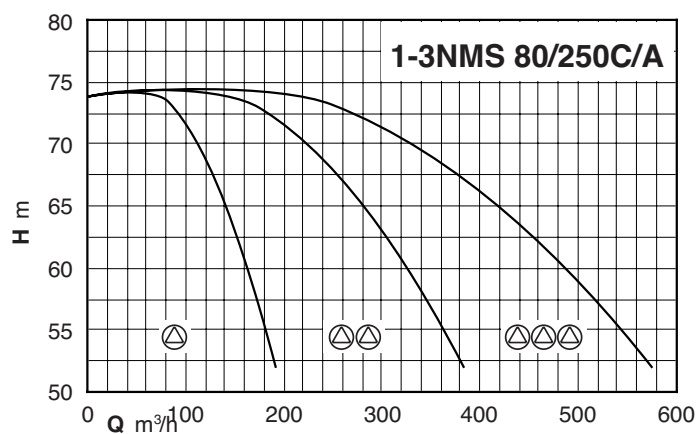
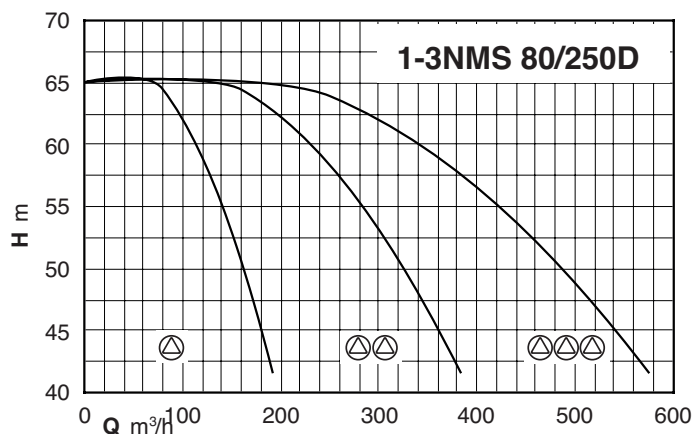

# BS, NM, NMD



## Fixed speed pump units

### BS2F

Model	P2 kW	Pressure switch		Tank	
		1	2	membrane	Vessel
		Start/Stop bar		litri	
BS2F 2 NMD 20/110B/A	0.45 X2	2.1 - 2.9	1.8 - 2.6	24X2	100
BS2F 2 NMD 20/110A/B	0.75 X2	3 - 3.9	2.7 - 3.6	100	200
BS2F 2 NMD 20/140B/A	1.1 X2	3.3 - 4.8	3 - 4.5	80	100
BS2F 2 NMD 20/140A/A	1.5 X2	4.3 - 6	4.1 - 5.7	100	200
BS2F 2 NMD 25/190C/B	2.2 X2	3.9 - 5.5	3.7 - 5.2	200	300
BS2F 2 NMD 25/190B/A	3 X2	5 - 6.8	4.8 - 6.5	300	500
BS2F 2 NMD 25/190A/B	4 X2	6.8 - 8.8	6.5 - 8.5	300	500
BS2F 2 NM 32/16B/A	1.5 X2	1.8 - 2.6	1.5 - 2.3	300	800
BS2F 2 NM 32/16A/B	2.2 X2	2.4 - 3.2	2.1 - 2.9	500	800
BS2F 2 NM 32/20C/A	3 X2	3.1 - 4	2.8 - 3.7	500	1000
BS2F 2 NM 32/20A/B	4 X2	3.6 - 5.2	3.3 - 4.9	200	300
BS2F 2 NM 32L/16B	3 X2	1.9 - 2.7	1.6 - 2.4	200	300
BS2F 2 NM 32L/16A	4 X2	2.8 - 3.6	2.5 - 3.3	200	300
BS2F 2 NM 32L/20B	5.5 X2	3.2 - 4.7	2.9 - 4.4	200	300
BS2F 2 NM 32L/20A	7.5 X2	3.7 - 5.4	3.5 - 5.1	200	300
BS2F 2 NMD 32/210D/B	4 X2	4.7 - 6.4	4.4 - 6.1	500	800
BS2F 2 NMD 32/210C/A	5.5 X2	5.7 - 7.6	5.5 - 7.3	500	1000
BS2F 2 NMD 32/210B/A	7.5 X2	7.3 - 9.4	7 - 9.1	750	1000
BS2F 2 NMD 32/210A/B	9.2 X2	8.8 - 10.3	8.5 - 10	1000	2000
BS2F 2 NMD 40/180D/B	4 X2	3.8 - 5.4	3.5 - 5.1	500	1000
BS2F 2 NMD 40/180C/A	5.5 X2	4.5 - 6.2	4.3 - 5.9	750	1500
BS2F 2 NMD 40/180B/A	7.5 X2	5.9 - 7.8	5.7 - 7.5	1000	1500
BS2F 2 NMD 40/180A/B	9.2 X2	6.5 - 8.5	6.2 - 8.2	1000	2000
BS2F 2 NM 40/16B/B	3 X2	1.8 - 2.6	1.5 - 2.3	750	2000
BS2F 2 NM 40/16A/C	4 X2	2.5 - 3.3	2.2 - 3	1500	3000
BS2F 2 NM 40/20B/A	5.5 X2	3 - 4.5	2.7 - 4.2	1000	2000
BS2F 2 NM 40/20A/A	7.5 X2	3.6 - 5.1	3.3 - 4.8	1500	3000
BS2F 2 NM 40/25B/C	11 X2	4.5 - 6.2	4.3 - 5.9	2000	3000
BS2F 2 NM 40/25A/C	15 X2	6.1 - 8.1	5.9 - 7.8	3000	4000
BS2F 2 NM 50/16B/B	5.5 X2	2 - 2.8	1.7 - 2.5	2000	4000
BS2F 2 NM 50/16A/B	7.5 X2	2.6 - 3.4	2.3 - 3.1	3000	6000
BS2F 2 NM 50/20B/C	9.2 X2	3.4 - 4.3	3.1 - 4	-	6000
BS2F 2 NM 50/20A/C	11 X2	3.3 - 4.9	3.1 - 4.6	3000	5000
BS2F 2 NM 50/25C/C	11 X2	3.4 - 4.9	3.1 - 4.6	3000	5000
BS2F 2 NM 50/25B/C	15 X2	4.5 - 6.2	4.2 - 5.9	-	6000
BS2F 2 NM 50/25A/D	18.5 X2	5.4 - 7.2	5.1 - 6.9	-	8000
BS2F 2 NM 65/16B/C	11 X2	2.1 - 2.9	1.8 - 2.6	-	10000
BS2F 2 NM 65/16AR	15 X2	2.4 - 3.2	2.1 - 2.9	-	-
BS2F 2 NM 65/16A/C	15 X2	2.8 - 3.6	2.5 - 3.3	-	-
BS2F 2 NM 65/20C/C	15 X2	3 - 3.9	2.7 - 3.6	-	-
BS2F 2 NM 65/20B/D	18.5 X2	2.9 - 4.4	2.6 - 4.1	-	-
BS2F 2 NM 65/20A/A	22 X2	3.5 - 5	3.2 - 4.7	-	-
BS2F 2 NM 65/25C/A	22 X2	4.1 - 5.7	3.8 - 5.4	-	-
BS2F 2 NMS 65/250B/A	30 X2	5.3 - 7.1	5 - 6.8	-	6000
BS2F 2 NMS 65/250A/B	37 X2	6.1 - 8.1	5.9 - 7.8	2000	3000
BS2F 2 NM 80/16B/C	15 X2	2.3 - 3.1	2 - 2.8	-	-
BS2F 2 NM 80/16A/D	18.5 X2	2.7 - 3.5	2.4 - 3.2	-	-
BS2F 2 NM 80/20B	22 X2	3.2 - 4.1	2.9 - 3.8	-	-
BS2F 2 NMS 80/200A	30 X2	3.4 - 5	3.1 - 4.7	-	-
BS2F 2 NM 80/25E	22 X2	3 - 4.5	2.7 - 4.2	-	-
BS2F 2 NMS 80/250D	30 X2	4.1 - 5.8	3.9 - 5.5	-	-
BS2F 2 NMS 80/250C/A	37 X2	4.8 - 6.6	4.5 - 6.3	-	-
BS2F 2 NMS 80/250B/A	45 X2	5.7 - 7.6	5.4 - 7.3	-	-
BS2F 2 NMS 80/250A/A	55 X2	6.6 - 8.6	6.3 - 8.3	-	-

Start and stop pressure controlled by pressure switches

### BS3F

Model	P2 kW	Transducer 1 Start/Stop bar	Tank	
			membrane	Vessel
			litri	
BS3F 3 NM 32L/16B	3 X3	1.9 - 2.7	750	2000
BS3F 3 NM 32L/16A	4 X3	2.8 - 3.6	750	2000
BS3F 3 NM 32L/20B	5.5 X3	3.2 - 4.7	750	2000
BS3F 3 NM 32L/20A	7.5 X3	3.7 - 5.4	750	2000
BS3F 3 NM 40/16B/B	3 X3	1.8 - 2.6	750	2000
BS3F 3 NM 40/16A/C	4 X3	2.5 - 3.3	1500	3000
BS3F 3 NM 40/20B/A	5.5 X3	3 - 4.5	1000	2000
BS3F 3 NM 40/20A/A	7.5 X3	3.5 - 5.1	1500	3000
BS3F 3 NM 40/25B/C	11 X3	4.5 - 6.2	2000	3000
BS3F 3 NM 40/25A/C	15 X3	6.1 - 8.1	3000	4000
BS3F 3 NM 50/16B/B	5.5 X3	2 - 2.8	2000	4000
BS3F 3 NM 50/16A/B	7.5 X3	2.6 - 3.4	3000	6000
BS3F 3 NM 50/20B/C	9.2 X3	3.4 - 4.3	-	6000
BS3F 3 NM 50/20A/C	11 X3	3.4 - 4.9	3000	5000
BS3F 3 NM 50/25C/C	11 X3	3.4 - 4.9	3000	5000
BS3F 3 NM 50/25B/C	15 X3	4.5 - 6.2	-	6000
BS3F 3 NM 50/25A/D	18.5 X3	5.4 - 7.2	-	8000
BS3F 3 NM 65/16B/C	11 X3	2.1 - 2.9	-	10000
BS3F 3 NM 65/16AR	15 X3	2.4 - 3.2	-	-
BS3F 3 NM 65/16A/C	15 X3	2.8 - 3.6	-	-
BS3F 3 NM 65/20C/C	15 X3	3 - 3.9	-	-
BS3F 3 NM 65/20B/D	18.5 X3	2.9 - 4.4	-	-
BS3F 3 NM 65/20A/A	22 X3	3.5 - 5	-	-
BS3F 3 NM 65/25C/A	22 X3	4 - 5.7	-	-
BS3F 3 NMS 65/250B/A	30 X3	5.3 - 7.1	-	-
BS3F 3 NMS 65/250A/B	37 X3	6.1 - 8.1	-	-
BS3F 3 NM 80/16B/C	15 X3	2.3 - 3.1	-	-
BS3F 3 NM 80/16A/D	18.5 X3	2.7 - 3.5	-	-
BS3F 3 NM 80/20B	22 X3	3.2 - 4.1	-	-
BS3F 3 NMS 80/200A	30 X3	3.4 - 4.9	-	-
BS3F 3 NM 80/25E	22 X3	3 - 4.5	-	-
BS3F 3 NMS 80/250D	30 X3	4.1 - 5.8	-	-
BS3F 3 NMS 80/250C/A	37 X3	4.8 - 6.6	-	-
BS3F 3 NMS 80/250B/A	45 X3	5.7 - 7.6	-	-
BS3F 3 NMS 80/250A/A	55 X3	6.6 - 8.6	-	-

Start and stop pressure controlled by a pressure transducer



# BS, NM, NMD



## Variable speed pump units with frequency converter

### BS2V ..ITT

Model	P2
	kW
BS2V 2 NM 32/16B/A-ITT	1.5 X2
BS2V 2 NM 32/16A/B-ITT	2.2 X2
BS2V 2 NM 32/20D/B-ITT	2.2 X2
BS2V 2 NM 32/20C/A-ITT	3 X2
BS2V 2 NM 32/20A/B-ITT	4 X2
BS2V 2 NM 32L/16B-ITT	3 X2
BS2V 2 NM 32L/16A-ITT	4 X2
BS2V 2 NM 32L/20B-ITT	5.5 X2
BS2V 2 NM 32L/20A-ITT	7.5 X2
BS2V 2 NM 40/16C/C-ITT	2.2 X2
BS2V 2 NM 40/16B/B-ITT	3 X2
BS2V 2 NM 40/16A/C-ITT	4 X2
BS2V 2 NM 40/20D/B-ITT	4 X2
BS2V 2 NM 40/20C/B-ITT	4 X2
BS2V 2 NM 40/20B/A-ITT	5.5 X2
BS2V 2 NM 40/20AR/A-ITT	5.5 X2
BS2V 2 NM 40/20A/A-ITT	7.5 X2
BS2V 2 NM 40/25C/C-ITT	9.2 X2
BS2V 2 NM 40/25B/C-ITT	11 X2
BS2V 2 NM 40/25A/C-ITT	15 X2
BS2V 2 NM 50/16B/B-ITT	5.5 X2
BS2V 2 NM 50/16A/B-ITT	7.5 X2
BS2V 2 NM 50/20B/C-ITT	9.2 X2
BS2V 2 NM 50/20A/C-ITT	11 X2
BS2V 2 NM 50/20S/C-ITT	15 X2
BS2V 2 NM 50/25C/C-ITT	11 X2
BS2V 2 NM 50/25B/C-ITT	15 X2
BS2V 2 NM 50/25A/D-ITT	18.5 X2
BS2V 2 NM 65/16D/B-ITT	7.5 X2
BS2V 2 NM 65/16C/C-ITT	9.2 X2
BS2V 2 NM 65/16B/C-ITT	11 X2
BS2V 2 NM 65/16AR-ITT	15 X2
BS2V 2 NM 65/16A/C-ITT	15 X2
BS2V 2 NM 65/20C/C-ITT	15 X2
BS2V 2 NM 65/20B/D-ITT	18.5 X2
BS2V 2 NM 65/20A/A-ITT	22 X2
BS2V 2 NM 65/25C/A-ITT	22 X2
BS2V 2 NM 80/16E/B-ITT	7.5 X2
BS2V 2 NM 80/16D/C-ITT	9.2 X2
BS2V 2 NM 80/16C/C-ITT	11 X2
BS2V 2 NM 80/16B/C-ITT	15 X2
BS2V 2 NM 80/16A/D-ITT	18.5 X2
BS2V 2 NM 80/20B-ITT	22 X2
BS2V 2 NM 80/25E-ITT	22 X2
BS2V 2 NM 100/20E/A-ITT	18.5 X2
BS2V 2 NM 100/20D-ITT	22 X2

### BS3V ..ITT

Model	P2
	kW
BS3V 3 NM 32/16B/A-ITT	1.5 X3
BS3V 3 NM 32/16A/B-ITT	2.2 X3
BS3V 3 NM 32/20D/B-ITT	2.2 X3
BS3V 3 NM 32/20C/A-ITT	3 X3
BS3V 3 NM 32/20A/B-ITT	4 X3
BS3V 3 NM 32L/16B-ITT	3 X3
BS3V 3 NM 32L/16A-ITT	4 X3
BS3V 3 NM 32L/20B-ITT	5.5 X3
BS3V 3 NM 32L/20A-ITT	7.5 X3
BS3V 3 NM 40/16C/C-ITT	2.2 X3
BS3V 3 NM 40/16B/B-ITT	3 X3
BS3V 3 NM 40/16A/C-ITT	4 X3
BS3V 3 NM 40/20D/B-ITT	4 X3
BS3V 3 NM 40/20C/B-ITT	4 X3
BS3V 3 NM 40/20B/A-ITT	5.5 X3
BS3V 3 NM 40/20AR/A-ITT	5.5 X3
BS3V 3 NM 40/20A/A-ITT	7.5 X3
BS3V 3 NM 40/25C/C-ITT	9.2 X3
BS3V 3 NM 40/25B/C-ITT	11 X3
BS3V 3 NM 40/25A/C-ITT	15 X3
BS3V 3 NM 50/16B/B-ITT	5.5 X3
BS3V 3 NM 50/16A/B-ITT	7.5 X3
BS3V 3 NM 50/20B/C-ITT	9.2 X3
BS3V 3 NM 50/20A/C-ITT	11 X3
BS3V 3 NM 50/20S/C-ITT	15 X3
BS3V 3 NM 50/25C/C-ITT	11 X3
BS3V 3 NM 50/25B/C-ITT	15 X3
BS3V 3 NM 50/25A/D-ITT	18.5 X3
BS3V 3 NM 65/16D/B-ITT	7.5 X3
BS3V 3 NM 65/16C/C-ITT	9.2 X3
BS3V 3 NM 65/16B/C-ITT	11 X3
BS3V 3 NM 65/16AR-ITT	15 X3
BS3V 3 NM 65/16A/C-ITT	15 X3
BS3V 3 NM 65/20C/C-ITT	15 X3
BS3V 3 NM 65/20B/D-ITT	18.5 X3
BS3V 3 NM 65/20A/A-ITT	22 X3
BS3V 3 NM 65/25C/A-ITT	22 X3
BS3V 3 NM 80/16E/B-ITT	7.5 X3
BS3V 3 NM 80/16D/C-ITT	9.2 X3
BS3V 3 NM 80/16C/C-ITT	11 X3
BS3V 3 NM 80/16B/C-ITT	15 X3
BS3V 3 NM 80/16A/D-ITT	18.5 X3
BS3V 3 NM 80/20B-ITT	22 X3
BS3V 3 NM 80/25E-ITT	22 X3
BS3V 3 NM 100/20E/A-ITT	18.5 X3
BS3V 3 NM 100/20D-ITT	22 X3

# BS, NM, NMD



## Dimensions and weights

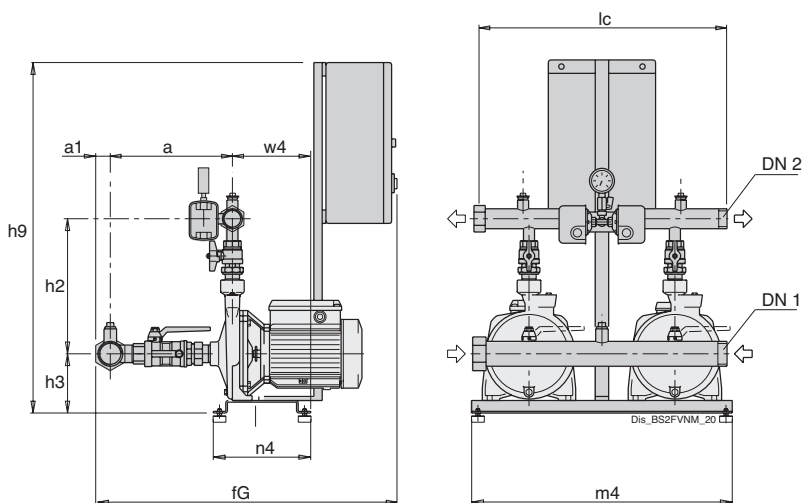

TYPE	Manifolds		mm										Kg Weight
	DN1	DN2	a	a1	fG	h2	h3	h9	lc	m4	n4	w4	
BS2F 2 NMD 20/110B/A	G 2	G 1 1/2	315	32	670	277	129	840	600	625	365	280	45.8
BS2F 2 NMD 20/110A/B	G 2	G 1 1/2	315	32	670	277	129	840	600	625	365	280	52.6
BS2F 2 NMD 20/140B/A	G 2	G 1 1/2	320	32	670	295	146	840	600	625	365	280	70
BS2F 2 NMD 20/140A/A	G 2	G 1 1/2	320	32	670	295	146	840	600	625	365	280	74.6
BS2F 2 NMD 25/190C/B	G 2 1/2	G 2	407	40	760	330	175	840	600	625	365	280	109
BS2F 2 NMD 25/190B/A	G 2 1/2	G 2	407	40	760	330	175	840	600	625	365	280	120.8
BS2F 2 NMD 25/190A/B	G 2 1/2	G 2	407	40	760	330	175	840	600	625	365	280	127
BS2F 2 NMD 32/210D/B	G 3	G 2 1/2	389	48	460	380	245	890	700	800	550	493	180.5
BS2F 2 NMD 32/210C/A	G 3	G 2 1/2	389	48	460	380	272	890	700	800	550	493	181
BS2F 2 NMD 32/210B/A	G 3	G 2 1/2	389	48	460	380	272	1370	700	800	550	493	-
BS2F 2 NMD 32/210A/B	G 3	G 2 1/2	389	48	460	380	307	1370	700	800	550	493	267
BS2F 2 NMD 40/180D/B	G 3	G 2 1/2	477	48	475	460	245	890	700	800	550	519	185.3
BS2F 2 NMD 40/180C/A	G 3	G 2 1/2	477	48	475	460	272	890	700	800	550	519	182
BS2F 2 NMD 40/180B/A	G 3	G 2 1/2	477	48	475	460	272	1370	700	800	550	519	243
BS2F 2 NMD 40/180A/B	G 3	G 2 1/2	477	48	475	460	307	1370	700	800	550	519	266

Non-binding dimensions to be checked when ordering

Anti-vibration kit supplied disassembled as standard

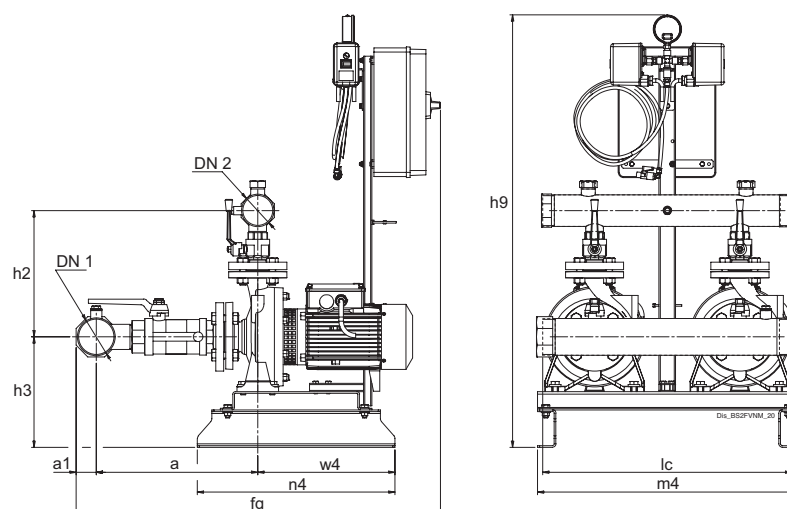

TYPE	Manifolds		mm										Kg Weight
	DN1	DN2	a	a1	fG	h1	h3	h9	lc	m4	n4	w4	
BS2F 2 NM 32/16B/A	G 3	G 2 1/2	304	48	878	266	345	830	600	625	476	389	114.6
BS2F 2 NM 32/16A/B	G 3	G 2 1/2	304	48	878	266	345	830	600	625	476	389	117
BS2F 2 NM 32/20C/A	G 3	G 2 1/2	324	48	878	294	365	830	600	625	476	389	143
BS2F 2 NM 32/20A/B	G 3	G 2 1/2	324	48	878	294	365	830	600	625	476	389	144.1

Non-binding dimensions to be checked when ordering

# BS, NM, NMD



## Dimensions and weights

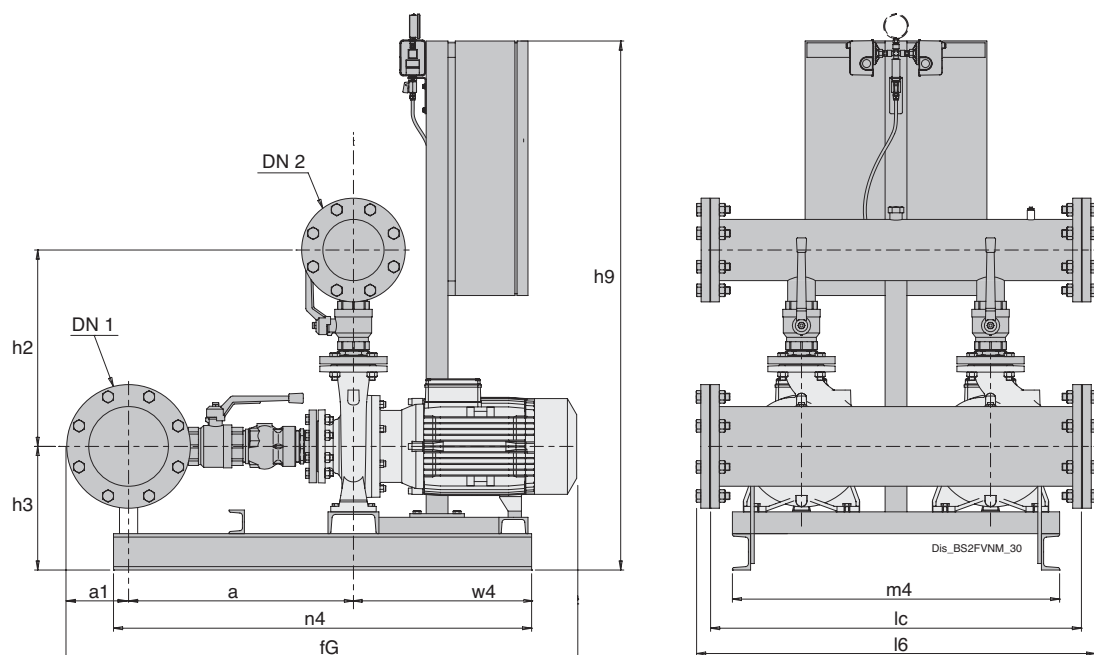

TYPE	Manifolds		mm										Kg Weight	
	DN1	DN2	a	a1	fG	h2	h3	h9	l6	lc	m4	n4		w4
BS2F 2 NM 32L/16B	100	80	487	110	1008	383	281	830	886	820	800	476	352	144.1
BS2F 2 NM 32L/16A	100	80	487	110	1008	383	281	830	886	820	800	476	352	144.1
BS2F 2 NM 32L/20B	100	80	507	110	1008	383	281	830	886	820	900	1040	325	-
BS2F 2 NM 32L/20A	100	80	207	110	1008	383	281	1310	886	820	900	1040	352	144.1
BS2F 2 NM 40/16B/B	100	80	487	110	1008	383	281	830	886	820	800	476	325	190
BS2F 2 NM 40/16A/C	100	80	487	110	1008	383	281	830	886	820	800	476	325	195
BS2F 2 NM 40/20B/A	100	80	507	110	1245	403	320	830	886	820	900	1040	627.5	271.5
BS2F 2 NM 40/20A/A	100	80	507	110	1245	403	320	1310	886	820	900	1040	627.5	311
BS2F 2 NM 40/25B/C	100	80	507	110	1245	448	340	1455	886	820	900	1040	627.5	428
BS2F 2 NM 40/25A/C	100	80	507	110	1245	448	340	1455	886	820	900	1040	627.5	-
BS2F 2 NM 50/16B/B	125	100	515	125	1568	517	320	975	988	920	900	1500	628	391.6
BS2F 2 NM 50/16A/B	125	100	515	125	1568	517	320	1455	988	920	900	1500	628	439
BS2F 2 NM 50/20B/C	125	100	515	125	1568	537	320	1455	988	920	900	1500	628	491
BS2F 2 NM 50/20A/C	125	100	515	125	1568	537	320	1455	988	920	900	1500	628	532
BS2F 2 NM 50/25C/C	125	100	515	125	1754	562	340	1455	988	920	900	1500	628	-
BS2F 2 NM 50/25B/C	125	100	515	125	1754	562	340	1455	988	920	900	1500	628	581.5
BS2F 2 NM 50/25A/D	125	100	515	125	1754	562	340	1455	988	920	900	1500	628	-
BS2F 2 NM 65/16B/C	200	150	625	170	1800	571	320	1455	1100	1020	900	1500	628	-
BS2F 2 NM 65/16A/R	200	150	625	170	1800	571	320	1455	1100	1020	900	1500	628	107.5
BS2F 2 NM 65/16A/C	200	150	625	170	1800	571	320	1455	1100	1020	900	1500	628	-
BS2F 2 NM 65/20C/C	200	150	625	170	1800	596	340	1455	1277	1200	1080	1500	628	-
BS2F 2 NM 65/20B/D	200	150	625	170	1800	596	340	1455	1277	1200	1080	1500	628	-
BS2F 2 NM 65/20A/A	200	150	625	170	1800	596	340	1455	1277	1200	1080	1500	628	765
BS2F 2 NM 65/25C/A	200	150	625	170	1800	596	340	1455	1277	1200	1080	1500	628	107.5
BS2F 2 NMS 65/250B/A	200	150	625	170	1882	621	430	1655	1277	1200	1200	1750	845	-
BS2F 2 NMS 65/250A/B	200	150	625	170	1882	621	430	1855	1277	1200	1200	1750	845	107.5
BS2F 2 NM 80/16B/C	250	200	730	202.5	1852	653	340	1455	1283	1200	1080	1650	628	-
BS2F 2 NM 80/16A/D	250	200	730	202.5	1852	653	340	1455	1283	1200	1080	1650	628	-
BS2F 2 NM 80/20B	250	200	730	202.5	1852	653	340	1455	1283	1200	1080	1650	628	107.5
BS2F 2 NMS 80/200A	250	200	730	202.5	-	-	-	1655	-	1200	-	-	-	107.5
BS2F 2 NM 80/25E	250	200	730	202.5	-	-	-	1655	-	1200	-	-	-	107.5
BS2F 2 NMS 80/250D	250	200	730	202.5	-	-	-	1655	-	1200	-	-	-	-
BS2F 2 NMS 80/250C/A	250	200	730	202.5	-	-	-	1855	-	1200	-	-	-	-
BS2F 2 NMS 80/250B/A	250	200	730	202.5	-	708	480	1400	1283	1200	1200	2050	943	107.5
BS2F 2 NMS 80/250A/A	250	200	730	202.5	-	-	-	1400	-	1200	-	-	-	107.5

Non-binding dimensions to be checked when ordering  
Missing dimensions on request

# BS, NM, NMD



## Dimensions and weights

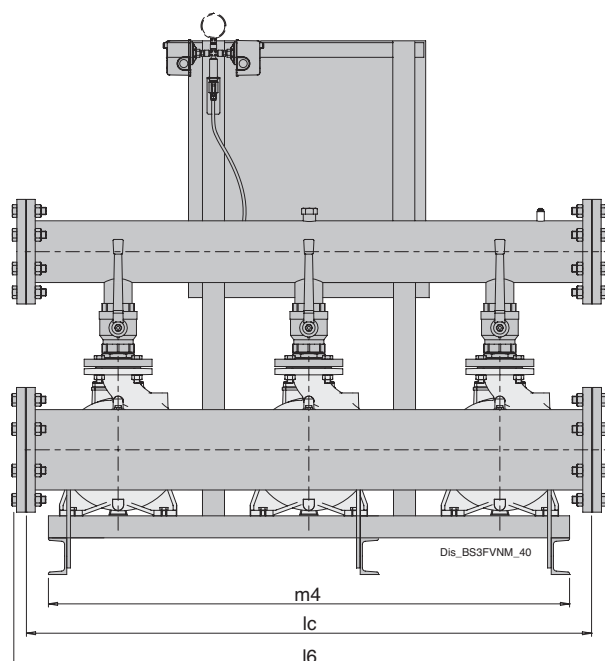
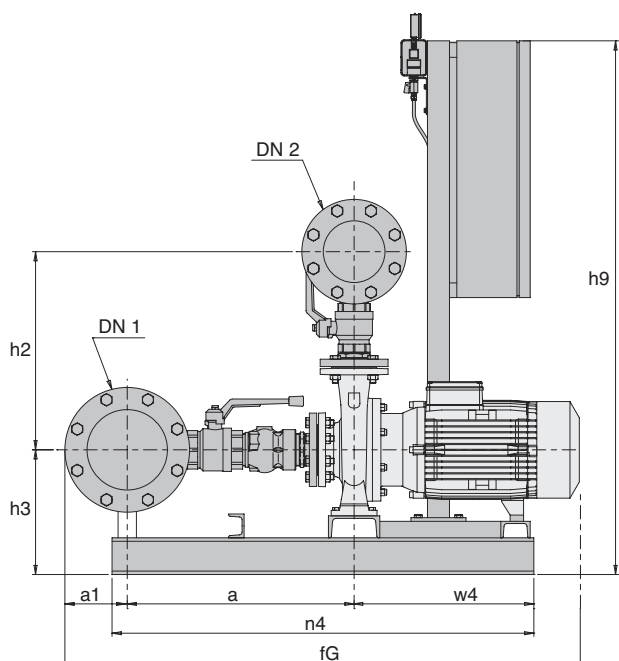

TYPE	Manifolds		mm											Kg Weight
	DN1	DN2	a	a1	fg	h2	h3	h9	l6	lc	m4	n4	w4	
BS3F 3 NM 40/16B/B	125	100	500	125	1300	400	292	1165	1408	1340	1400	1030	558	358
BS3F 3 NM 40/16A/C	125	100	500	125	1300	400	292	1165	1408	1340	1400	1030	558	-
BS3F 3 NM 40/20B/A	125	100	520	125	1300	420	320	1165	1408	1340	1400	1030	558	-
BS3F 3 NM 40/20A/A	125	100	520	125	1300	420	320	1410	1408	1340	1400	1030	558	447
BS3F 3 NM 40/25B/C	125	100	520	125	1357	465	340	1555	1408	1340	1400	1030	558	-
BS3F 3 NM 40/25A/C	125	100	520	125	1357	465	340	1555	1408	1340	1400	1030	558	-
BS3F 3 NM 50/16B/B	150	125	525	142.5	1690	575	315	975	1515	1340	1400	1430	563	-
BS3F 3 NM 50/16A/B	150	125	525	142.5	1690	575	315	1555	1515	1340	1400	1430	563	631
BS3F 3 NM 50/20B/C	150	125	525	142.5	1690	575	315	1555	1515	1340	1400	1430	563	-
BS3F 3 NM 50/20A/C	150	125	525	142.5	1690	575	315	1555	1515	1340	1400	1430	563	-
BS3F 3 NM 50/25C/C	150	125	525	142.5	1690	575	340	1555	1515	1440	1400	1430	563	-
BS3F 3 NM 50/25B/C	150	125	525	142.5	1690	575	340	1555	1515	1440	1400	1430	563	858
BS3F 3 NM 50/25A/D	150	125	525	142.5	1690	575	340	1555	1515	1440	1400	1430	563	-
BS3F 3 NM 65/16B/C	250	200	650	202.5	1690	555	320	1555	1623	1540	1400	1430	563	706
BS3F 3 NM 65/16A/R	250	200	650	202.5	1690	555	320	1555	1623	1540	1400	1430	563	-
BS3F 3 NM 65/16A/C	250	200	650	202.5	1690	555	320	1555	1623	1540	1400	1430	563	800
BS3F 3 NM 65/20C/C	250	200	650	202.5	1794	620	340	1555	1623	1540	1400	1430	563	-
BS3F 3 NM 65/20B/D	250	200	650	202.5	1741	620	340	1755	1623	1900	1780	1550	628	-
BS3F 3 NM 65/20A/A	250	200	650	202.5	1741	620	340	1755	1623	1900	1780	1550	628	-
BS3F 3 NM 65/25C/A	250	200	650	202.5	1741	620	340	1755	1623	1900	1780	1550	628	-
BS3F 3 NMS 65/250B/A	250	200	650	202.5	-	605	260	1855	-	1900	-	-	-	-
BS3F 3 NMS 65/250A/B	250	200	650	202.5	-	605	310	1545	-	1900	-	-	-	-
BS3F 3 NM 80/16B/C	300	250	755	222.5	-	645	340	1555	-	1900	-	-	-	-
BS3F 3 NM 80/16A/D	300	250	755	222.5	-	645	240	1755	-	1900	-	-	-	-
BS3F 3 NM 80/20B	300	250	755	222.5	-	670	360	1855	-	1900	-	-	-	-
BS3F 3 NMS 80/200A	300	250	755	222.5	-	670	260	1855	-	1900	-	-	-	-
BS3F 3 NM 80/25E	300	250	755	222.5	-	700	360	1855	-	1900	-	-	-	-
BS3F 3 NMS 80/250D	300	250	755	222.5	-	700	260	1855	-	1900	-	-	-	-
BS3F 3 NMS 80/250C/A	300	250	755	222.5	-	700	310	1400	-	1900	-	-	-	-
BS3F 3 NMS 80/250B/A	300	250	755	222.5	-	700	310	1400	-	1900	-	-	-	-
BS3F 3 NMS 80/250A/A	300	250	755	222.5	-	700	310	1400	-	1900	-	-	-	-

Non-binding dimensions to be checked when ordering  
Missing dimensions on request

# BS, NM, NMD



## Dimensions and weights

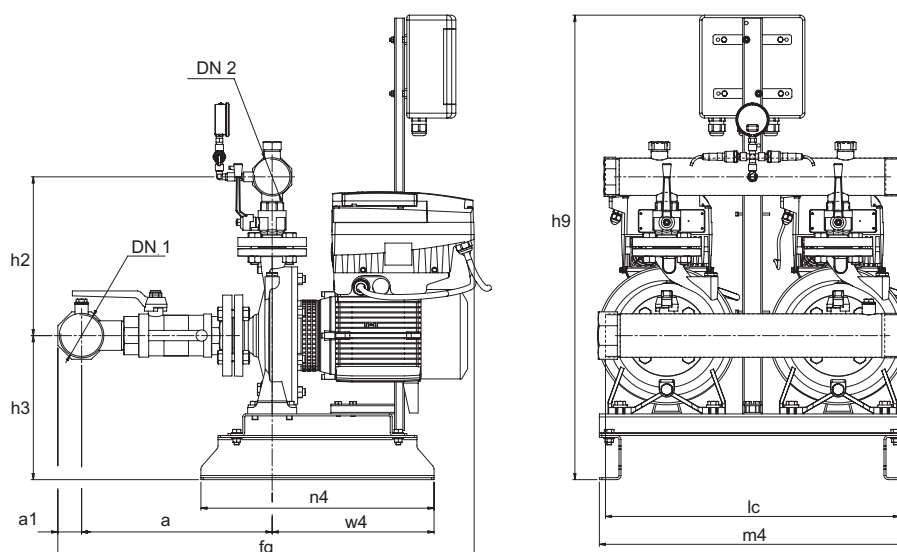

TYPE	Manifolds		mm										Kg Weight
	DN1	DN2	a	a1	fG	h1	h3	h9	lc	m4	n4	w4	
BS2V 2 NM 32/16B/A-ITT	G 3	G 2 1/2	389	48	813	266	304	948	600	625	476	330	-
BS2V 2 NM 32/16A/B-ITT	G 3	G 2 1/2	389	48	813	266	304	948	600	625	476	370	135
BS2V 2 NM 32/20D/B-ITT	G 3	G 2 1/2	389	48	850	266	304	948	600	625	476	370	-
BS2V 2 NM 32/20C/A-ITT	G 3	G 2 1/2	389	48	850	294	324	948	600	625	476	395	156.5
BS2V 2 NM 32/20A/B-ITT	G 3	G 2 1/2	389	48	850	294	324	948	600	625	476	395	164.5

Non-binding dimensions to be checked when ordering  
 Missing dimensions on request

## Dimensions and weights

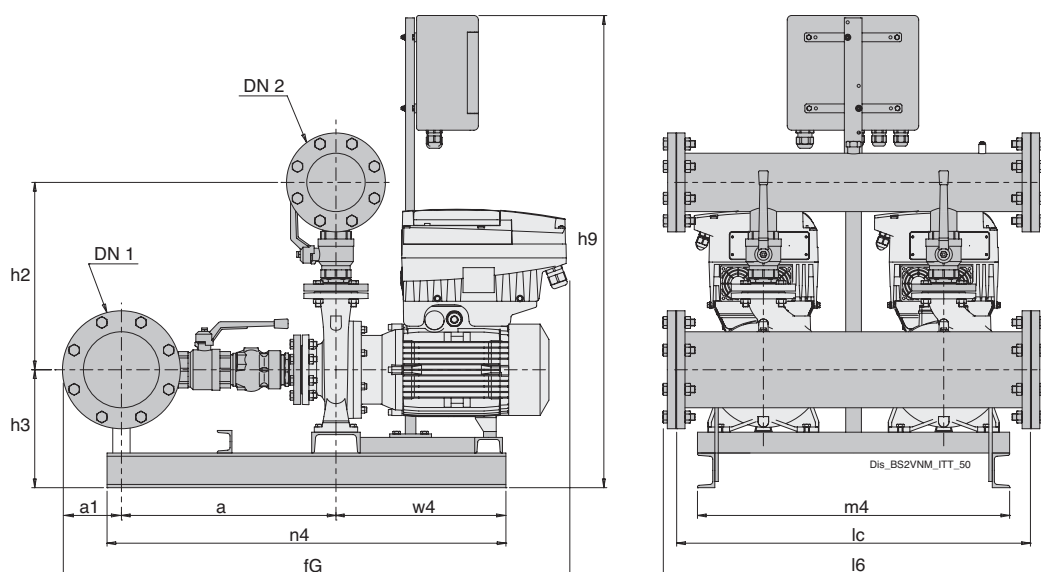

TYPE	Manifolds		mm											Kg Weight
	DN1	DN2	a	a1	fG	h2	h3	h9	l6	lc	m4	n4	w4	
BS2V 2 NM 32L/16B-ITT	100	80	487	110	1008	387	280	989	886	820	800	476	325	164.5
BS2V 2 NM 32L/16A-ITT	100	80	487	110	1008	387	280	989	886	820	800	476	325	164.5
BS2V 2 NM 32L/20B-ITT	100	80	507	110	1025	407	320	897	886	820	900	1040	325	280.4
BS2V 2 NM 32L/20A-ITT	100	80	507	110	1025	407	320	897	886	820	900	1040	325	164.5
BS2V 2 NM 40/16C/C-ITT	100	80	487	110	990	387	280	897	886	820	800	476	325	-
BS2V 2 NM 40/16B/B-ITT	100	80	487	110	1006	387	280	897	886	820	800	476	325	-
BS2V 2 NM 40/16A/C-ITT	100	80	487	110	1006	387	280	897	886	820	800	476	325	210
BS2V 2 NM 40/20D/B-ITT	100	80	507	110	1245	407	309	985	886	820	800	476	628	-
BS2V 2 NM 40/20C/B-ITT	100	80	507	110	1245	407	309	985	886	820	800	476	628	-
BS2V 2 NM 40/20B/A-ITT	100	80	507	110	1245	407	320	985	886	820	900	1040	628	286
BS2V 2 NM 40/20AR/A-ITT	100	80	507	110	1245	407	320	897	886	820	900	1040	628	284.5
BS2V 2 NM 40/20A/A-ITT	100	80	507	110	1245	407	320	897	886	820	900	1040	628	312
BS2V 2 NM 40/25C/C-ITT	100	80	507	110	1245	452	340	977	886	820	900	1040	628	-
BS2V 2 NM 40/25B/C-ITT	100	80	507	110	1245	452	340	977	886	820	900	1040	628	405
BS2V 2 NM 40/25A/C-ITT	100	80	507	110	1245	452	340	977	886	820	900	1040	628	-
BS2V 2 NM 50/16B/B-ITT	125	100	515	125	1568	435	315	1185	988	920	900	1500	628	-
BS2V 2 NM 50/16A/B-ITT	125	100	515	125	1568	435	315	1185	988	920	900	1500	628	-
BS2V 2 NM 50/20B/C-ITT	125	100	515	125	1568	455	315	1185	988	920	900	1500	628	494
BS2V 2 NM 50/20A/C-ITT	125	100	515	125	1568	455	315	1185	988	920	900	1500	628	532
BS2V 2 NM 50/20S/C-ITT	125	100	515	125	1568	455	315	1350	988	920	900	1500	628	-
BS2V 2 NM 50/25C/C-ITT	125	100	515	125	1568	480	340	1185	988	920	900	1500	628	530
BS2V 2 NM 50/25B/C-ITT	125	100	515	125	1568	480	340	1350	988	920	900	1500	628	630
BS2V 2 NM 50/25A/D-ITT	125	100	515	125	1568	480	340	1350	988	920	900	1500	628	639
BS2V 2 NM 65/16D/B-ITT	200	150	625	170	-	525	320	-	-	1020	-	-	628	-
BS2V 2 NM 65/16C/C-ITT	200	150	625	170	-	525	320	-	-	1020	-	-	628	-
BS2V 2 NM 65/16B/C-ITT	200	150	625	170	-	525	320	-	-	1020	-	-	628	-
BS2V 2 NM 65/16AR-ITT	200	150	625	170	-	525	320	-	-	1020	-	-	628	-
BS2V 2 NM 65/16A/C-ITT	200	150	625	170	-	525	320	-	-	1020	-	-	628	-
BS2V 2 NM 65/20C/C-ITT	200	150	-	170	-	550	340	-	-	1020	-	-	628	-
BS2V 2 NM 65/20B/D-ITT	200	150	852	170	1817	596	340	1200	1277	1200	900	1500	628	-
BS2V 2 NM 65/20A/A-ITT	200	150	-	170	-	550	360	-	-	1200	-	-	-	-
BS2V 2 NM 65/25C/A-ITT	200	150	852	170	1750	575	360	1490	1277	1200	1200	1560	665	862
BS2V 2 NM 80/16E/B-ITT	250	200	-	202.5	-	615	-	-	-	1050	-	-	-	-
BS2V 2 NM 80/16D/C-ITT	250	200	-	202.5	-	615	-	-	-	1050	-	-	-	-
BS2V 2 NM 80/16C/C-ITT	250	200	-	202.5	-	615	-	-	-	1050	-	-	-	-
BS2V 2 NM 80/16B/C-ITT	250	200	-	202.5	-	615	340	-	-	1050	-	-	-	-
BS2V 2 NM 80/16A/D-ITT	250	200	-	202.5	-	615	340	-	-	1200	-	-	-	712
BS2V 2 NM 80/20B-ITT	250	200	989	202.5	1841	678	360	1450	1283	1200	1100	1700	840	-
BS2V 2 NM 80/25E-ITT	250	200	-	202.5	-	670	360	-	-	1200	-	-	-	-
BS2V 2 NM 100/20E/A-ITT	300	250	1083	222.5	-	770	410	1490	-	1200	1200	1835	-	-
BS2V 2 NM 100/20D-ITT	300	250	1083	222.5	-	770	410	1490	-	1200	1200	1835	-	1079

Non-binding dimensions to be checked when ordering  
Missing dimensions on request

# BS, NM, NMD



## Dimensions and weights

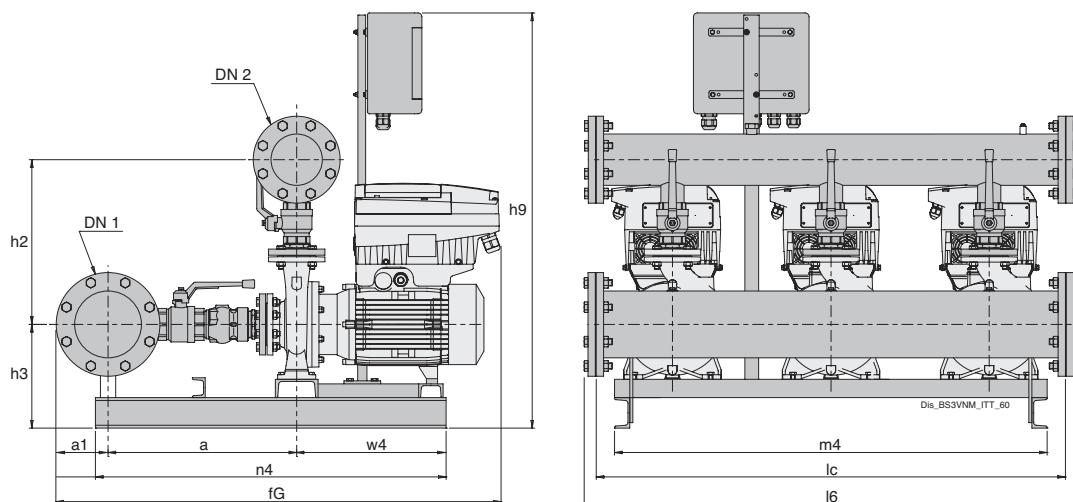

TYPE	Manifolds		mm											Kg Weight
	DN1	DN2	a	a1	fG	h2	h3	h9	l6	lc	m4	n4	w4	
BS3V 3 NM 32/16B/A-ITT	100	80	400	110	923	392	310	1189	1016	950	1000	476	340	-
BS3V 3 NM 32/16A/B-ITT	100	80	400	110	923	392	310	1189	1016	950	1000	476	340	-
BS3V 3 NM 32/20D/B-ITT	100	80	400	110	923	392	310	1189	1016	950	1000	476	340	-
BS3V 3 NM 32/20C/A-ITT	100	80	400	110	923	392	310	1189	1016	950	1000	476	340	274.5
BS3V 3 NM 32/20A/B-ITT	100	80	400	110	923	392	310	1189	1016	950	1000	476	340	-
BS3V 3 NM 32L/16B-ITT	125	100	500	125	1263	400	292	985	1515	1440	1400	1030	558	1240
BS3V 3 NM 32L/16A-ITT	125	100	500	125	1263	400	292	985	1515	1440	1400	1030	558	1240
BS3V 3 NM 32L/20B-ITT	125	100	500	125	1263	400	292	985	1515	1440	1400	1030	558	1240
BS3V 3 NM 32L/20A-ITT	125	100	500	125	1263	400	292	985	1515	1440	1400	1030	558	1240
BS3V 3 NM 40/16C/C-ITT	125	100	500	125	1263	400	292	985	1515	1440	1400	1100	558	-
BS3V 3 NM 40/16B/B-ITT	125	100	500	125	1263	400	292	985	1515	1440	1400	1100	558	362
BS3V 3 NM 40/16A/C-ITT	125	100	500	125	1263	400	292	897	1515	1440	1400	1100	558	-
BS3V 3 NM 40/20D/B-ITT	125	100	520	125	1283	420	320	897	1515	1440	1400	1100	558	-
BS3V 3 NM 40/20C/B-ITT	125	100	500	125	1283	400	292	985	1515	1440	1400	1100	558	-
BS3V 3 NM 40/20B/A-ITT	125	100	520	125	1283	420	320	897	1515	1440	1400	1100	558	-
BS3V 3 NM 40/20AR/A-ITT	125	100	520	125	1283	420	320	897	1515	1440	1400	1100	558	-
BS3V 3 NM 40/20A/A-ITT	125	100	520	125	1283	420	320	897	1515	1440	1400	1100	558	-
BS3V 3 NM 40/25C/C-ITT	125	100	520	125	1330	465	340	977	1515	1440	1400	1030	558	-
BS3V 3 NM 40/25B/C-ITT	125	100	520	125	1330	465	340	1175	1515	1440	1400	1030	558	-
BS3V 3 NM 40/25A/C-ITT	125	100	520	125	1330	465	340	977	1515	1440	1400	1100	558	-
BS3V 3 NM 50/16B/B-ITT	150	125	525	142.5	1653	448	315	977	1515	1440	1400	1430	558	-
BS3V 3 NM 50/16A/B-ITT	150	125	525	142.5	1653	530	315	1175	1515	1440	1400	1430	558	635.5
BS3V 3 NM 50/20B/C-ITT	150	125	525	142.5	1653	468	315	977	1515	1440	1400	1430	558	-
BS3V 3 NM 50/20A/C-ITT	150	125	525	142.5	1653	468	315	977	1515	1440	1400	1430	558	786
BS3V 3 NM 50/20S/C-ITT	150	125	525	142.5	1653	468	315	977	1515	1440	1400	1430	558	-
BS3V 3 NM 50/25C/C-ITT	150	125	525	142.5	1653	493	340	977	1515	1440	1400	1430	558	-
BS3V 3 NM 50/25B/C-ITT	150	125	830	142.5	1688	575	340	1855	1515	1440	1400	1430	563	952
BS3V 3 NM 50/25A/D-ITT	150	125	830	142.5	1688	575	340	1855	1515	1440	1400	1430	563	-
BS3V 3 NM 65/16D/B-ITT	250	200	-	202.5	-	-	-	-	-	1540	-	-	-	-
BS3V 3 NM 65/16C/C-ITT	250	200	-	202.5	-	-	-	-	-	1540	-	-	-	-
BS3V 3 NM 65/16B/C-ITT	250	200	-	202.5	-	-	-	-	-	1540	-	-	-	-
BS3V 3 NM 65/16AR-ITT	250	200	-	202.5	-	-	-	-	-	1540	-	-	-	-
BS3V 3 NM 65/16A/C-ITT	250	200	-	202.5	-	-	-	-	-	1540	-	-	-	-
BS3V 3 NM 65/20C/C-ITT	250	200	-	202.5	-	-	-	-	-	1540	-	-	-	-
BS3V 3 NM 65/20B/D-ITT	250	200	-	202.5	-	-	-	-	-	1900	-	-	-	-
BS3V 3 NM 65/20A/A-ITT	250	200	-	202.5	-	-	-	-	-	1900	-	-	-	1240
BS3V 3 NM 65/25C/A-ITT	250	200	-	202.5	-	-	-	-	-	1900	-	-	-	-
BS3V 3 NM 80/16E/B-ITT	300	250	-	222.5	-	-	-	-	-	1900	-	-	-	-
BS3V 3 NM 80/16D/C-ITT	300	250	-	222.5	-	-	-	-	-	1900	-	-	-	-
BS3V 3 NM 80/16C/C-ITT	300	250	-	222.5	-	-	-	-	-	1900	-	-	-	-
BS3V 3 NM 80/16B/C-ITT	300	250	-	222.5	-	-	-	-	-	1900	-	-	-	-
BS3V 3 NM 80/16A/D-ITT	300	250	1015	222.5	2035	700	390	1985	1983	1900	1850	1830	650	-
BS3V 3 NM 80/20B-ITT	300	250	-	222.5	-	-	-	-	-	1900	-	-	-	-
BS3V 3 NM 80/25E-ITT	300	250	-	222.5	-	-	-	-	-	1900	-	-	-	-
BS3V 3 NM 100/20E/A-ITT	350	300	-	252.5	-	-	-	-	-	1900	-	-	-	-
BS3V 3 NM 100/20D-ITT	350	300	-	252.5	-	-	-	-	-	1900	-	-	-	-

Non-binding dimensions to be checked when ordering  
Missing dimensions on request



Pressure boosting plants with 1 to 3 fixed or variable horizontal multi-stage pumps (INVERTER)

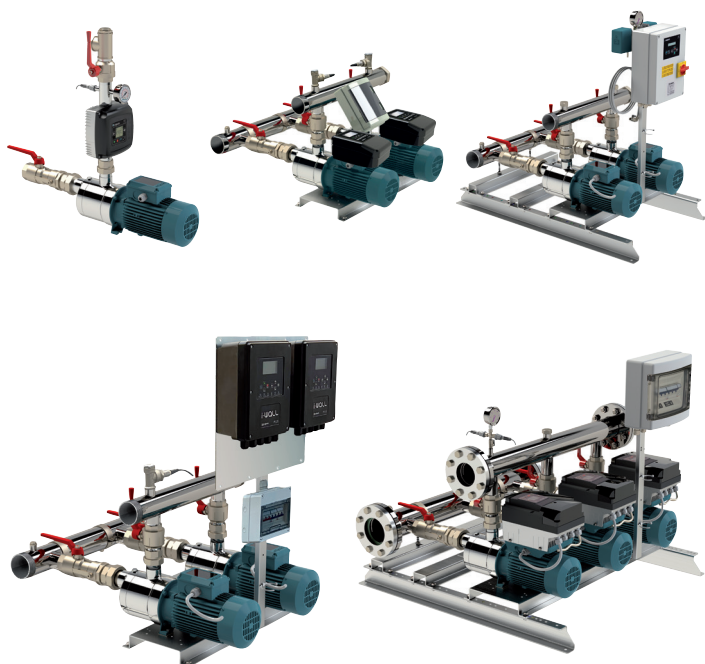

### Fixed speed units

BS 2-6F Pressure boosting sets with 2 to 6 fixed speed pump.  
Sets with 4,5 and 6 pumps on request.  
Depending on the reduction of the pressure in the system, the pressure switches (pressure transducer for 3-pump sets) determine the starting up of the pumps in sequence and the microprocessor alternates the starts.

### Variable speed units with I-MAT

BS2-3V Pressure boosting sets with 2 to 3 variable speed pumps (with I-MAT).  
Depending on water consumption, one or more pumps are activated, all at variable speed, in order to guarantee the quantity of water required at the set pressure.

### Variable speed units with EASYMAT

BS1-3V Pressure boosting sets with 1 to 3 variable speed pumps (with EASYMAT).  
Depending on water consumption, one or more pumps are activated, all at variable speed, in order to guarantee the quantity of water required at the set pressure.

### Variable speed pump units with EASYMAT2

BS2V Pressure boosting sets with 2 variable speed pumps with EASYMAT2.  
Depending on water consumption, one or more pumps are activated, all at variable speed, in order to guarantee the quantity of water required at the set pressure.

### Variable speed pump units with WALL

BS2V Pressure boosting sets with 2 variable speed pumps with WALL.  
Depending on water consumption, one or more pumps are activated, all at variable speed, in order to guarantee the quantity of water required at the set pressure.

### Coverage chart

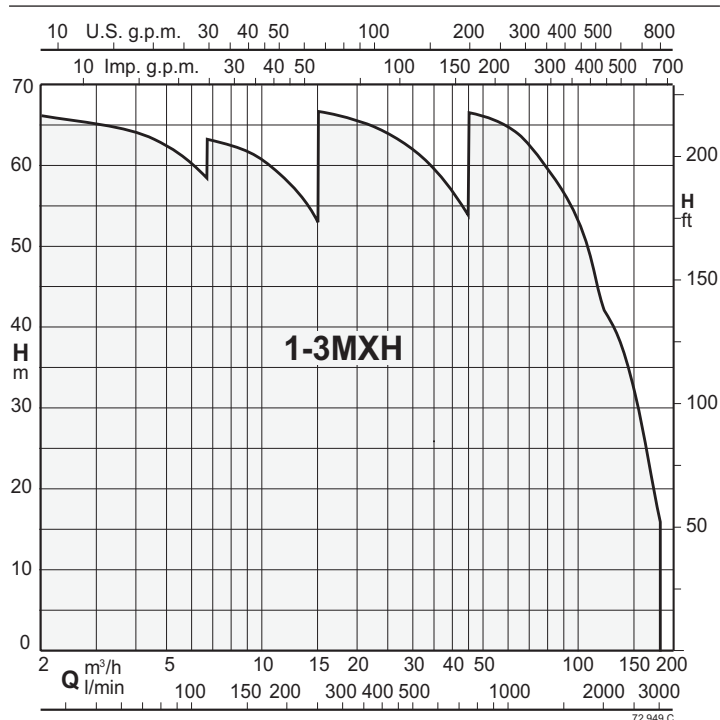

### Construction

Automatic pressure boosting plant consisting of 1 to 6 vertical multistage pumps complete with ball, non return valve on the suction side and ball valves on the delivery side.  
Suction and delivery manifolds for boosting sets with 2,3 pumps in stainless steel AISI 304.  
Connections are located on the delivery manifold for the installation of vessels G1 connection.  
Electrical control boards:

- with microprocessor for fixed speed pump units. Motor starting is D.O.L. up to 5,5 kW and Y/Δ for power rating 7,5 kW.
- - with frequency converter for variable speed pump units.

The unit includes one pressure gauge and three adjustable differential pressure switches or pressure transducer.

### Applications

To supply water in civil and industrial buildings.  
For increasing network pressure (follow local specifications).

### Motor

2-pole induction motors, 50 Hz,  $n \approx 2900$  1/min, set up for inverter operation.  
Three-phase 230/400V  $\pm 10\%$  up to a 3 kW,  
set up for inverter operation;  
400/690  $\pm 10\%$  da 4 a 7,5 kW,  
set up for inverter operation.  
Single-phase 230 V  $\pm 10\%$   
Insulation class F.  
Protection IP54  
Constructed in accordance with: IEC 60034.  
Other voltages and frequencies on request.

### Vessels on request

When installing the unit, connect in the delivery section to a diaphragm or galvanised tank.  
The recommended sized are shown in the following page.

### Special features on request

Pressure unit with 4, 5 and 6 pumps



## Characteristic curves

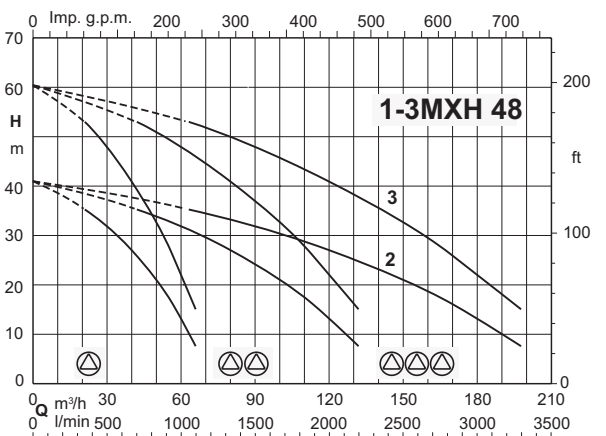
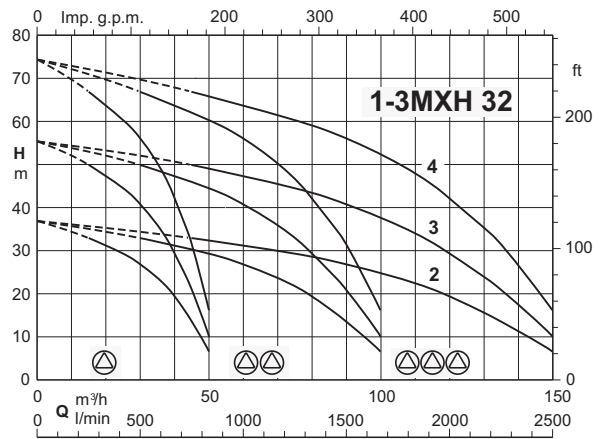
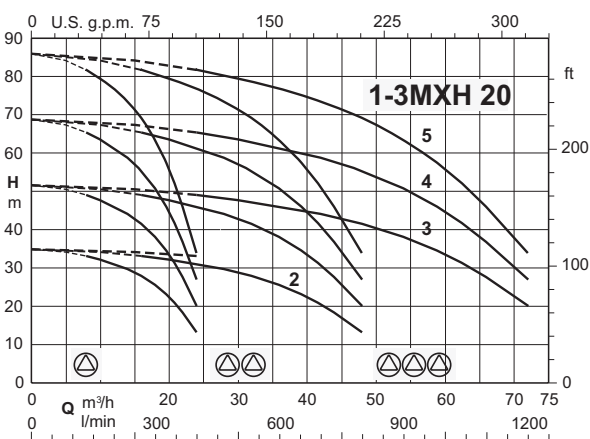
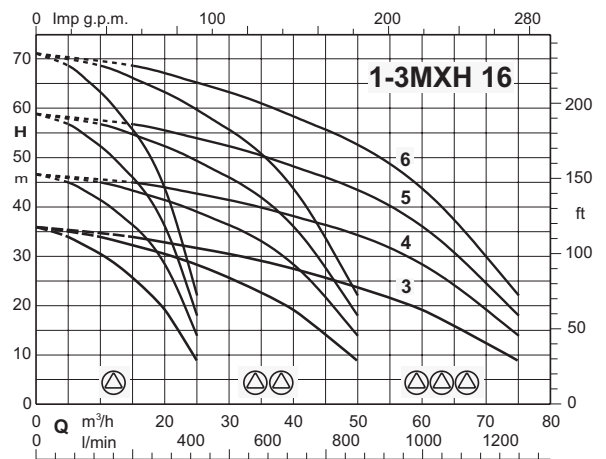
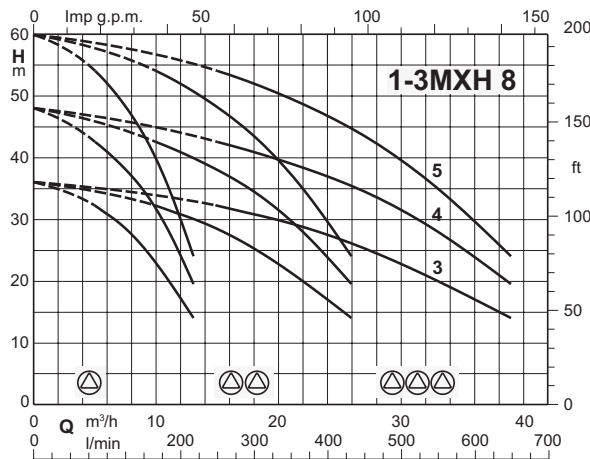
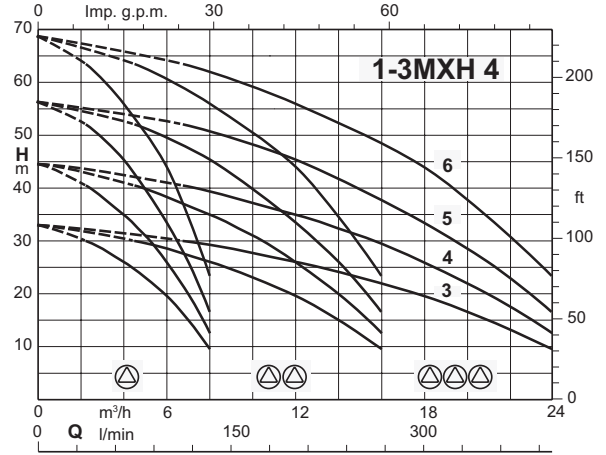
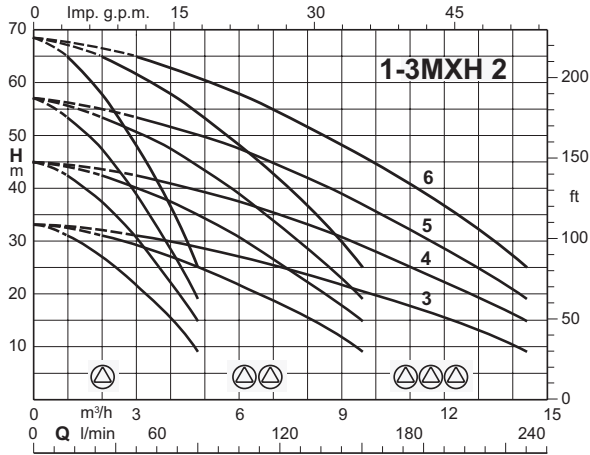

BS, MXH



## Fixed speed pump units

## BS2F

Model	P2 kW	Pressure switch		Tank	
		1	2	membrane	Vessel
		Start/Stop		litri	
		bar			
BS2F 2 MXH 203E	0.37 X2	2 - 2.8	1.7 - 2.5	24X2	100
BS2F 2 MXH 204/A	0.55 X2	3 - 3.9	2.7 - 3.6	24X2	100
BS2F 2 MXH 205/B	0.75 X2	3.3 - 4.9	3.1 - 4.6	24X2	100
BS2F 2 MXH 206/C	1.1 X2	4.3 - 5.9	4 - 5.6	60	100
BS2F 2 MXH 403/A	0.55 X2	1.9 - 2.7	1.6 - 2.4	80	200
BS2F 2 MXH 404/B	0.75 X2	2.9 - 3.7	2.6 - 3.4	100	200
BS2F 2 MXH 405/C	1.1 X2	3.2 - 4.7	2.9 - 4.4	100	200
BS2F 2 MXH 406/A	1.5 X2	4.1 - 5.7	3.8 - 5.4	150	200
BS2F 2 MXH 803/A	1.1 X2	2.1 - 2.9	1.8 - 2.6	200	500
BS2F 2 MXH 804/A	1.5 X2	3 - 3.9	2.7 - 3.6	300	500
BS2F 2 MXH 805/B	1.8 X2	3.4 - 4.9	3.1 - 4.6	300	500
BS2F 2 MXH 1602/A	1.5 X2	0.6 - 2.1	0.3 - 1.8	300	800
BS2F 2 MXH 1603/B	1.8 X2	2.3 - 3.1	2 - 2.8	300	800
BS2F 2 MXH 1604/A	3 X2	3.3 - 4.2	3 - 3.9	500	1000
BS2F 2 MXH 1605/B	3.7 X2	3.7 - 5.2	3.4 - 4.9	500	1000
BS2F 2 MXH 1606/B	4 X2	4.5 - 6.2	4.2 - 5.9	500	1000
BS2F 2 MXH 2002/A	1.8 X2	2.1 - 2.9	1.8 - 2.6	500	1000
BS2F 2 MXH 2003	3 X2	3 - 4.5	2.7 - 4.2	500	800
BS2F 2 MXH 2004/A	4 X2	4.3 - 5.9	4 - 5.6	500	1000
BS2F 2 MXH 2005	5.5 X2	5.5 - 7.4	5.3 - 7.1	750	1500
BS2F 2 MXH-F 3202/B	4 X2	2.2 - 3	1.9 - 2.7	1000	2000
BS2F 2 MXH-F 3203/A	5.5 X2	3.1 - 4.6	2.8 - 4.3	1000	2000
BS2F 2 MXH-F 3204/A	7.5 X2	4.4 - 6.1	4.1 - 5.8	1500	3000
BS2F 2 MXH-F 4802/A	5.5 X2	2.4 - 3.2	2.1 - 2.9	1500	3000
BS2F 2 MXH-F 4803/A	7.5 X2	3.3 - 4.8	3 - 4.5	1500	3000

400V 3~ power supply / 400V 3~ motor

Start and stop pressure controlled by pressure switches

## BS3F

Model	P2 kW	Transducer	Tank	
		1	membrane	Vessel
		Start/Stop		
		bar		litri
BS3F 3 MXH 203E	0.37 X3	2 - 2.8	24X2	100
BS3F 3 MXH 204/A	0.55 X3	2.9 - 3.8	24X2	100
BS3F 3 MXH 205/B	0.75 X3	3.3 - 4.8	24X2	100
BS3F 3 MXH 206/C	1.1 X3	4.2 - 5.9	60	100
BS3F 3 MXH 403/A	0.55 X3	1.9 - 2.7	80	200
BS3F 3 MXH 404/B	0.75 X3	2.8 - 3.6	100	200
BS3F 3 MXH 405/C	1.1 X3	3.2 - 4.7	100	200
BS3F 3 MXH 406/A	1.5 X3	4 - 5.7	150	200
BS3F 3 MXH 803/A	1.1 X3	2.1 - 2.9	200	500
BS3F 3 MXH 804/A	1.5 X3	2.9 - 3.8	300	500
BS3F 3 MXH 805/B	1.8 X3	3.4 - 4.9	300	500
BS3F 3 MXH 1602/A	1.5 X3	0.6 - 2.1	300	800
BS3F 3 MXH 1603/B	1.8 X3	2.2 - 3	300	800
BS3F 3 MXH 1604/A	3 X3	3.3 - 4.2	500	1000
BS3F 3 MXH 1605/B	3.7 X3	3.6 - 5.2	500	1000
BS3F 3 MXH 1606/B	4 X3	4.4 - 6.1	500	1000
BS3F 3 MXH 2002/A	1.8 X3	2.1 - 2.9	500	1000
BS3F 3 MXH 2003	3 X3	3.4 - 4.3	500	800
BS3F 3 MXH 2004/A	4 X3	4.1 - 5.8	500	1000
BS3F 3 MXH 2005	5.5 X3	5.4 - 7.3	750	1500
BS3F 3 MXH-F 3202/B	4 X3	2.1 - 2.9	1000	2000
BS3F 3 MXH-F 3203/B	5.5 X3	2.9 - 4.4	1000	2000
BS3F 3 MXH-F 3204/A	7.5 X3	4.3 - 6	1500	3000
BS3F 3 MXH-F 4802/A	5.5 X3	2.3 - 3.1	1500	3000
BS3F 3 MXH-F 4803/A	7.5 X3	3.2 - 4.7	1500	3000

400V 3~ power supply / 400V 3~ motor

Start and stop pressure controlled by a pressure transducer

## BSM2F

Model	P2 kW	Pressure switch		Tank	
		1	2	membrane	Vessel
		Start/Stop		litri	
		bar			
BSM2F 2 MXHM 203E	0.37 X2	2 - 2.8	1.7 - 2.5	24X2	100
BSM2F 2 MXHM 204/A	0.55 X2	3 - 3.9	2.7 - 3.6	24X2	100
BSM2F 2 MXHM 205/A	0.75 X2	3.3 - 4.9	3.1 - 4.6	24X2	100
BSM2F 2 MXHM 206	1.1 X2	4.3 - 5.9	4 - 5.6	60	100
BSM2F 2 MXHM 403/A	0.55 X2	1.9 - 2.7	1.6 - 2.4	80	200
BSM2F 2 MXHM 404/A	0.75 X2	2.9 - 3.7	2.6 - 3.4	100	200
BSM2F 2 MXHM 405	1.1 X2	3.2 - 4.7	2.9 - 4.4	100	200
BSM2F 2 MXHM 406	1.5 X2	4.1 - 5.7	3.8 - 5.4	150	200
BSM2F 2 MXHM 803	1.1 X2	2.1 - 2.9	1.8 - 2.6	200	500
BSM2F 2 MXHM 804	1.5 X2	3 - 3.9	2.7 - 3.6	300	500

230V 1~ power supply / 230V 1~ motor

Start and stop pressure controlled by pressure switches

BS, MXH



## Variable speed pump units with frequency converter

## BSM1V ..-EMT

Model	P2	voltage	
		Mains Voltage	Motor
		1 ~230 V	3 ~230 V
	kW	A	bar
BSM1V 1 MXH 204/A-EMT	0.55	6,3	2,8
BSM1V 1 MXH 205/B-EMT	0.75	7,4	3,5
BSM1V 1 MXH 206/C-EMT	1.1	10,6	4,6
BSM1V 1 MXH 403/A-EMT	0.55	6,3	2,8
BSM1V 1 MXH 404/B-EMT	0.75	7,4	3,5
BSM1V 1 MXH 405/C-EMT	1.1	10,6	4,6
BSM1V 1 MXH 406/A-EMT	1.5	14,6	6,2
BSM1V 1 MXH 803/A-EMT	1.1	10,6	4,6
BSM1V 1 MXH 804/A-EMT	1.5	14,6	6,2
BSM1V 1 MXH 805/B-EMT	1.8	17,6	8,3
BSM1V 1 MXH 1603/B-EMT	1.8	17,6	8,3

## BSM1V ..-EMM

Model	P2
	kW
BSM1V 1 MXHM 204/A-EMM	0.55
BSM1V 1 MXHM 205/A-EMM	0.75
BSM1V 1 MXHM 206-EMM	1.1
BSM1V 1 MXHM 403/A-EMM	0.55
BSM1V 1 MXHM 404/A-EMM	0.75
BSM1V 1 MXHM 405-EMM	1.1
BSM1V 1 MXHM 803-EMM	1.1

## BSM2V ..-EMT2

Model	P2
	kW
BSM2V 2 MXH 203E-EMT2	0.37 X2
BSM2V 2 MXH 204/A-EMT2	0.55 X2
BSM2V 2 MXH 205/B-EMT2	0.75 X2
BSM2V 2 MXH 206/C-EMT2	1.1 X2
BSM2V 2 MXH 403/A-EMT2	0.55 X2
BSM2V 2 MXH 404/B-EMT2	0.75 X2
BSM2V 2 MXH 405/C-EMT2	1.1 X2
BSM2V 2 MXH 406/A-EMT2	1.5 X2
BSM2V 2 MXH 803/A-EMT2	1.1 X2
BSM2V 2 MXH 804/A-EMT2	1.5 X2
BSM2V 2 MXH 805/B-EMT2	1.8 X2

## BSM2V ..-EMT

Model	P2	voltage	
		Mains Voltage	Motor
		1 ~230 V	3 ~230 V
	kW	A	bar
BSM2V 2 MXH 204/A-EMT	0.55 X2	6,3 X 2	2,8 X 2
BSM2V 2 MXH 205/B-EMT	0.75 X2	7,4 X 2	3,5 X 2
BSM2V 2 MXH 206/C-EMT	1.1 X2	10,6 X 2	4,6 X 2
BSM2V 2 MXH 403/A-EMT	0.55 X2	6,3 X 2	2,8 X 2
BSM2V 2 MXH 404/B-EMT	0.75 X2	7,4 X 2	3,5 X 2
BSM2V 2 MXH 405/C-EMT	1.1 X2	10,6 X 2	4,6 X 2
BSM2V 2 MXH 406/A-EMT	1.5 X2	14,6 X 2	6,2 X 2
BSM2V 2 MXH 803/A-EMT	1.1 X2	10,6 X 2	4,6 X 2
BSM2V 2 MXH 804/A-EMT	1.5 X2	14,6 X 2	6,2 X 2
BSM2V 2 MXH 805/B-EMT	1.8 X2	17,6 X 2	8,3 X 2
BSM2V 2 MXH 1603/B-EMT	1.8 X2	17,6 X 2	8,3 X 2

## BSM3V ..-EMT

Model	P2	voltage	
		Mains Voltage	Motor
		1 ~230 V	3 ~230 V
	kW	A	bar
BSM3V 3 MXH 203E-EMT	0.37 X3	4,9 X 3	2,4 X 3
BSM3V 3 MXH 204/A-EMT	0.55 X3	6,3 X 3	2,8 X 3
BSM3V 3 MXH 205/B-EMT	0.75 X3	7,4 X 3	3,5 X 3
BSM3V 3 MXH 206/C-EMT	1.1 X3	10,6 X 3	4,6 X 3
BSM3V 3 MXH 403/A-EMT	0.55 X3	6,3 X 3	2,8 X 3
BSM3V 3 MXH 404/B-EMT	0.75 X3	7,4 X 3	3,5 X 3
BSM3V 3 MXH 405/C-EMT	1.1 X3	10,6 X 3	4,6 X 3
BSM3V 3 MXH 406/A-EMT	1.5 X3	14,6 X 3	6,2 X 3
BSM3V 3 MXH 803/A-EMT	1.1 X3	10,6 X 3	4,6 X 3
BSM3V 3 MXH 804/A-EMT	1.5 X3	14,6 X 3	6,2 X 3
BSM3V 3 MXH 805/B-EMT	1.8 X3	17,6 X 3	8,3 X 3
BSM3V 3 MXH 1603/B-EMT	1.8 X3	17,6 X 3	8,3 X 3

## BS2V ..-WALL

Model	P2
	kW
BS2V 2 MXH 405-WALL	0.75 X2
BS2V 2 MXH 406-WALL	1.1 X2
BS2V 2 MXH 805-WALL	1.8 X2

BS, MXH



## Variable speed pump units with frequency converter

## BSM2V ...ITT

Model	P2
	kW
BS2V 2 MXH 204/A-ITT	0.55 X2
BS2V 2 MXH 205/B-ITT	0.75 X2
BS2V 2 MXH 206/C-ITT	1.1 X2
BS2V 2 MXH 403/A-ITT	0.55 X2
BS2V 2 MXH 404/B-ITT	0.75 X2
BS2V 2 MXH 405/C-ITT	1.1 X2
BS2V 2 MXH 406/A-ITT	1.5 X2
BS2V 2 MXH 803/A-ITT	1.1 X2
BS2V 2 MXH 804/A-ITT	1.5 X2
BS2V 2 MXH 805/B-ITT	1.8 X2
BS2V 2 MXH 1603/B-ITT	1.8 X2
BS2V 2 MXH 1604/A-ITT	3 X2
BS2V 2 MXH 1605/B-ITT	3.7 X2
BS2V 2 MXH 1606/B-ITT	4 X2
BS2V 2 MXH 2002/A-ITT	1.8 X2
BS2V 2 MXH 2003-ITT	3 X2
BS2V 2 MXH 2004/A-ITT	4 X2
BS2V 2 MXH 2005-ITT	5.5 X2
BS2V 2 MXH-F 3202/B-ITT	4 X2
BS2V 2 MXH-F 3203/A-ITT	5.5 X2
BS2V 2 MXH-F 3204/A-ITT	7.5 X2
BS2V 2 MXH-F 4802/A-ITT	5.5 X2
BS2V 2 MXH-F 4803/A-ITT	7.5 X2

## BSM3V ...ITT

Model	P2
	kW
BS3V 3 MXH 204/A-ITT	0.55 X3
BS3V 3 MXH 205/B-ITT	0.75 X3
BS3V 3 MXH 206/C-ITT	1.1 X3
BS3V 3 MXH 403/A-ITT	0.55 X3
BS3V 3 MXH 404/B-ITT	0.75 X3
BS3V 3 MXH 405/C-ITT	1.1 X3
BS3V 3 MXH 406/A-ITT	1.5 X3
BS3V 3 MXH 803/A-ITT	1.1 X3
BS3V 3 MXH 804/A-ITT	1.5 X3
BS3V 3 MXH 805/B-ITT	1.8 X3
BS3V 3 MXH 1603/B-ITT	1.8 X3
BS3V 3 MXH 1604/A-ITT	1.8 X3
BS3V 3 MXH 1605/B-ITT	3.7 X3
BS3V 3 MXH 1606/B-ITT	4 X3
BS3V 3 MXH 2002/A-ITT	1.8 X3
BS3V 3 MXH 2003-ITT	3 X3
BS3V 3 MXH 2004/A-ITT	4 X3
BS3V 3 MXH 2005-ITT	5.5 X3
BS3V 3 MXH-F 3202/B-ITT	4 X3
BS3V 3 MXH-F 3203/A-ITT	5.5 X3
BS3V 3 MXH-F 3204/A-ITT	7.5 X3
BS3V 3 MXH-F 4802/A-ITT	5.5 X3
BS3V 3 MXH-F 4803/A-ITT	7.5 X3

## Dimensions and weights

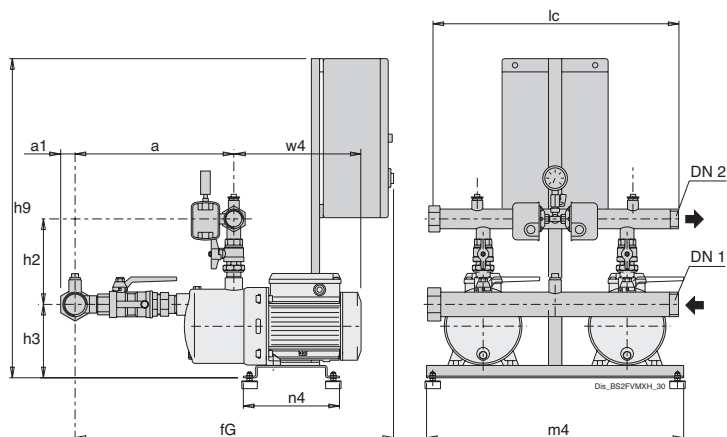

TYPE	Manifolds		mm								Kg Weight
	DN1	DN2	a	fG	h2	h3	h9	lc	m4	n4	
BS2F 2 MXH 203E	G 2	G 1 1/2	323	757	202	162	840	600	625	235	37.1
BS2F 2 MXH 204/A	G 2	G 1 1/2	347	-	202	162	840	600	625	235	42
BS2F 2 MXH 205/B	G 2	G 1 1/2	371	-	202	162	840	600	625	235	47.5
BS2F 2 MXH 206/C	G 2	G 1 1/2	395	829	202	162	840	600	625	235	57.5
BS2F 2 MXH 403/A	G 2	G 1 1/2	323	-	202	162	840	600	625	235	40.7
BS2F 2 MXH 404/B	G 2	G 1 1/2	347	-	202	162	840	600	625	235	-
BS2F 2 MXH 405/C	G 2	G 1 1/2	371	-	202	162	840	600	625	235	53.4
BS2F 2 MXH 406/A	G 2	G 1 1/2	395	-	202	162	840	600	625	235	59.4
BS2F 2 MXH 803/A	G 2 1/2	G 2	386	-	208	162	840	600	625	235	55.6
BS2F 2 MXH 804/A	G 2 1/2	G 2	416	-	208	162	840	600	625	235	60.5
BS2F 2 MXH 805/B	G 2 1/2	G 2	446	-	208	162	840	600	625	235	69

Non-binding dimensions to be checked when ordering  
 Anti-vibration kit supplied disassembled as standard  
 Missing dimensions on request

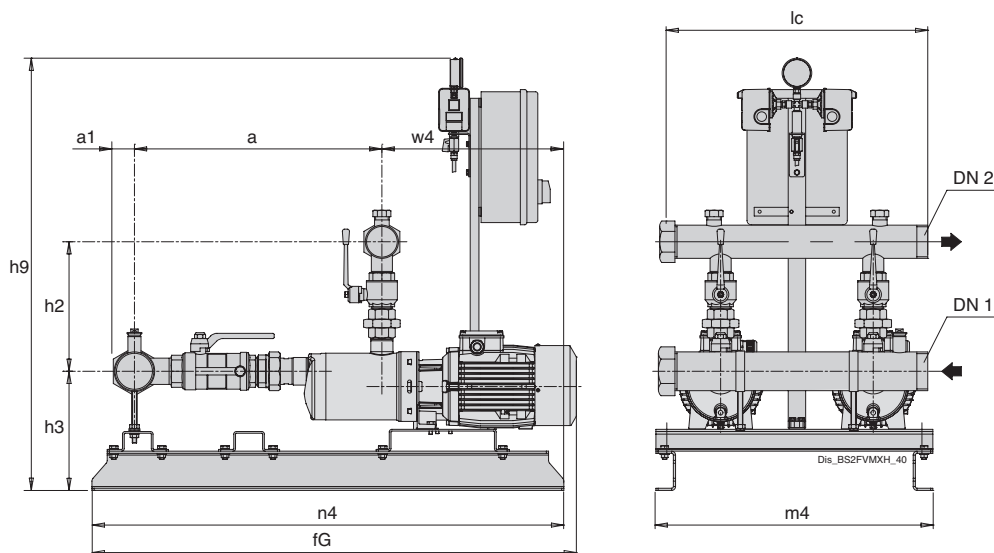

TYPE	Manifolds		mm							Kg Weight
	DN1	DN2	a	h2	h3	h9	lc	m4	n4	
BS2F 2 MXH 1602/A	G 3	G 2 1/2	490	281	258	1040	600	625	1090	94.4
BS2F 2 MXH 1603/B	G 3	G 2 1/2	490	281	258	1040	600	625	1090	101
BS2F 2 MXH 1604/A	G 3	G 2 1/2	530	281	273	1040	600	625	1090	120.3
BS2F 2 MXH 1605/B	G 3	G 2 1/2	565	281	273	1040	600	625	1090	127.5
BS2F 2 MXH 1606/B	G 3	G 2 1/2	605	281	273	1040	600	625	1090	131
BS2F 2 MXH 2002/A	G 3	G 2 1/2	484	351	220	1040	600	625	1090	107.5
BS2F 2 MXH 2003	G 3	G 2 1/2	503	351	230	1040	600	625	1090	107.5
BS2F 2 MXH 2004/A	G 3	G 2 1/2	537	351	230	1040	600	625	1090	134.5
BS2F 2 MXH 2005	G 3	G 2 1/2	572	351	252	1040	600	625	1090	107.5

Non-binding dimensions to be checked when ordering  
 Missing dimensions on request

## Dimensions and weights

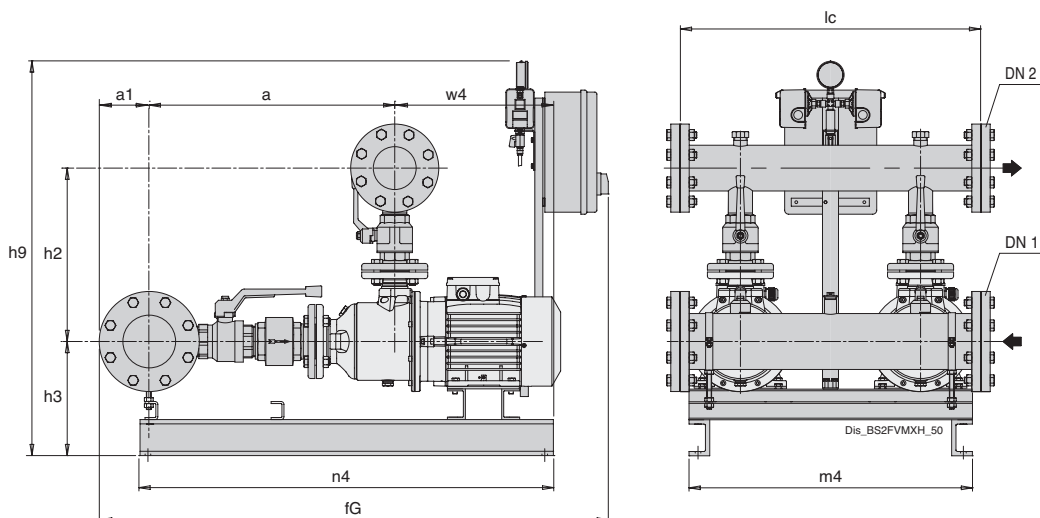

TYPE	Manifolds		mm										Kg Weight
	DN1	DN2	a	fG	h2	h3	h9	l6	lc	m4	n4	w4	
BS2F 2 MXH-F 3202/B	100	80	558	1091	402	298	1510	816	750	750	1175	393	-
BS2F 2 MXH-F 3203/A	100	80	604	1137	402	298	1510	816	750	750	1150	393	230
BS2F 2 MXH-F 3204/A	100	80	650	1183	402	298	1510	816	750	750	1175	393	277
BS2F 2 MXH-F 4802/A	125	100	654	-	402	298	1510	816	750	750	1175	408	107.5
BS2F 2 MXH-F 4803/A	125	100	716	-	402	298	1510	816	750	750	1220	408	230

Non-binding dimensions to be checked when ordering

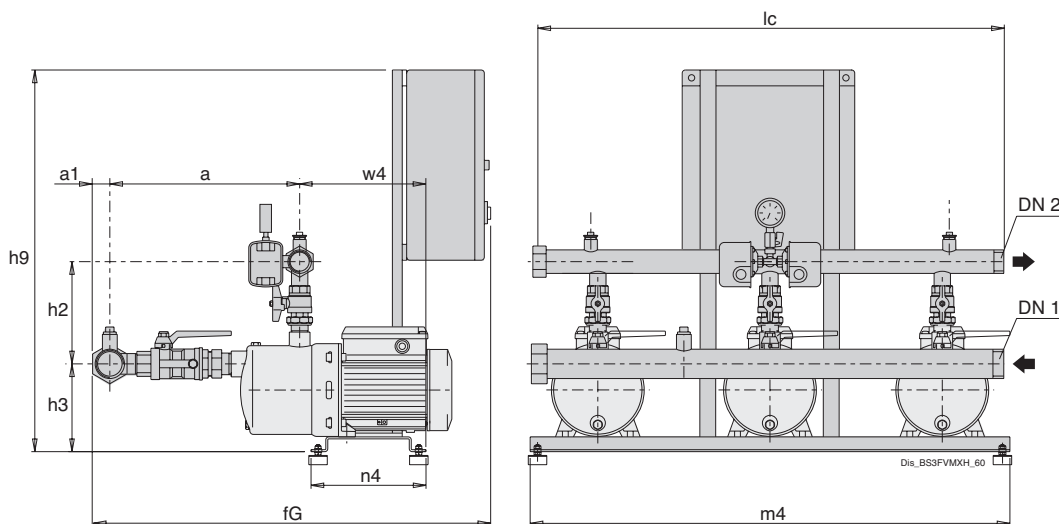

TYPE	Manifolds		mm										Kg Weight
	DN1	DN2	a	a1	h2	h3	h9	lc	m4	n4			
BS3F 3 MXH 203E	G 2 1/2	G 2	335	40	202	178	840	950	1000	305	-		
BS3F 3 MXH 204/A	G 2 1/2	G 2	358	40	202	178	840	950	1000	305	-		
BS3F 3 MXH 205/B	G 2 1/2	G 2	382	40	202	178	840	950	1000	305	76.8		
BS3F 3 MXH 206/C	G 2 1/2	G 2	406	40	202	178	840	950	1000	305	-		
BS3F 3 MXH 403/A	G 2 1/2	G 2	335	40	202	178	840	950	1000	305	-		
BS3F 3 MXH 404/B	G 2 1/2	G 2	358	40	202	178	840	950	1000	305	-		
BS3F 3 MXH 405/C	G 2 1/2	G 2	382	40	202	178	840	950	1000	305	96		
BS3F 3 MXH 406/A	G 2 1/2	G 2	406	40	202	178	840	950	1000	305	102.5		
BS3F 3 MXH 803/A	G 3	G 2 1/2	428	48	208	178	840	950	1000	305	111.5		
BS3F 3 MXH 804/A	G 3	G 2 1/2	458	48	208	178	840	950	1000	305	-		
BS3F 3 MXH 805/B	G 3	G 2 1/2	488	48	208	178	840	950	1000	305	-		

Non-binding dimensions to be checked when ordering  
Anti-vibration kit supplied disassembled as standard

## Dimensions and weights

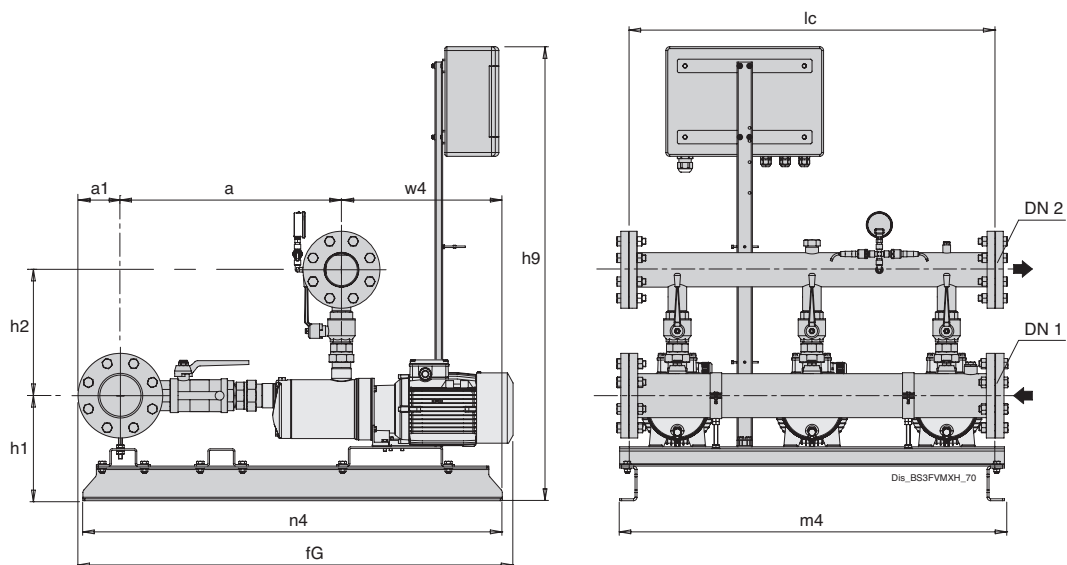

TYPE	Manifolds		mm								Kg Weight
	DN1	DN2	a	a1	h1	h2	h9	lc	m4	n4	
BS3F 3 MXH 1602/A	100	80	500	110	258	327	1060	950	1000	1090	-
BS3F 3 MXH 1603/B	100	80	500	110	258	327	1060	950	1000	1090	-
BS3F 3 MXH 1604/A	100	80	538	110	273	327	1060	950	1000	1090	-
BS3F 3 MXH 1605/B	100	80	575	110	273	327	1060	950	1000	1090	-
BS3F 3 MXH 1606/B	100	80	613	110	273	327	1060	950	1000	1090	228.5
BS3F 3 MXH 2002/A	100	80	499	110	290	398	1060	950	1000	1090	-
BS3F 3 MXH 2003	100	80	518	110	290	398	1060	950	1000	1090	-
BS3F 3 MXH 2004/A	100	80	553	110	290	398	1060	950	1000	1090	-
BS3F 3 MXH 2005	100	80	587	110	252	398	1060	950	1000	1090	-

Non-binding dimensions to be checked when ordering

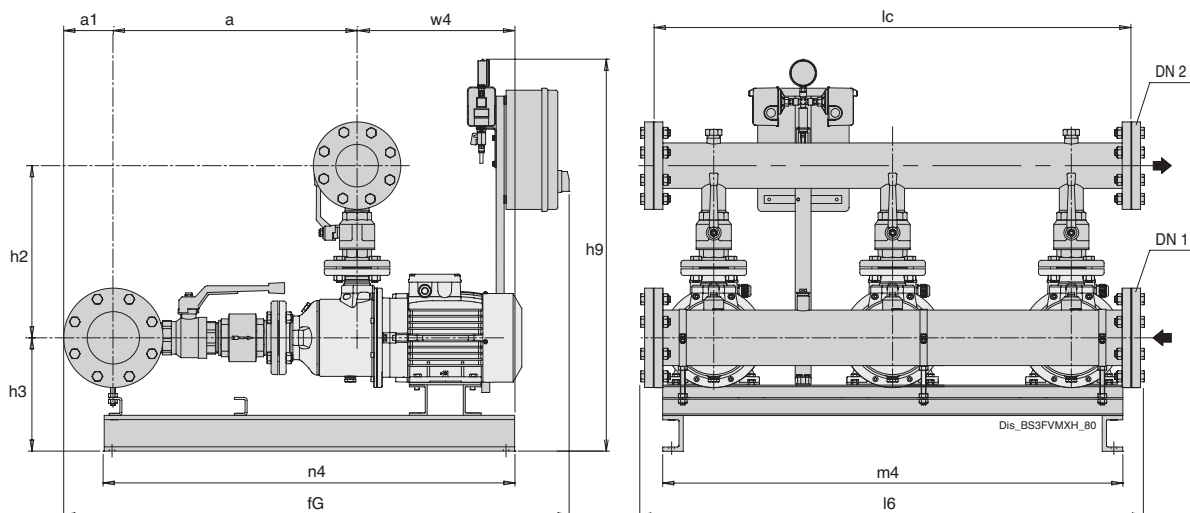

TYPE	Manifolds		mm							
	DN1	DN2	a	a1	h2	h3	h9	lc	m4	n4
BS3F 3 MXH-F 3202/B	125	100	565	125	415	318	1510	1200	1150	1175
BS3F 3 MXH-F 3203/B	125	100	617	125	415	318	1510	1200	1150	1060
BS3F 3 MXH-F 3204/A	125	100	660	125	415	318	1510	1200	1150	1175
BS3F 3 MXH-F 4802/A	150	125	665	142.5	465	318	1510	1200	1150	1175
BS3F 3 MXH-F 4803/A	150	125	725	142.5	465	318	1510	1200	1150	1220

Non-binding dimensions to be checked when ordering

## Dimensions and weights

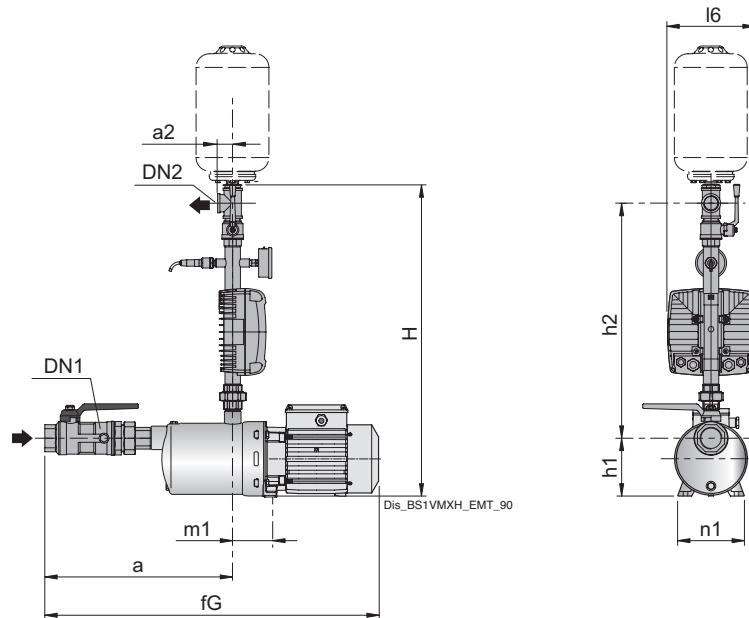

TYPE	Manifolds		mm								Kg Weight
	DN1	DN2	a	fG	H	h1	h2	l6	m1	n1	
BSM1V 1 MXH 203E-EMT	G 1 1/4	G 1	274	511	708	127	516	165	88	146	14
BSM1V 1 MXH 204/A-EMT	G 1 1/4	G 1	298	561	708	127	516	165	88	146	16.8
BSM1V 1 MXH 205/B-EMT	G 1 1/4	G 1	322	585	708	127	516	165	88	146	18.3
BSM1V 1 MXH 206/C-EMT	G 1 1/4	G 1	346	609	708	127	516	165	88	146	23.9
BSM1V 1 MXH 403/A-EMT	G 1 1/4	G 1	274	537	708	127	516	165	88	146	16.1
BSM1V 1 MXH 404/B-EMT	G 1 1/4	G 1	298	561	708	127	516	165	88	146	19
BSM1V 1 MXH 405/C-EMT	G 1 1/4	G 1	322	585	708	127	516	165	88	146	22.1
BSM1V 1 MXH 406/A-EMT	G 1 1/4	G 1	346	680	708	127	516	165	88	146	25.4
BSM1V 1 MXH 803/A-EMT	G 1 1/2	G 1	323	657	708	127	516	165	88	146	23.3
BSM1V 1 MXH 804/A-EMT	G 1 1/2	G 1	353	687	708	127	516	165	88	146	25.1
BSM1V 1 MXH 805/B-EMT	G 1 1/2	G 1	383	717	708	127	516	165	88	146	29.3
BSM1V 1 MXH 1603/B-EMT	G 2	G 1 1/2	404	752	750	117	560	165	101	146	32.8

Non-binding dimensions to be checked when ordering

TYPE	Manifolds		mm								Kg Weight
	DN1	DN2	a	fG	H	h1	h2	l6	m1	n1	
BSM1V 1 MXHM 203E-EMM	G 1 1/4	G 1	274	511	708	127	516	165	88	146	14
BSM1V 1 MXHM 204/A-EMM	G 1 1/4	G 1	298	561	708	127	516	165	88	146	17.6
BSM1V 1 MXHM 205/A-EMM	G 1 1/4	G 1	322	585	708	127	516	165	88	146	18.8
BSM1V 1 MXHM 206-EMM	G 1 1/4	G 1	346	609	708	127	516	165	88	146	24
BSM1V 1 MXHM 403/A-EMM	G 1 1/4	G 1	274	537	708	127	516	165	88	146	16.6
BSM1V 1 MXHM 404/A-EMM	G 1 1/4	G 1	298	561	708	127	516	165	88	146	19
BSM1V 1 MXHM 405-EMM	G 1 1/4	G 1	322	585	708	127	516	165	88	146	24.3
BSM1V 1 MXHM 803-EMM	G 1 1/2	G 1	323	657	708	127	516	165	88	146	24

Non-binding dimensions to be checked when ordering



## Dimensions and weights

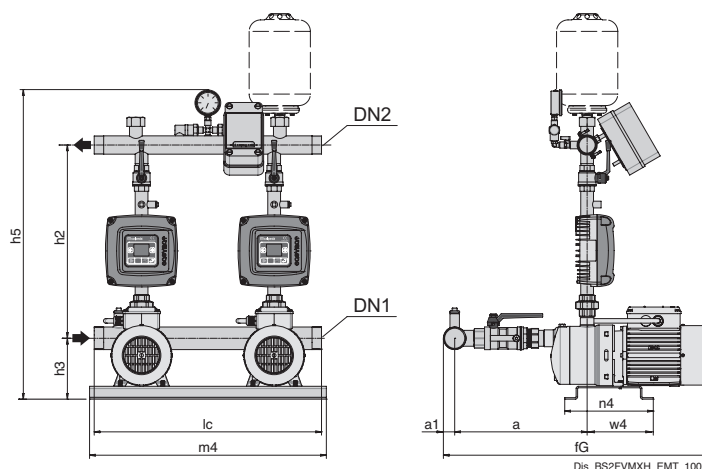

Dis\_BS2FVMXH\_EMT\_100

TYPE	Manifolds		mm										Kg Weight
	DN1	DN2	a	fG	h2	h3	h5	lc	m4	n4	w4		
BSM2V 2 MXH 203E-EMT	G 2	G 1 1/2	323	617	486	162	800	600	625	240	213	37	
BSM2V 2 MXH 204/A-EMT	G 2	G 1 1/2	347	641	486	162	800	600	625	240	213	43.1	
BSM2V 2 MXH 205/B-EMT	G 2	G 1 1/2	371	665	486	162	800	600	625	240	213	49	
BSM2V 2 MXH 206/C-EMT	G 2	G 1 1/2	395	689	486	162	800	600	625	240	213	56.5	
BSM2V 2 MXH 403/A-EMT	G 2	G 1 1/2	323	617	486	162	800	600	625	240	213	42	
BSM2V 2 MXH 404/B-EMT	G 2	G 1 1/2	347	641	486	162	800	600	625	240	213	44.2	
BSM2V 2 MXH 405/C-EMT	G 2	G 1 1/2	371	665	486	162	800	600	625	240	213	54.1	
BSM2V 2 MXH 406/A-EMT	G 2	G 1 1/2	395	689	486	162	800	600	625	240	213	61	
BSM2V 2 MXH 803/A-EMT	G 2 1/2	G 2	386	-	492	162	806	600	625	240	-	55.8	
BSM2V 2 MXH 804/A-EMT	G 2 1/2	G 2	416	-	492	162	806	600	625	240	-	62.7	
BSM2V 2 MXH 805/B-EMT	G 2 1/2	G 2	446	-	492	162	806	600	625	240	-	68.7	
BSM2V 2 MXH 1603/B-EMT	G 3	G 2 1/2	490	1090	563	258	975	600	625	1090	478	102.5	

Non-binding dimensions to be checked when ordering

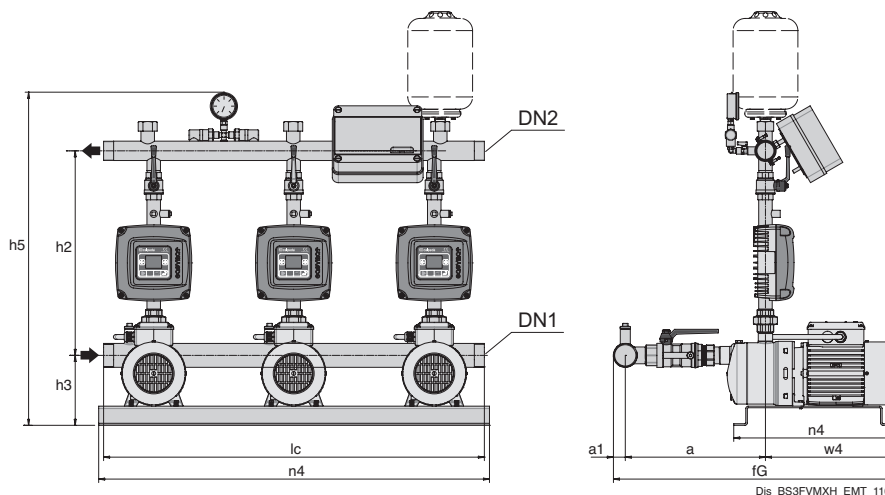

Dis\_BS3FVMXH\_EMT\_110

TYPE	Manifolds		mm										Kg Weight
	DN1	DN2	a	a1	h2	h3	h5	lc	m4	n4			
BSM3V 3 MXH 203E-EMT	G 2 1/2	G 2	331	40	492	178	821	950	1000	305	62.1		
BSM3V 3 MXH 204/A-EMT	G 2 1/2	G 2	355	40	492	178	821	950	1000	305	70.2		
BSM3V 3 MXH 205/B-EMT	G 2 1/2	G 2	379	40	492	178	821	950	1000	305	77.6		
BSM3V 3 MXH 206/C-EMT	G 2 1/2	G 2	403	40	492	178	821	950	1000	305	-		
BSM3V 3 MXH 403/A-EMT	G 2 1/2	G 2	331	40	492	178	821	950	1000	305	67.8		
BSM3V 3 MXH 404/B-EMT	G 2 1/2	G 2	355	40	492	178	821	950	1000	305	78.7		
BSM3V 3 MXH 405/C-EMT	G 2 1/2	G 2	379	40	492	178	821	950	1000	305	89.5		
BSM3V 3 MXH 406/A-EMT	G 2 1/2	G 2	403	40	492	178	821	950	1000	305	-		
BSM3V 3 MXH 803/A-EMT	G 3	G 2 1/2	402	48	512	178	845	950	1000	305	92.3		
BSM3V 3 MXH 804/A-EMT	G 3	G 2 1/2	432	48	512	178	845	950	1000	305	101		
BSM3V 3 MXH 805/B-EMT	G 3	G 2 1/2	462	48	512	178	845	950	1000	305	115		
BSM3V 3 MXH 1603/B-EMT	100	80	498	110	609	258	1136	1000	1000	1090	189		

Non-binding dimensions to be checked when ordering

## Dimensions and weights

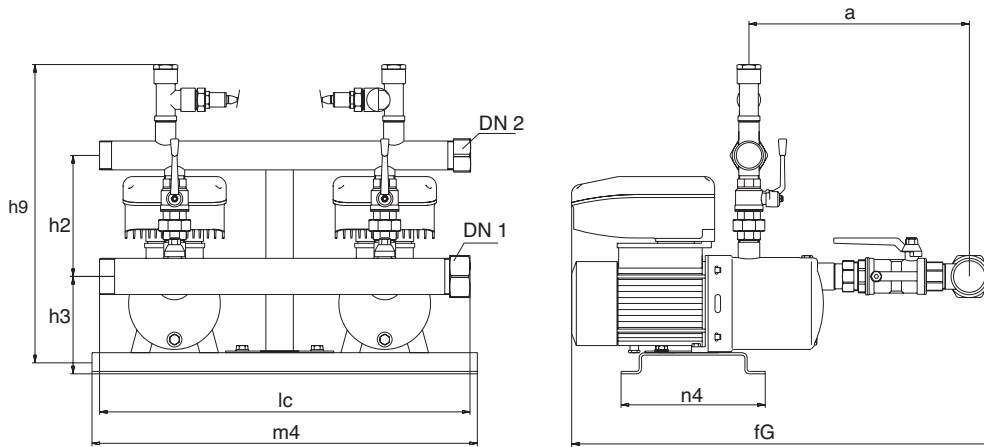

TYPE	Manifolds		mm								Kg Weight
	DN1	DN2	a	fG	h1	h2	h9	lc	m4	n4	
BSM2V 2 MXH 203E-EMT2	G 2	G 1 1/2	343	656	161	242	543	600	625	240	-
BSM2V 2 MXH 204/A-EMT2	G 2	G 1 1/2	367	647	161	242	543	600	625	240	-
BSM2V 2 MXH 205/B-EMT2	G 2	G 1 1/2	391	671	161	242	543	600	625	240	-
BSM2V 2 MXH 206/C-EMT2	G 2	G 1 1/2	415	790	161	242	543	600	625	240	-
BSM2V 2 MXH 403/A-EMT2	G 2	G 1 1/2	367	671	161	242	543	600	625	240	-
BSM2V 2 MXH 404/B-EMT2	G 2	G 1 1/2	367	671	161	242	543	600	625	240	-
BSM2V 2 MXH 405/C-EMT2	G 2	G 1 1/2	391	766	161	242	543	600	625	240	58
BSM2V 2 MXH 406/A-EMT2	G 2	G 1 1/2	415	790	161	242	543	600	625	240	76
BSM2V 2 MXH 803/A-EMT2	G 2 1/2	G 2	430	797	162	252	564	600	625	240	-
BSM2V 2 MXH 804/A-EMT2	G 2 1/2	G 2	460	827	162	252	564	600	625	240	100
BSM2V 2 MXH 805/B-EMT2	G 2 1/2	G 2	460	897	162	252	564	600	625	365	-

Non-binding dimensions to be checked when ordering

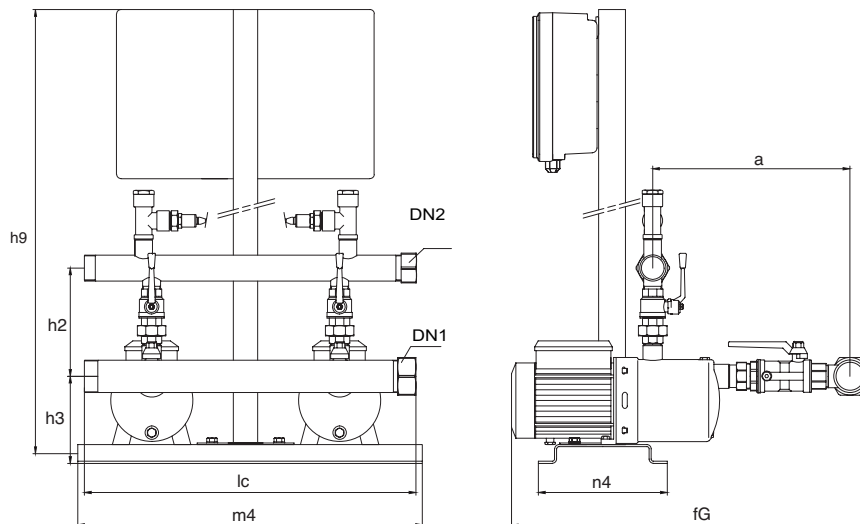

TYPE	Manifolds		mm							
	DN1	DN2	a	fG	h2	h3	h9	lc	m4	n4
BS2V 2 MXH 405-WALL	G 2	G 1 1/2	391	766	242	161	1034	600	625	240
BS2V 2 MXH 406-WALL	G 2	G 1 1/2	415	790	242	161	1034	600	625	240
BS2V 2 MXH 805-WALL	G 2 1/2	G 2	460	897	252	171	1034	600	625	365

Non-binding dimensions to be checked when ordering

## Dimensions and weights

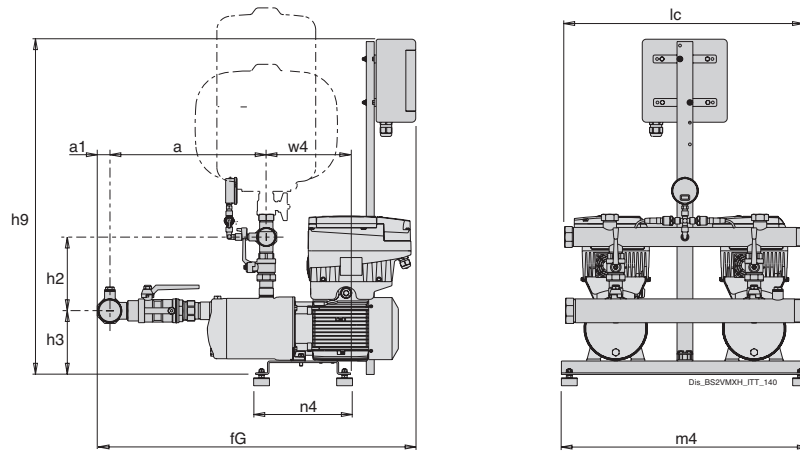

TYPE	Manifolds		mm										Kg Weight
	DN1	DN2	a	a1	fG	h2	h3	h9	lc	m4	n4	w4	
BS2V 2 MXH 204/A-ITT	G 2	G 1 1/2	347	32	758	187	162	848	600	625	235	218	53.2
BS2V 2 MXH 205/B-ITT	G 2	G 1 1/2	371	32	782	187	162	848	600	625	235	218	-
BS2V 2 MXH 206/C-ITT	G 2	G 1 1/2	395	32	806	187	162	848	600	625	235	218	67.7
BS2V 2 MXH 403/A-ITT	G 2	G 1 1/2	323	32	734	187	162	848	600	625	235	220	52
BS2V 2 MXH 404/B-ITT	G 2	G 1 1/2	347	32	758	187	162	848	600	625	235	220	56.7
BS2V 2 MXH 405/C-ITT	G 2	G 1 1/2	371	32	782	187	162	848	600	625	235	220	66.2
BS2V 2 MXH 406/A-ITT	G 2	G 1 1/2	395	32	806	187	162	848	600	625	235	220	69.7
BS2V 2 MXH 803/A-ITT	G 2 1/2	G 2	386	40	797	193	162	848	600	625	235	220	67.4
BS2V 2 MXH 804/A-ITT	G 2 1/2	G 2	416	40	827	193	162	848	600	625	235	220	72.3
BS2V 2 MXH 805/B-ITT	G 2 1/2	G 2	446	40	857	193	162	848	600	625	235	220	80

Non-binding dimensions to be checked when ordering  
 Anti-vibration kit supplied disassembled as standard

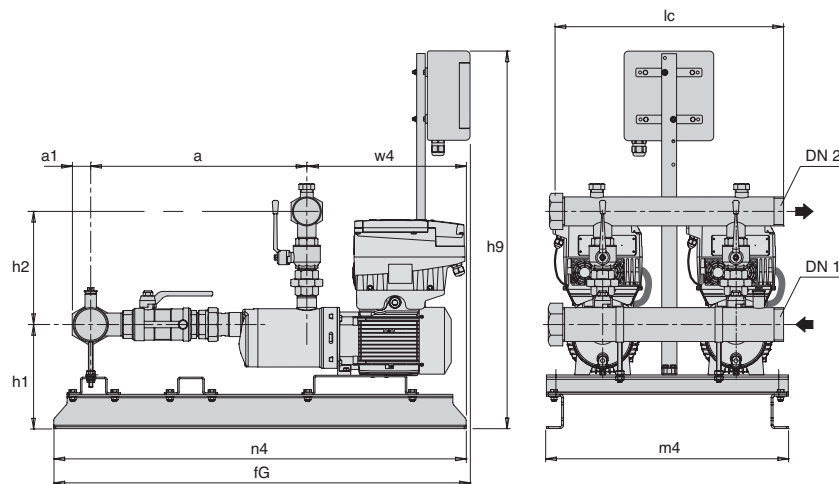

TYPE	Manifolds		mm										Kg Weight
	DN1	DN2	a	a1	fG	h1	h2	h9	lc	m4	n4	w4	
BS2V 2 MXH 1603/B-ITT	G 3	G 2 1/2	490	48	1090	258	283	980	600	625	1090	478	110
BS2V 2 MXH 1604/A-ITT	G 3	G 2 1/2	530	48	1100	273	273	980	600	625	1090	-	133
BS2V 2 MXH 1605/B-ITT	G 3	G 2 1/2	565	48	1133	273	273	980	600	625	1090	-	141.7
BS2V 2 MXH 1606/B-ITT	G 3	G 2 1/2	605	48	1192	273	273	980	600	625	1090	-	143
BS2V 2 MXH 2002/A-ITT	G 3	G 2 1/2	484	48	1170	290	220	980	600	625	1090	-	-
BS2V 2 MXH 2003-ITT	G 3	G 2 1/2	503	48	1170	290	230	980	600	625	1090	-	138.5
BS2V 2 MXH 2004/A-ITT	G 3	G 2 1/2	537	48	1195	290	230	980	600	625	1090	-	147.3
BS2V 2 MXH 2005-ITT	G 3	G 2 1/2	572	48	1245	252	252	980	600	625	1090	-	173

Non-binding dimensions to be checked when ordering

## Dimensions and weights

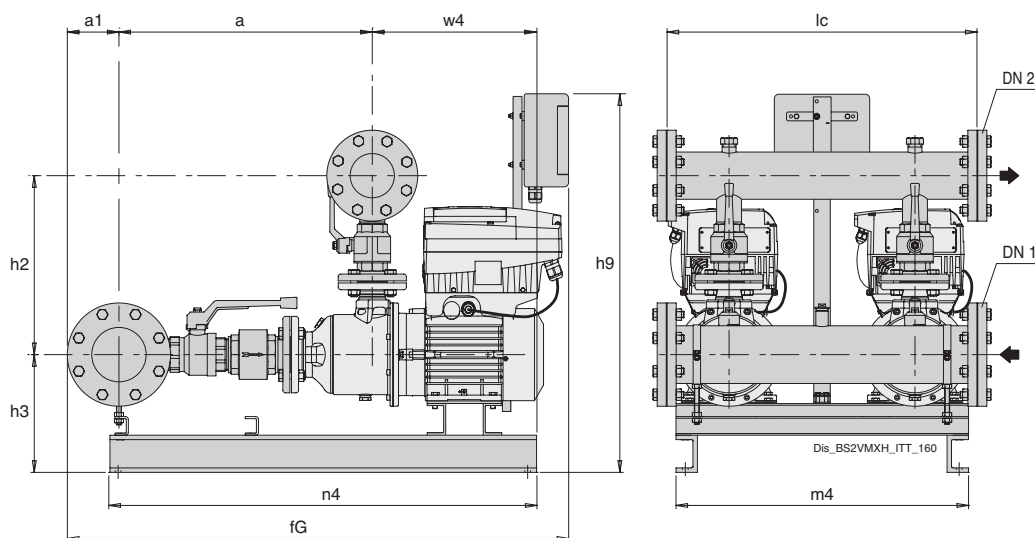

TYPE	Manifolds		mm										Kg
	DN1	DN2	a	a1	fg	h2	h3	h9	lc	m4	n4	Weight	
BS2V 2 MXH-F 3202/B-ITT	100	80	558	110	1180	402	298	1225	750	750	1010	224.8	
BS2V 2 MXH-F 3203/A-ITT	100	80	604	110	1274	402	298	1225	750	750	1050	244	
BS2V 2 MXH-F 3204/A-ITT	100	80	650	110	1320	402	298	1225	750	750	1110	-	
BS2V 2 MXH-F 4802/A-ITT	125	100	654	125	1306	468	298	1225	750	750	1065	-	
BS2V 2 MXH-F 4803/A-ITT	125	100	716	125	1367	468	298	1225	750	750	1110	-	

Non-binding dimensions to be checked when ordering

## Dimensions and weights

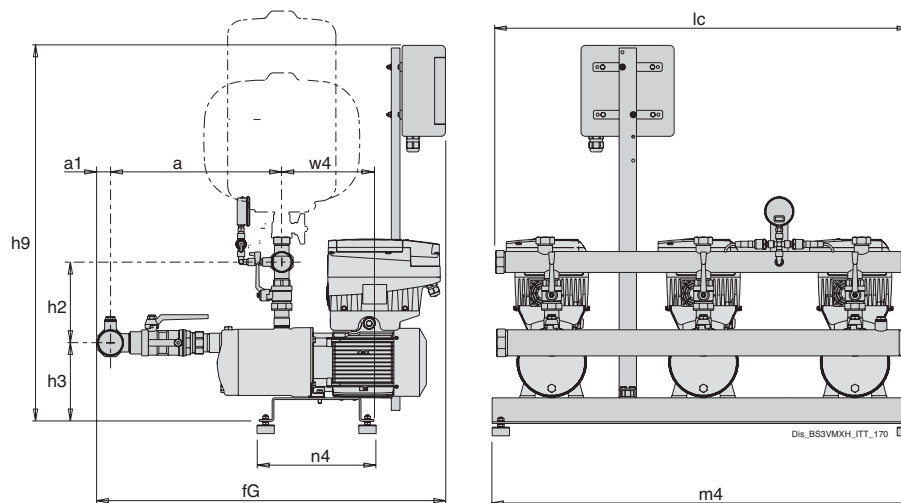

TYPE	Manifolds		mm									Kg Weight
	DN1	DN2	a	a1	fG	h2	h3	h9	lc	m4	n4	
BS3V 3 MXH 204/A-ITT	G 2 1/2	G 2	356	40	857	193	178	913	950	1000	423	-
BS3V 3 MXH 205/B-ITT	G 2 1/2	G 2	380	40	881	193	178	913	950	1000	423	-
BS3V 3 MXH 206/C-ITT	G 2 1/2	G 2	404	40	905	193	178	913	950	1000	423	106
BS3V 3 MXH 403/A-ITT	G 2 1/2	G 2	332	40	833	193	178	913	950	1000	423	-
BS3V 3 MXH 404/B-ITT	G 2 1/2	G 2	356	40	857	193	178	913	950	1000	423	-
BS3V 3 MXH 405/C-ITT	G 2 1/2	G 2	390	40	881	193	178	913	950	1000	423	101.4
BS3V 3 MXH 406/A-ITT	G 2 1/2	G 2	404	40	905	193	178	913	950	1000	423	-
BS3V 3 MXH 803/A-ITT	G 3	G 2 1/2	404	48	905	193	178	913	950	1000	423	-
BS3V 3 MXH 804/A-ITT	G 3	G 2 1/2	432	48	933	193	178	913	950	1000	423	114
BS3V 3 MXH 805/B-ITT	G 3	G 2 1/2	449	48	950	193	178	913	950	1000	423	125.5

Non-binding dimensions to be checked when ordering  
 Anti-vibration kit supplied disassembled as standard

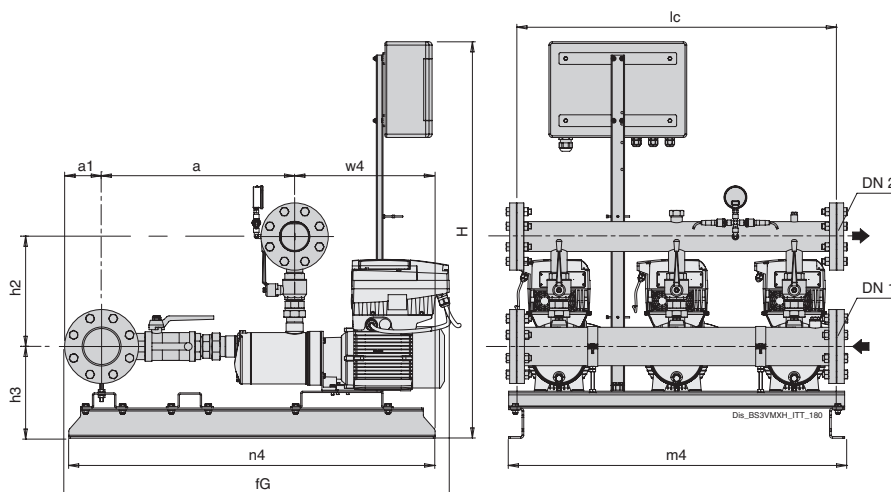

TYPE	Manifolds		mm									Kg Weight
	DN1	DN2	a	a1	fG	h2	h3	h9	lc	m4	n4	
BS3V 3 MXH 1603/B-ITT	100	80	500	110	1100	321	258	980	950	1000	1090	201
BS3V 3 MXH 1604/A-IT	100	80	538	110	1135	321	273	980	950	1000	1090	233
BS3V 3 MXH 1605/B-ITT	100	80	575	110	1171	321	273	980	950	1000	1090	-
BS3V 3 MXH 1606/B-ITT	100	80	613	110	1231	321	273	980	950	1000	1090	250.8
BS3V 3 MXH 2002/A-ITT	100	80	499	110	1170	391	290	980	950	1000	1090	-
BS3V 3 MXH 2003-ITT	100	80	518	110	1170	391	290	980	950	1000	1090	-
BS3V 3 MXH 2004/A-ITT	100	80	553	110	1230	391	290	980	950	1000	1090	-
BS3V 3 MXH 2005-ITT	100	80	587	110	1245	391	252	980	950	1000	1090	-

Non-binding dimensions to be checked when ordering

## Dimensions and weights

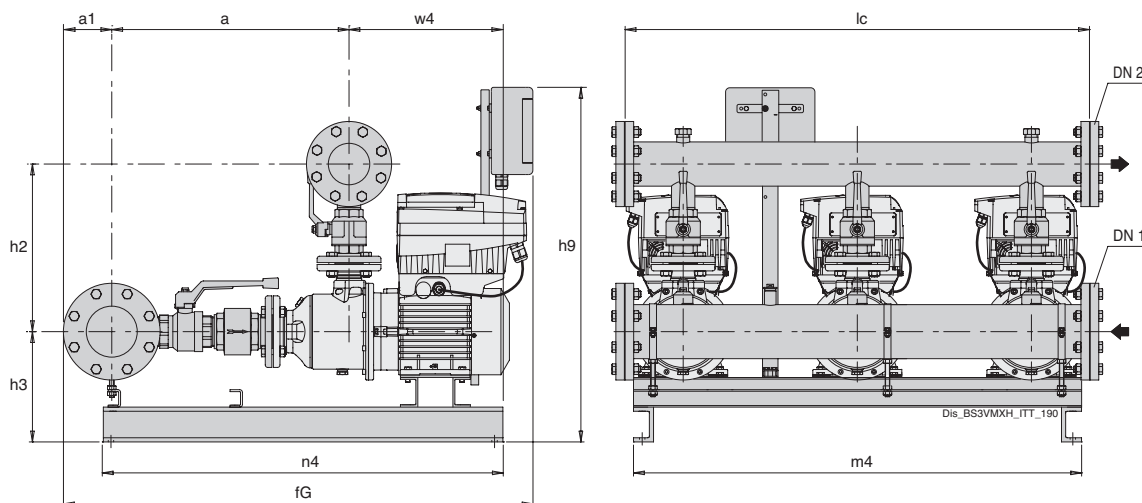

TYPE	Manifolds		mm									Kg Weight
	DN1	DN2	a	a1	fG	h2	h3	h9	lc	m4	n4	
BS3V 3 MXH-F 3202/B-ITT	125	100	571	125	1180	415	318	1246	1200	1150	1065	-
BS3V 3 MXH-F 3203/A-ITT	125	100	617	125	1096	415	318	1246	1200	1150	1060	365
BS3V 3 MXH-F 3204/A-ITT	125	100	663	125	1320	415	318	1246	1200	1150	1110	-
BS3V 3 MXH-F 4802/A-ITT	150	125	668	142.5	1320	480	316	1246	1200	1150	1065	-
BS3V 3 MXH-F 4803/A-ITT	150	125	750	142.5	1381	480	316	1246	1200	1150	1110	-

Non-binding dimensions to be checked when ordering

# BS, MPSU



Pressure units with 1 to 3 multi-stage vertical, fixed or variable speed pumps (INVERTER)



## Fixed speed units

BS 2-6F Pressure boosting sets with 2 to 6 fixed speed pump.  
Sets with 4,5 and 6 pumps on request.  
Depending on the reduction of the pressure in the system, the pressure switches (pressure transducer for 3-pump sets) determine the starting up of the pumps in sequence and the microprocessor alternates the starts.

## Variable speed units with EASYMAT

BS1-3V Pressure boosting sets with 1 to 3 variable speed pumps (with EASYMAT).  
Depending on water consumption, one or more pumps are activated, all at variable speed, in order to guarantee the quantity of water required at the set pressure.

## Construction

Automatic pressure boosting plant consisting of 1 to 6 vertical multistage pumps complete with ball, non return valve on the suction side and ball valves on the delivery side.  
Suction and delivery manifolds for boosting sets with 2,3 pumps in stainless steel AISI 304.  
Connections are located on the delivery manifold for the installation of vessels G1 connection.  
Electrical control boards:

- with microprocessor for fixed speed pump units. Motor starting is D.O.L. up to 5,5 kW and Y/Δ for power rating 7,5 kW.
- - with frequency converter for variable speed pump units.

The unit includes one pressure gauge and three adjustable differential pressure switches or pressure transducer.

## Coverage chart

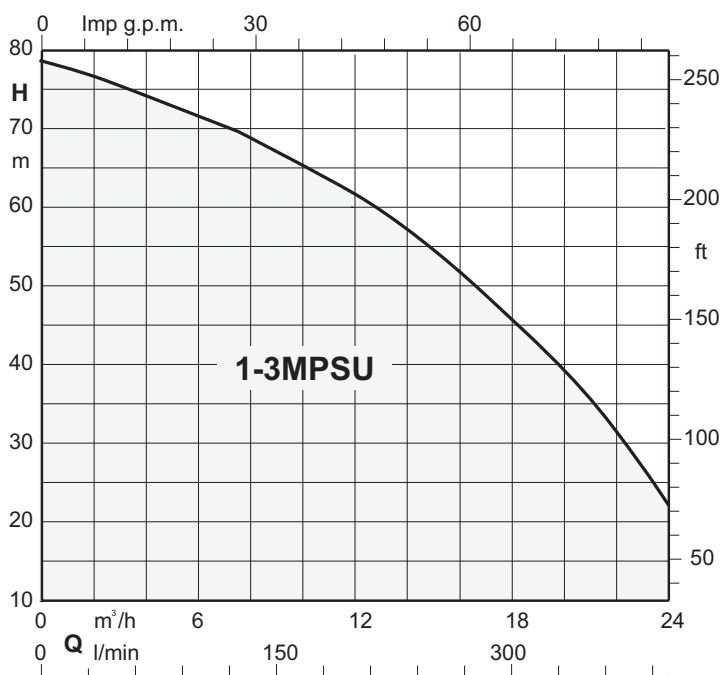

## Applications

To supply water in civil and industrial buildings.  
For increasing network pressure (follow local specifications).

## Motor

2-pole induction motors, 50 Hz,  $n \approx 2900$  1/min.  
Three-phase 230V - 400V  $\pm 10\%$ ;  
Single-phase 230 V  $\pm 10\%$ .  
Insulation class F.  
Protection IP 68.  
Constructed in accordance with IEC 60034.  
Other voltages and frequencies on request.

## Vessels on request

When installing the unit, connect in the delivery section to a diaphragm or galvanised tank.  
The recommended sized are shown in the following page.

## Special features on request

Pressure unit with 4, 5 and 6 pumps



**Characteristic curves**

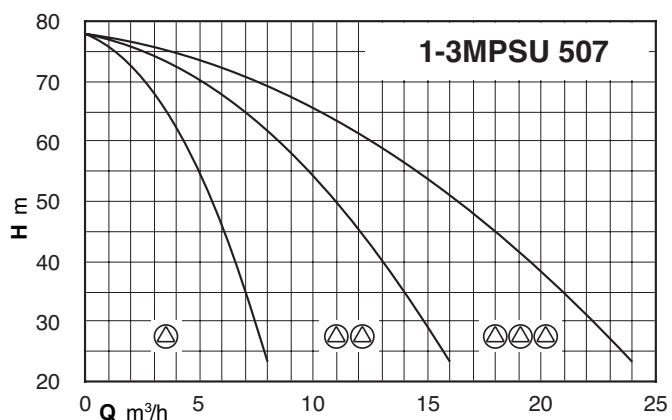
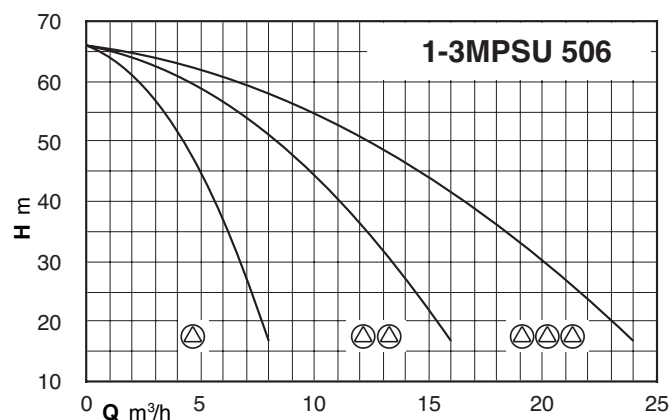
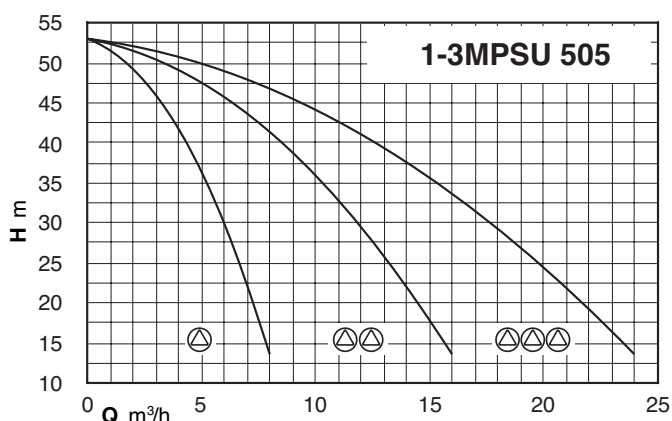
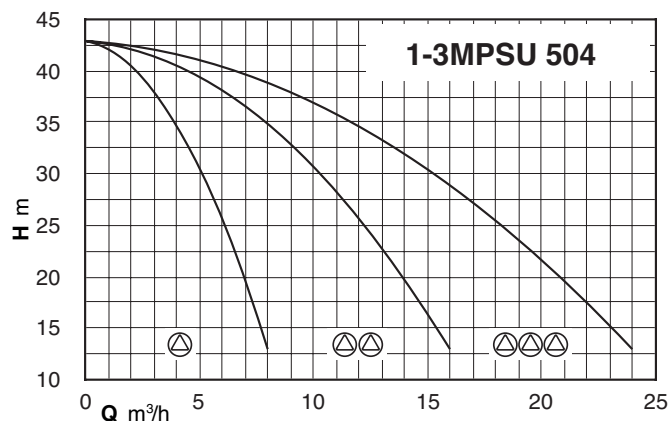
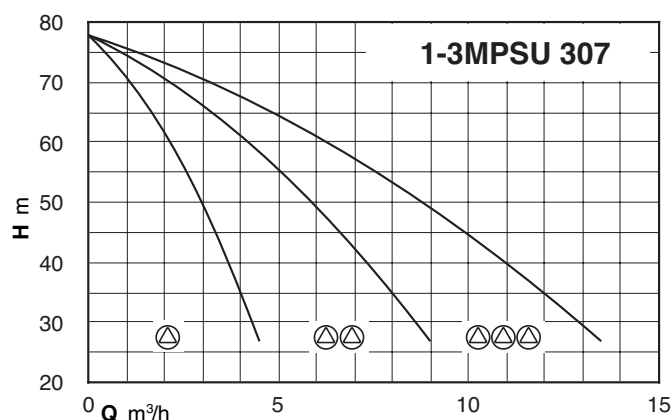
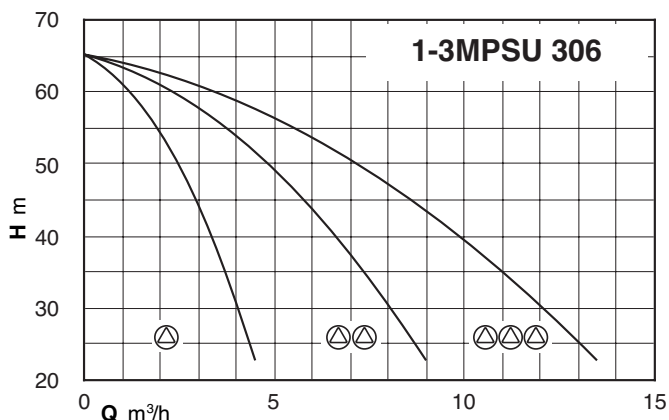
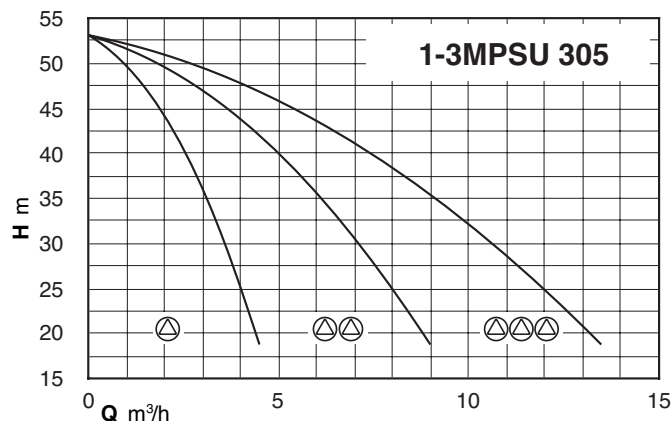
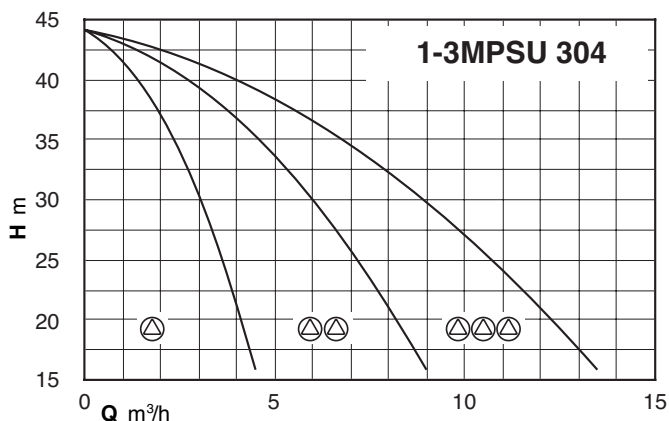

## BS, MPSU



## Fixed speed pump units

## BS2F

		Pressure switch		Tank	
		1	2	membrane	Vessel
Model	P2	Start/Stop			
	kW	bar		litri	
BS2F 2 MPSU 304	0.55 X2	1.8 - 2.6	1.5 - 2.3	24X2	100
BS2F 2 MPSU 305	0.75 X2	2.3 - 3.1	2 - 2.8	24X2	100
BS2F 2 MPSU 306	0.9 X2	3 - 3.9	2.7 - 3.6	24X2	100
BS2F 2 MPSU 307	0.9 X2	2.9 - 4.4	2.6 - 4.1	24X2	100
BS2F 2 MPSU 504	0.9 X2	2.7 - 3.5	2.4 - 3.2	150	200
BS2F 2 MPSU 505	1.1 X2	3.4 - 4.3	3.1 - 4	150	200
BS2F 2 MPSU 506	1.1 X2	3.6 - 5.2	3.4 - 4.9	150	200
BS2F 2 MPSU 507	1.5 X2	4.6 - 6.3	4.3 - 6	150	200

400V 3~ power supply / 400V 3~ motor

Start and stop pressure controlled by pressure switches

## BSM2F

		Pressure switch		Tank	
		1	2	membrane	Vessel
Model	P2	Start/Stop			
	kW	bar		litri	
BSM2F 2 MPSUM 304	0.55 X2	1.8 - 2.6	1.5 - 2.3	24X2	100
BSM2F 2 MPSUM 305	0.75 X2	2.3 - 3.1	2 - 2.8	24X2	100
BSM2F 2 MPSUM 306	0.9 X2	3 - 3.9	2.7 - 3.6	24X2	100
BSM2F 2 MPSUM 307	0.9 X2	2.9 - 4.4	2.6 - 4.1	24X2	100
BSM2F 2 MPSUM 504	0.9 X2	2.7 - 3.5	2.4 - 3.2	150	200
BSM2F 2 MPSUM 505	1.1 X2	3.4 - 4.3	3.1 - 4	150	200
BSM2F 2 MPSUM 506	1.1 X2	3.6 - 5.2	3.4 - 4.9	150	200
BSM2F 2 MPSUM 507	1.5 X2	4.6 - 6.3	4.3 - 6	150	200

230V 1~ power supply / 230V 1~ motor

Start and stop pressure controlled by pressure switches

## BS3F

		Transducer	Tank	
		1	membrane	Vessel
Model	P2	Start/Stop		
	kW	bar	litri	
BS3F 3 MPSU 304	0.55 X3	1.8 - 2.6	24X2	100
BS3F 3 MPSU 305	0.75 X3	2.3 - 3.1	24X2	100
BS3F 3 MPSU 306	0.9 X3	3 - 3.9	24X2	100
BS3F 3 MPSU 307	0.9 X3	2.9 - 4.4	24X2	100
BS3F 3 MPSU 504	0.9 X3	2.7 - 3.5	150	200
BS3F 3 MPSU 505	1.1 X3	3.4 - 4.3	150	200
BS3F 3 MPSU 506	1.1 X3	3.6 - 5.2	150	200
BS3F 3 MPSU 507	1.5 X3	4.6 - 6.3	150	200

400V 3~ power supply / 400V 3~ motor

Start and stop pressure controlled by a pressure transducer

## BS, MPSU



## Variable speed pump units with frequency converter

## BSM1V ...-EMT

		voltage	
		Mains Voltage	Motor
Model	P2	1 ~230 V	3 ~230 V
	kW	A	bar
BSM1V 1 MPSU 304-EMT	0.55	6,5	2,8
BSM1V 1 MPSU 305-EMT	0.75	7,7	3,3
BSM1V 1 MPSU 306-EMT	0.9	8,8	3,8
BSM1V 1 MPSU 307-EMT	0.9	10,5	4,5
BSM1V 1 MPSU 504-EMT	0.9	8,7	3,8
BSM1V 1 MPSU 505-EMT	1.1	10,9	4,5
BSM1V 1 MPSU 506-EMT	1.1	11,3	4,8
BSM1V 1 MPSU 507-EMT	1.5	14,6	6,9

## BSM2V ...-EMT

		voltage	
		Mains Voltage	Motor
Model	P2	1 ~230 V	3 ~230 V
	kW	A	bar
BSM2V 2 MPSU 304-EMT	0.55 X2	6,5 X 2	2,8 X 2
BSM2V 2 MPSU 305-EMT	0.75 X2	7,7 X 2	3,3 X 2
BSM2V 2 MPSU 306-EMT	0.9 X2	8,8 X 2	3,8 X 2
BSM2V 2 MPSU 307-EMT	0.9 X2	10,5 X 2	4,5 X 2
BSM2V 2 MPSU 504-EMT	0.9 X2	8,7 X 2	3,8 X 2
BSM2V 2 MPSU 505-EMT	1.1 X2	10,9 X 2	4,5 X 2
BSM2V 2 MPSU 506-EMT	1.1 X2	11,3 X 2	4,8 X 2
BSM2V 2 MPSU 507-EMT	1.5 X2	14,6 X 2	6,9 X 2

## BSM3V ...-EMT

		voltage	
		Mains Voltage	Motor
Model	P2	1 ~230 V	3 ~230 V
	kW	A	bar
BSM3V 3 MPSU 304-EMT	0.55 X3	6,5 X 3	2,8 X 3
BSM3V 3 MPSU 305-EMT	0.75 X3	7,7 X 3	3,3 X 3
BSM3V 3 MPSU 306-EMT	0.9 X3	8,8 X 3	3,8 X 3
BSM3V 3 MPSU 307-EMT	0.9 X3	10,5 X 3	4,5 X 3
BSM3V 3 MPSU 504-EMT	0.9 X3	8,7 X 3	3,8 X 3
BSM3V 3 MPSU 505-EMT	1.1 X3	10,9 X 3	4,5 X 3
BSM3V 3 MPSU 506-EMT	1.1 X3	11,3 X 3	4,8 X 3
BSM3V 3 MPSU 507-EMT	1.5 X3	14,6 X 3	6,9 X 3

## Dimensions and weights

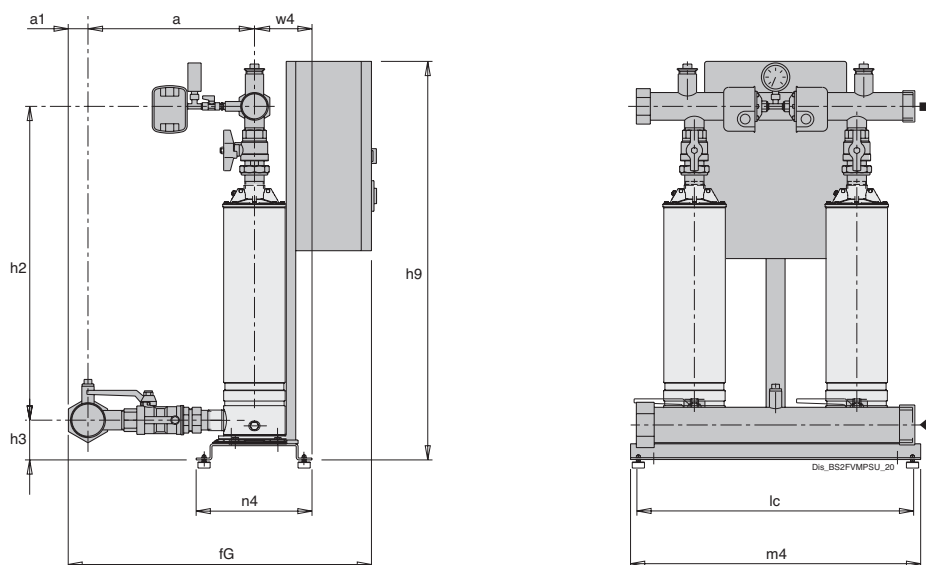

TYPE	Manifolds		mm									Kg
	DN1	DN2	a	fG	h2	h3	h9	lc	m4	n4	w4	Weight
BS2F 2 MPSU 304	G 2	G 2	330	736	629	84	865	600	625	365	220	107.5
BS2F 2 MPSU 305	G 2	G 2	330	736	698	84	865	600	625	365	220	107.5
BS2F 2 MPSU 306	G 2	G 2	330	736	722	84	865	600	625	365	220	107.5
BS2F 2 MPSU 307	G 2	G 2	330	736	746	84	865	600	625	365	220	107.5
BS2F 2 MPSU 504	G 2	G 2	330	736	674	84	865	600	625	365	220	107.5
BS2F 2 MPSU 505	G 2	G 2	330	736	698	84	865	600	625	365	220	107.5
BS2F 2 MPSU 506	G 2	G 2	330	736	767	84	865	600	625	365	220	107.5
BS2F 2 MPSU 507	G 2	G 2	330	736	816	84	865	600	625	365	220	107.5

Non-binding dimensions to be checked when ordering  
 Anti-vibration kit supplied disassembled as standard

### Dimensions and weights

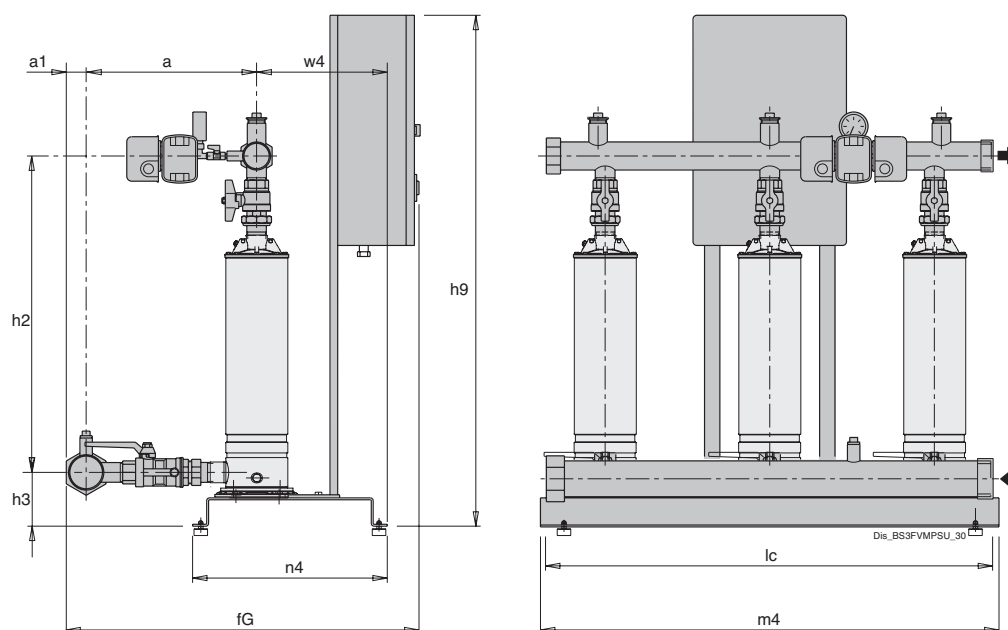

TYPE	Manifolds		mm							
	DN1	DN2	a	fG	h2	h3	h9	lc	m4	n4
BS3F 3 MPSU 304	G 2 1/2	G 2	329	735	636	105	1090	950	1000	406
BS3F 3 MPSU 305	G 2 1/2	G 2	329	735	705	105	1090	950	1000	406
BS3F 3 MPSU 306	G 2 1/2	G 2	329	735	729	105	1090	950	1000	406
BS3F 3 MPSU 307	G 2 1/2	G 2	329	735	753	105	1090	950	1000	406
BS3F 3 MPSU 504	G 2 1/2	G 2	329	735	681	105	1090	950	1000	406
BS3F 3 MPSU 505	G 2 1/2	G 2	329	735	705	105	1090	950	1000	406
BS3F 3 MPSU 506	G 2 1/2	G 2	329	735	774	105	1090	950	1000	406
BS3F 3 MPSU 507	G 2 1/2	G 2	329	735	823	105	1090	950	1000	406

Non-binding dimensions to be checked when ordering  
Anti-vibration kit supplied disassembled as standard

# BS, MPSU



## Dimensions and weights

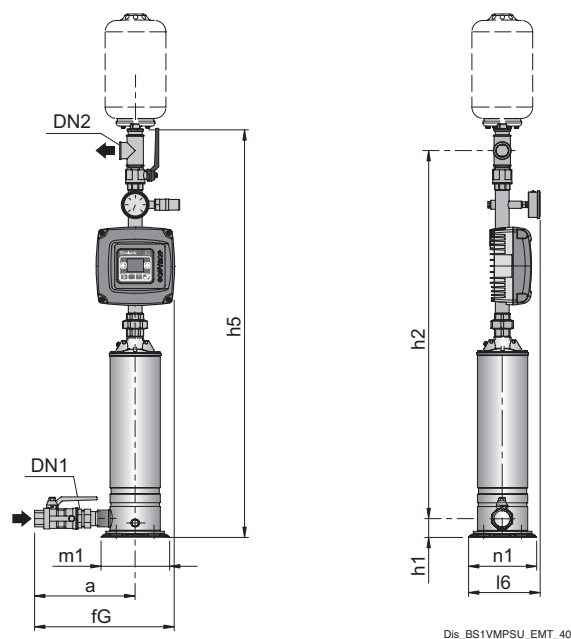

TYPE	Manifolds		mm								Kg
	DN1	DN2	a	fG	h1	h2	h5	l6	m1	n1	Weight
BSM1V 1 MPSU 304-EMT	G 1 1/4	G 1 1/4	286	376	50	952	1002	205	180	205	18.2
BSM1V 1 MPSU 305-EMT	G 1 1/4	G 1 1/4	286	376	50	1021	1071	205	180	205	18.7
BSM1V 1 MPSU 306-EMT	G 1 1/4	G 1 1/4	286	376	50	1045	1095	205	180	205	53.8
BSM1V 1 MPSU 307-EMT	G 1 1/4	G 1 1/4	286	376	50	1069	1119	205	180	205	53.8
BSM1V 1 MPSU 504-EMT	G 1 1/4	G 1 1/4	286	376	50	997	1047	205	180	205	53.8
BSM1V 1 MPSU 505-EMT	G 1 1/4	G 1 1/4	286	376	50	1021	1071	205	180	205	53.8
BSM1V 1 MPSU 506-EMT	G 1 1/4	G 1 1/4	286	376	50	1090	1140	205	180	205	53.8
BSM1V 1 MPSU 507-EMT	G 1 1/4	G 1 1/4	286	376	50	1139	1189	205	180	205	53.8

Non-binding dimensions to be checked when ordering

# BS, MPSU



## Performance, dimensions and weights

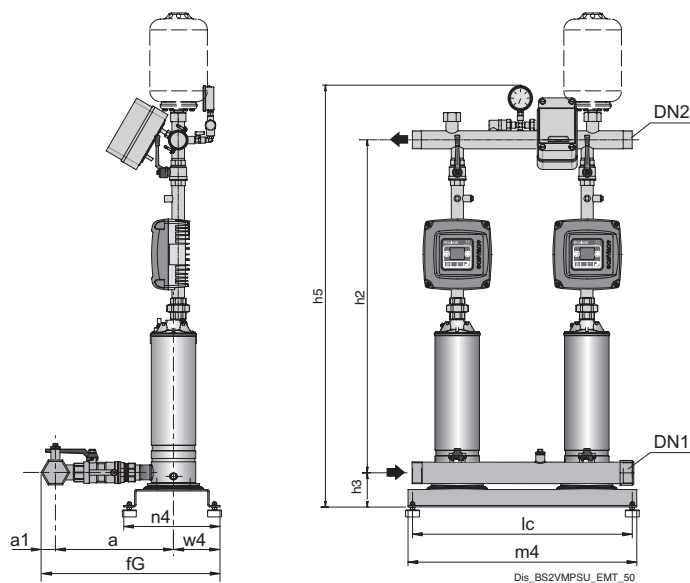

TYPE	Manifolds		mm									Kg Weight
	DN1	DN2	a	fG	h2	h3	h5	lc	m4	n4	w4	
BSM2V 2 MPSU 304-EMT	G 2	G 2	320	580	932	84	1130	600	625	365	220	107.5
BSM2V 2 MPSU 305-EMT	G 2	G 2	320	580	1001	84	1199	600	625	365	220	50
BSM2V 2 MPSU 306-EMT	G 2	G 2	320	580	1025	84	1223	600	625	365	220	107.5
BSM2V 2 MPSU 307-EMT	G 2	G 2	320	580	1049	84	1247	600	625	365	220	107.5
BSM2V 2 MPSU 504-EMT	G 2	G 2	320	580	977	84	1175	600	625	365	220	50
BSM2V 2 MPSU 505-EMT	G 2	G 2	320	580	1001	84	1199	600	625	365	220	107.5
BSM2V 2 MPSU 506-EMT	G 2	G 2	320	580	1070	84	1268	600	625	365	220	107.5
BSM2V 2 MPSU 507-EMT	G 2	G 2	320	580	1119	84	1317	600	625	365	220	60

Non-binding dimensions to be checked when ordering  
Anti-vibration kit supplied disassembled as standard

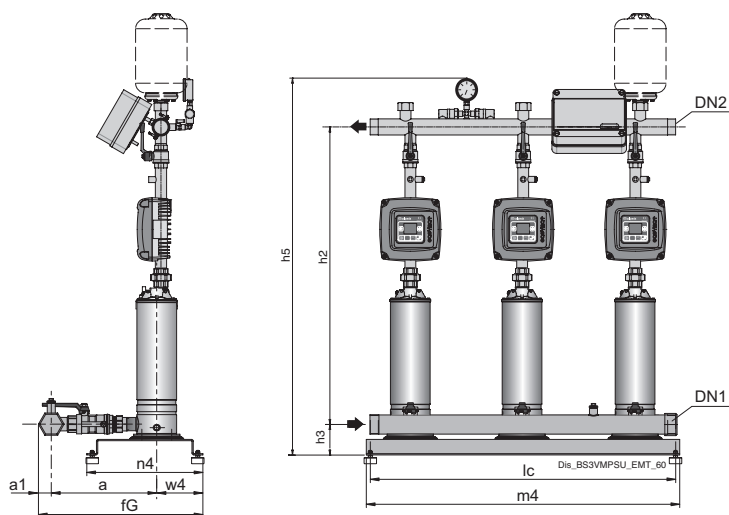

TYPE	Manifolds		mm								
	DN1	DN2	a	fG	h2	h3	h5	lc	m4	n4	w4
BSM3V 3 MPSU 304-EMT	G 2 1/2	G 2	329	566	953	105	1151	950	1000	406	237
BSM3V 3 MPSU 305-EMT	G 2 1/2	G 2	329	566	1022	105	1120	950	1000	406	237
BSM3V 3 MPSU 306-EMT	G 2 1/2	G 2	329	566	1046	105	1244	950	1000	406	237
BSM3V 3 MPSU 307-EMT	G 2 1/2	G 2	329	566	1070	105	1268	950	1000	406	237
BSM3V 3 MPSU 504-EMT	G 2 1/2	G 2	329	566	998	105	1196	950	1000	406	237
BSM3V 3 MPSU 505-EMT	G 2 1/2	G 2	329	566	1022	105	1220	950	1000	406	237
BSM3V 3 MPSU 506-EMT	G 2 1/2	G 2	329	566	1091	105	1286	950	1000	406	237
BSM3V 3 MPSU 507-EMT	G 2 1/2	G 2	329	566	1140	105	1338	950	1000	406	237

Non-binding dimensions to be checked when ordering  
Anti-vibration kit supplied disassembled as standard



# BS, MXV-B



Pressure units with 1 to 3 multi-stage vertical, fixed or variable speed pumps (INVERTER)



## Coverage chart

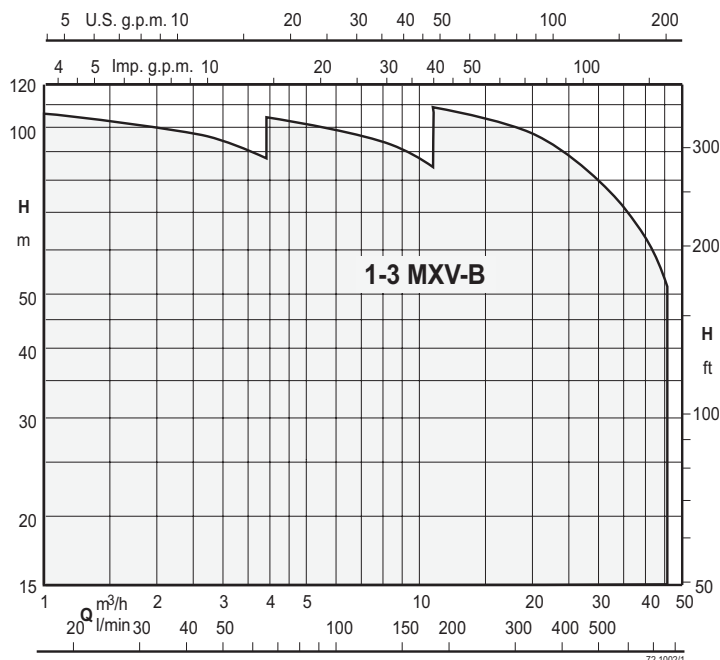

### Variable speed units with EASYMAT

BS1-3V Pressure boosting sets with 1 to 3 variable speed pumps (with EASYMAT). Depending on water consumption, one or more pumps are activated, all at variable speed, in order to guarantee the quantity of water required at the set pressure.

### Variable speed pump units with EASYMAT2

BS2V Pressure boosting sets with 2 variable speed pumps with EASYMAT2. Depending on water consumption, one or more pumps are activated, all at variable speed, in order to guarantee the quantity of water required at the set pressure.

### Variable speed pump units with WALL

BS2V Pressure boosting sets with 2 variable speed pumps with WALL. Depending on water consumption, one or more pumps are activated, all at variable speed, in order to guarantee the quantity of water required at the set pressure.

### Construction

Automatic pressure boosting plant consisting of 2 to 3 vertical multistage pumps complete with ball, non return valve on the suction side and ball valves on the delivery side. Suction and delivery manifolds for boosting sets with 2,3 pumps in stainless steel AISI 304. Connections are located on the delivery manifold for the installation of vessels G1 connection.

### Applications

To supply water in civil and industrial buildings. As pressure boosting pump to increase water pressure when needed (follow local rules).

### Motor

2-pole induction motors, 50 Hz,  $n \approx 2900$  1/min.  
 Three-phase: 230/400V  $\pm 10\%$   
 set up for inverter operation;  
 Single-phase: 230V  $\pm 10\%$  (on request)  
 Insulation class F.  
 Protection IP54  
 Constructed in accordance with IEC 60034.  
 Other voltages and frequencies on request.

### Vessels on request

When installing the unit, connect in the delivery section to a diaphragm or galvanised tank. The recommended sized are shown in the following page.

# BS, MXV-B



## Characteristic curves

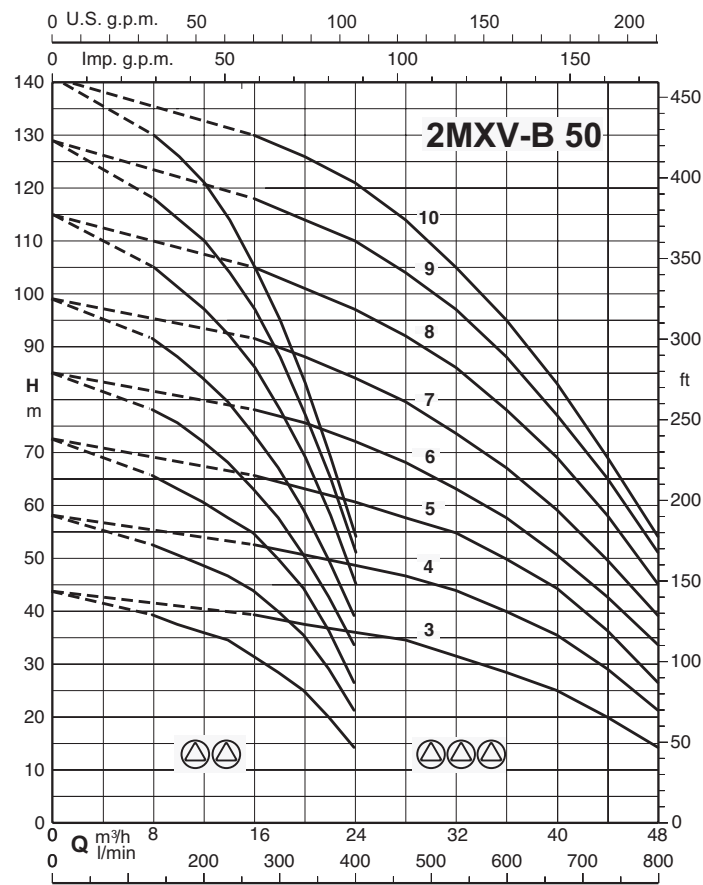
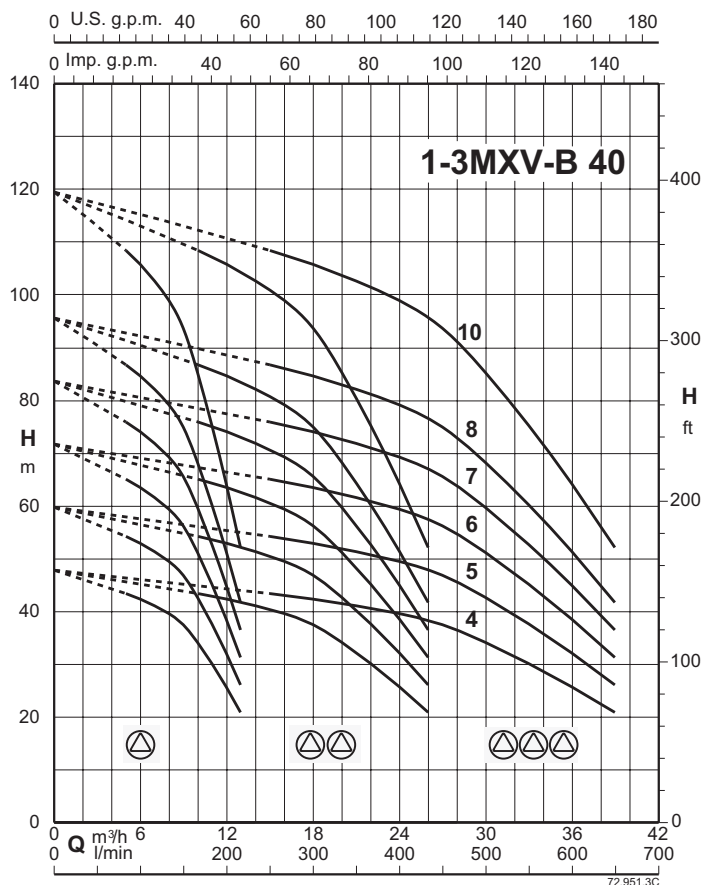
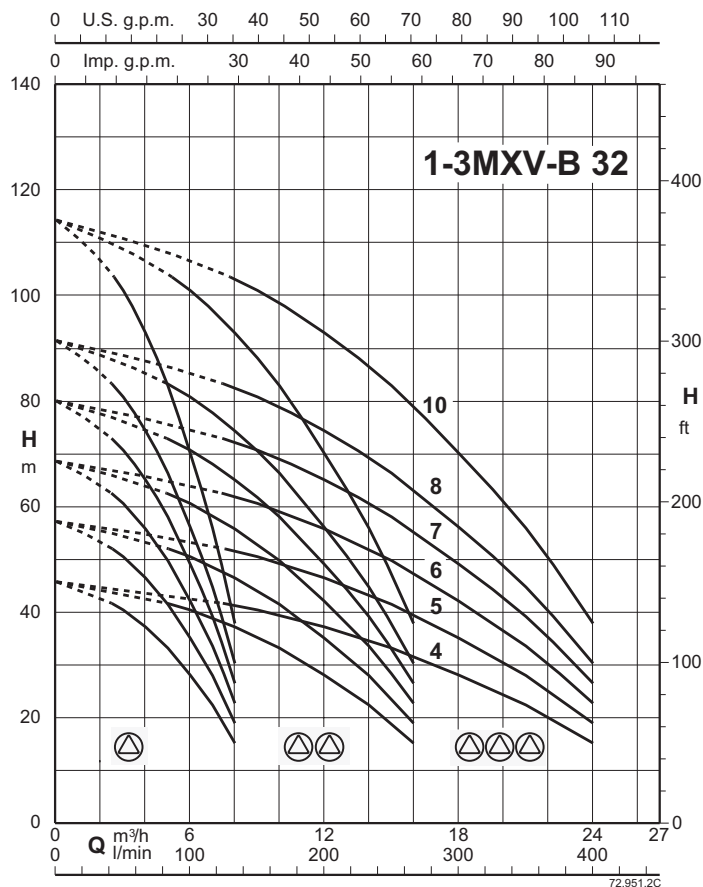
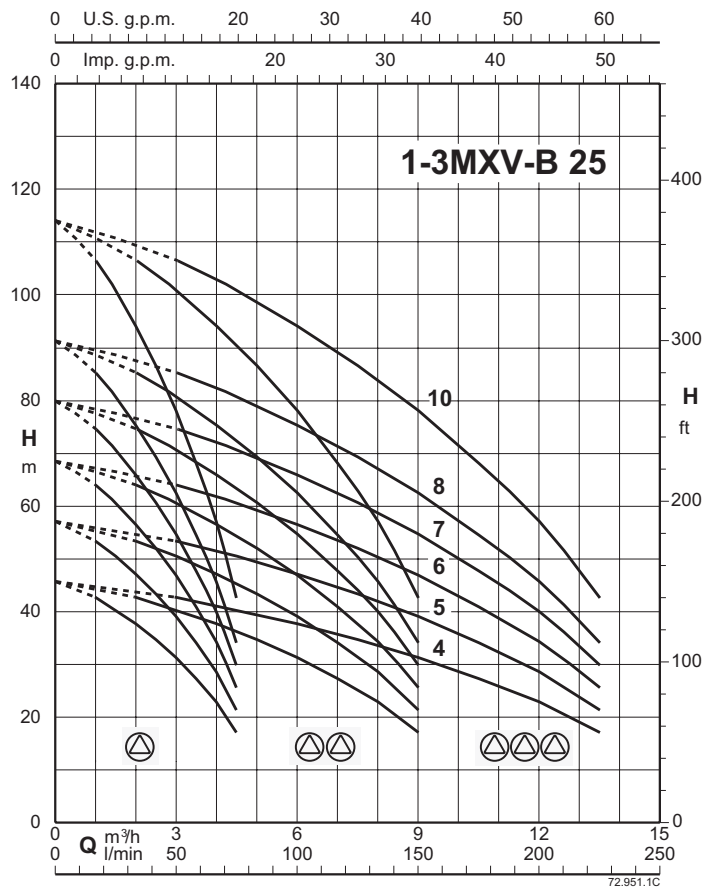

# BS, MXV-B



## Variable speed pump units with EASYMAT

### BSM1V ...-EMT

Model	P2
	kW
BSM1V 1 MXV-B 25-304 O-EMT	0.75
BSM1V 1 MXV-B 25-305 O-EMT	0.75
BSM1V 1 MXV-B 25-306 O-EMT	1.1
BSM1V 1 MXV-B 25-307 O-EMT	1.1
BSM1V 1 MXV-B 25-308 O-EMT	1.5
BSM1V 1 MXV-B 25-310 O-EMT	1.5
BSM1V 1 MXV-B 32-504 O-EMT	1.1
BSM1V 1 MXV-B 32-505 O-EMT	1.1
BSM1V 1 MXV-B 32-506 O-EMT	1.5
BSM1V 1 MXV-B 32-507 O-EMT	1.5
BSM1V 1 MXV-B 32-508 O-EMT	2.2
BSM1V 1 MXV-B 32-510 O-EMT	2.2
BSM1V 1 MXV-B 40-904 O-EMT	1.5
BSM1V 1 MXV-B 40-905 O-EMT	2.2
BSM1V 1 MXV-B 40-906 O-EMT	2.2

### BSM2V ...-EMT

Model	P2
	kW
BSM2V 2 MXV-B 25-304 O-EMT	0.75 X2
BSM2V 2 MXV-B 25-305 O-EMT	0.75 X2
BSM2V 2 MXV-B 25-306 O-EMT	1.1 X2
BSM2V 2 MXV-B 25-307 O-EMT	1.1 X2
BSM2V 2 MXV-B 25-308 O-EMT	1.5 X2
BSM2V 2 MXV-B 25-310 O-EMT	1.5 X2
BSM2V 2 MXV-B 32-504 O-EMT	1.1 X2
BSM2V 2 MXV-B 32-505 O-EMT	1.1 X2
BSM2V 2 MXV-B 32-506 O-EMT	1.5 X2
BSM2V 2 MXV-B 32-507 O-EMT	1.5 X2
BSM2V 2 MXV-B 32-508 O-EMT	2.2 X2
BSM2V 2 MXV-B 32-510 O-EMT	2.2 X2
BSM2V 2 MXV-B 40-904 O-EMT	1.5 X2
BSM2V 2 MXV-B 40-905 O-EMT	2.2 X2
BSM2V 2 MXV-B 40-906 O-EMT	2.2 X2

### BSM3V ...-EMT

Model	P2
	kW
BSM3V 3 MXV-B 25-304 O-EMT	0.75 X3
BSM3V 3 MXV-B 25-305 O-EMT	0.75 X3
BSM3V 3 MXV-B 25-306 O-EMT	1.1 X3
BSM3V 3 MXV-B 25-307 O-EMT	1.1 X3
BSM3V 3 MXV-B 25-308 O-EMT	1.5 X3
BSM3V 3 MXV-B 25-310 O-EMT	1.5 X3
BSM3V 3 MXV-B 32-504 O-EMT	1.1 X3
BSM3V 3 MXV-B 32-505 O-EMT	1.1 X3
BSM3V 3 MXV-B 32-506 O-EMT	1.5 X3
BSM3V 3 MXV-B 32-507 O-EMT	1.5 X3
BSM3V 3 MXV-B 32-508 O-EMT	2.2 X3
BSM3V 3 MXV-B 32-510 O-EMT	2.2 X3
BSM3V 3 MXV-B 40-904 O-EMT	1.5 X3
BSM3V 3 MXV-B 40-905 O-EMT	2.2 X3
BSM3V 3 MXV-B 40-906 O-EMT	2.2 X3

## Variable speed pump units with EASYMAT4

### BSM2V ...-EMT2

Model	P2
	kW
BSM2V 2 MXV-B 25-304 O-EMT2	0.75 X2
BSM2V 2 MXV-B 25-305 O-EMT2	0.75 X2
BSM2V 2 MXV-B 25-306 O-EMT2	1.1 X2
BSM2V 2 MXV-B 25-307 O-EMT2	1.1 X2
BSM2V 2 MXV-B 25-308 O-EMT2	1.5 X2
BSM2V 2 MXV-B 25-310 O-EMT2	1.5 X2
BSM2V 2 MXV-B 32-504 O-EMT2	1.1 X2
BSM2V 2 MXV-B 32-505 O-EMT2	1.1 X2
BSM2V 2 MXV-B 32-506 O-EMT2	1.5 X2
BSM2V 2 MXV-B 32-507 O-EMT2	1.5 X2
BSM2V 2 MXV-B 32-508 O-EMT2	2.2 X2
BSM2V 2 MXV-B 32-510 O-EMT2	2.2 X2
BSM2V 2 MXV-B 40-904 O-EMT2	1.5 X2
BSM2V 2 MXV-B 40-905 O-EMT2	2.2 X2
BSM2V 2 MXV-B 40-906 O-EMT2	2.2 X2

## Variable speed pump units with WALL

### BS2V ...-WALL

Model	P2
	kW
BS2V 2 MXV-B 25-304 O-WALL	0.75 X2
BS2V 2 MXV-B 25-305 O-WALL	0.75 X2
BS2V 2 MXV-B 25-306 O-WALL	1.1 X2
BS2V 2 MXV-B 25-307 O-WALL	1.1 X2
BS2V 2 MXV-B 25-308 O-WALL	1.5 X2
BS2V 2 MXV-B 25-310 O-WALL	1.5 X2
BS2V 2 MXV-B 32-504 O-WALL	1.1 X2
BS2V 2 MXV-B 32-505 O-WALL	1.1 X2
BS2V 2 MXV-B 32-506 O-WALL	1.5 X2
BS2V 2 MXV-B 32-507 O-WALL	1.5 X2
BS2V 2 MXV-B 32-508 O-WALL	2.2 X2
BS2V 2 MXV-B 32-510 O-WALL	2.2 X2
BS2V 2 MXV-B 40-904 O-WALL	1.5 X2
BS2V 2 MXV-B 40-905 O-WALL	2.2 X2
BS2V 2 MXV-B 40-906 O-WALL	2.2 X2
BS2V 2 MXV-B 40-907 O-WALL	3 X2
BS2V 2 MXV-B 40-908 O-WALL	3 X2
BS2V 2 MXV-B 40-910 O-WALL	3.7 X2
BS2V 2 MXV-B 50-1503 O-WALL	2.2 X2
BS2V 2 MXV-B 50-1504 O-WALL	3 X2
BS2V 2 MXV-B 50-1505 O-WALL	4 X2
BS2V 2 MXV-B 50-1506 O-WALL	5.5 X2
BS2V 2 MXV-B 50-1507 O-WALL	5.5 X2

## Dimensions and weights

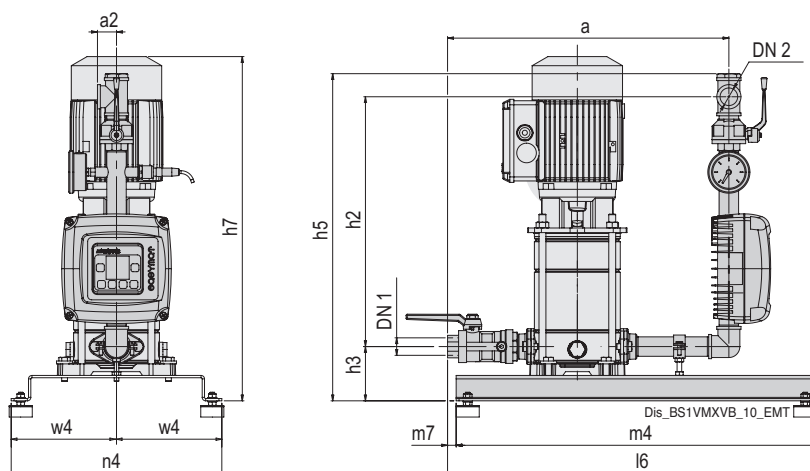

TYPE	Manifolds		mm										Kg Weight
	DN1	DN2	a	a2	h2	h3	h5	h7	l6	m4	n4	w4	
BSM1V 1 MXV-B 25-304 O-EMT	G 1	G 1	488	33	433	94	567	597	640	625	365	183	29
BSM1V 1 MXV-B 25-305 O-EMT	G 1	G 1	488	33	433	94	567	621	640	625	365	183	30.4
BSM1V 1 MXV-B 25-306 O-EMT	G 1	G 1	488	33	433	94	567	645	640	625	365	183	32.5
BSM1V 1 MXV-B 25-307 O-EMT	G 1	G 1	488	33	433	94	567	669	640	625	365	183	34
BSM1V 1 MXV-B 25-308 O-EMT	G 1	G 1	488	33	433	94	567	693	640	625	365	183	35.3
BSM1V 1 MXV-B 25-310 O-EMT	G 1	G 1	488	33	433	94	567	741	640	625	365	183	37.6
BSM1V 1 MXV-B 32-504 O-EMT	G 1 1/4	G 1 1/4	528	45	463	94	617	597	662	625	365	183	34
BSM1V 1 MXV-B 32-505 O-EMT	G 1 1/4	G 1 1/4	528	45	463	94	617	621	662	625	365	183	34.6
BSM1V 1 MXV-B 32-506 O-EMT	G 1 1/4	G 1 1/4	528	45	463	94	617	645	662	625	365	183	36
BSM1V 1 MXV-B 32-507 O-EMT	G 1 1/4	G 1 1/4	528	45	463	94	617	669	662	625	365	183	37.9
BSM1V 1 MXV-B 32-508 O-EMT	G 1 1/4	G 1 1/4	528	45	463	94	617	733	662	625	365	183	48
BSM1V 1 MXV-B 32-510 O-EMT	G 1 1/4	G 1 1/4	528	45	463	94	617	781	662	625	365	183	49.5
BSM1V 1 MXV-B 40-904 O-EMT	G 1 1/2	G 1 1/2	590	46.5	547	94	734	65	712	625	365	183	40
BSM1V 1 MXV-B 40-905 O-EMT	G 1 1/2	G 1 1/2	590	46.5	547	94	734	715	712	625	365	183	44
BSM1V 1 MXV-B 40-906 O-EMT	G 1 1/2	G 1 1/2	590	46.5	547	94	734	745	712	625	365	183	54.5

Non-binding dimensions to be checked when ordering  
 Anti-vibration kit supplied disassembled as standard

## Dimensions and weights

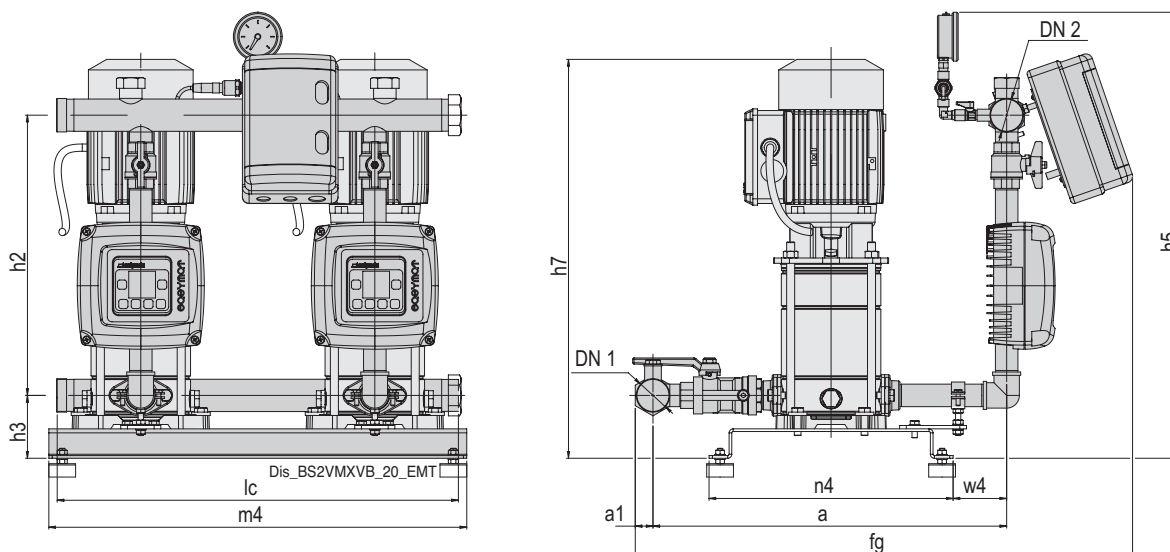

TYPE	Manifolds		mm											Kg Weight
	DN1	DN2	a	a1	fG	h2	h3	h5	h7	lc	m4	n4	w4	
BSM2V 2 MXV-B 25-304 O-EMT	G 1 1/2	G 1 1/2	529	26.5	744	420	94	667	597	600	625	365	80	70.4
BSM2V 2 MXV-B 25-305 O-EMT	G 1 1/2	G 1 1/2	529	26.5	744	420	94	667	621	600	625	365	80	71.3
BSM2V 2 MXV-B 25-306 O-EMT	G 1 1/2	G 1 1/2	529	26.5	744	420	94	667	645	600	625	365	80	81
BSM2V 2 MXV-B 25-307 O-EMT	G 1 1/2	G 1 1/2	529	26.5	744	420	94	667	669	600	625	365	80	81.6
BSM2V 2 MXV-B 25-308 O-EMT	G 1 1/2	G 1 1/2	529	26.5	744	420	94	667	693	600	625	365	80	82.4
BSM2V 2 MXV-B 25-310 O-EMT	G 1 1/2	G 1 1/2	529	26.5	744	420	94	667	741	600	625	365	80	85.4
BSM2V 2 MXV-B 32-504 O-EMT	G 2	G 2	571	32	795	443	94	690	597	600	625	365	97	80.6
BSM2V 2 MXV-B 32-505 O-EMT	G 2	G 2	571	32	795	443	94	690	621	600	625	365	97	78.9
BSM2V 2 MXV-B 32-506 O-EMT	G 2	G 2	571	32	795	443	94	690	645	600	625	365	97	86.7
BSM2V 2 MXV-B 32-507 O-EMT	G 2	G 2	571	32	795	443	94	690	669	600	625	365	97	89.5
BSM2V 2 MXV-B 32-508 O-EMT	G 2	G 2	571	32	795	443	94	690	733	600	625	365	97	92.7
BSM2V 2 MXV-B 32-510 O-EMT	G 2	G 2	571	32	795	443	94	690	781	600	625	365	97	94.6
BSM2V 2 MXV-B 40-904 O-EMT	G 2 1/2	G 2 1/2	645	40	900	479	124	757	645	600	625	365	114	93.5
BSM2V 2 MXV-B 40-905 O-EMT	G 2 1/2	G 2 1/2	645	40	900	479	124	757	715	600	625	365	114	99.7
BSM2V 2 MXV-B 40-906 O-EMT	G 2 1/2	G 2 1/2	645	40	900	479	124	757	745	600	625	365	114	102.8

Non-binding dimensions to be checked when ordering  
 Anti-vibration kit supplied disassembled as standard

## Dimensions and weights

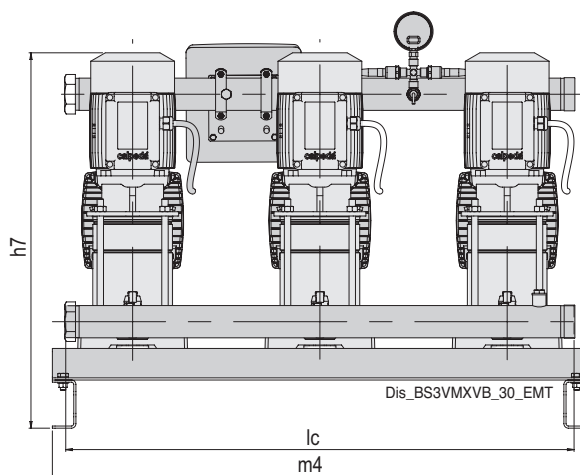
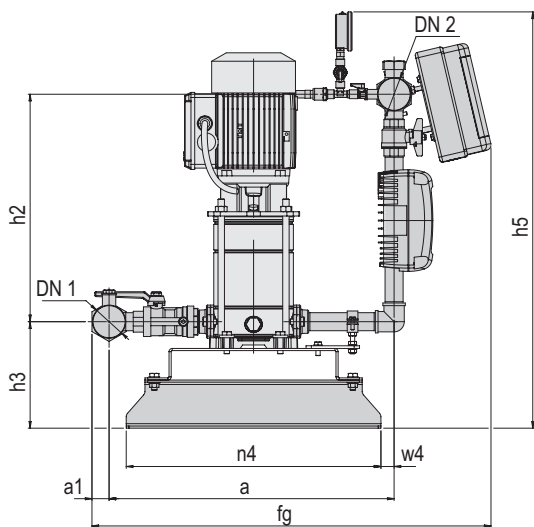

TYPE	Manifolds		mm											Kg
	DN1	DN2	a	a1	fG	h2	h3	h5	h7	lc	m4	n4	w4	Weight
BSM3V 3 MXV-B 25-304 O-EMT	G 2	G 2	533	32	746	423	199	776	702	950	1000	476	25	-
BSM3V 3 MXV-B 25-305 O-EMT	G 2	G 2	533	32	746	423	199	776	726	950	1000	476	25	116.4
BSM3V 3 MXV-B 25-306 O-EMT	G 2	G 2	533	32	746	423	199	776	750	950	1000	476	25	-
BSM3V 3 MXV-B 25-307 O-EMT	G 2	G 2	533	32	746	423	199	776	774	950	1000	476	25	-
BSM3V 3 MXV-B 25-308 O-EMT	G 2	G 2	533	32	746	423	199	776	798	950	1000	476	25	-
BSM3V 3 MXV-B 25-310 O-EMT	G 2	G 2	533	32	746	423	199	776	846	950	1000	476	25	-
BSM3V 3 MXV-B 32-504 O-EMT	G 2 1/2	G 2 1/2	579	40	814	451	199	803	702	950	1000	476	42	-
BSM3V 3 MXV-B 32-505 O-EMT	G 2 1/2	G 2 1/2	579	40	814	451	199	803	726	950	1000	476	42	-
BSM3V 3 MXV-B 32-506 O-EMT	G 2 1/2	G 2 1/2	579	40	814	451	199	803	750	950	1000	476	42	-
BSM3V 3 MXV-B 32-507 O-EMT	G 2 1/2	G 2 1/2	579	40	814	451	199	803	774	950	1000	476	42	-
BSM3V 3 MXV-B 32-508 O-EMT	G 2 1/2	G 2 1/2	579	40	814	451	199	803	838	950	1000	476	42	-
BSM3V 3 MXV-B 32-510 O-EMT	G 2 1/2	G 2 1/2	579	40	814	451	199	803	886	950	1000	476	42	153
BSM3V 3 MXV-B 40-904 O-EMT	G 3	G 3	746	48	908	485	229	868	750	950	1000	476	59	150
BSM3V 3 MXV-B 40-905 O-EMT	G 3	G 3	746	48	908	485	229	868	820	950	1000	476	59	-
BSM3V 3 MXV-B 40-906 O-EMT	G 3	G 3	746	48	908	485	229	868	850	950	1000	476	59	166

Non-binding dimensions to be checked when ordering

## Dimensions and weights

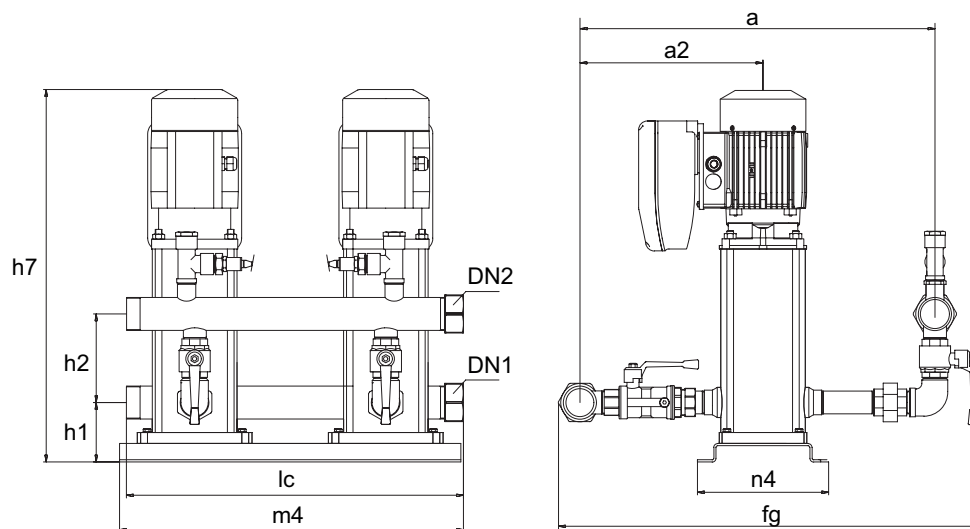

TYPE	Manifolds		mm									Kg
	DN1	DN2	a	a2	fG	h1	h2	h7	lc	m4	n4	Weight
BSM2V 2 MXV-B 25-304 O-EMT2	G 2	G 1 1/2	647	315	700	109	169	597	600	625	240	-
BSM2V 2 MXV-B 25-305 O-EMT2	G 2	G 1 1/2	647	315	700	109	169	621	600	625	240	-
BSM2V 2 MXV-B 25-306 O-EMT2	G 2	G 1 1/2	647	315	700	109	169	645	600	625	240	-
BSM2V 2 MXV-B 25-307 O-EMT2	G 2	G 1 1/2	647	315	700	109	169	669	600	625	240	-
BSM2V 2 MXV-B 25-308 O-EMT2	G 2	G 1 1/2	647	315	700	118	169	693	600	625	365	-
BSM2V 2 MXV-B 25-310 O-EMT2	G 2	G 1 1/2	647	315	700	118	169	741	600	625	365	-
BSM2V 2 MXV-B 32-504 O-EMT2	G 2	G 2	683	345	748	118	188	597	600	625	365	-
BSM2V 2 MXV-B 32-505 O-EMT2	G 2	G 2	683	345	748	118	188	621	600	625	365	-
BSM2V 2 MXV-B 32-506 O-EMT2	G 2	G 2	683	345	748	118	188	645	600	625	365	-
BSM2V 2 MXV-B 32-507 O-EMT2	G 2	G 2	683	345	748	118	188	669	600	625	365	-
BSM2V 2 MXV-B 32-508 O-EMT2	G 2	G 2	683	345	748	118	188	733	600	625	365	-
BSM2V 2 MXV-B 32-510 O-EMT2	G 2	G 2	683	345	748	118	188	781	600	625	365	-
BSM2V 2 MXV-B 40-904 O-EMT2	G 2 1/2	G 2 1/2	773	425	841	138	215	645	600	1000	365	-
BSM2V 2 MXV-B 40-905 O-EMT2	G 2 1/2	G 2 1/2	773	425	841	138	215	715	600	1000	365	-
BSM2V 2 MXV-B 40-906 O-EMT2	G 2 1/2	G 2 1/2	773	425	841	138	215	745	600	1000	365	102

Non-binding dimensions to be checked when ordering



## Dimensions and weights

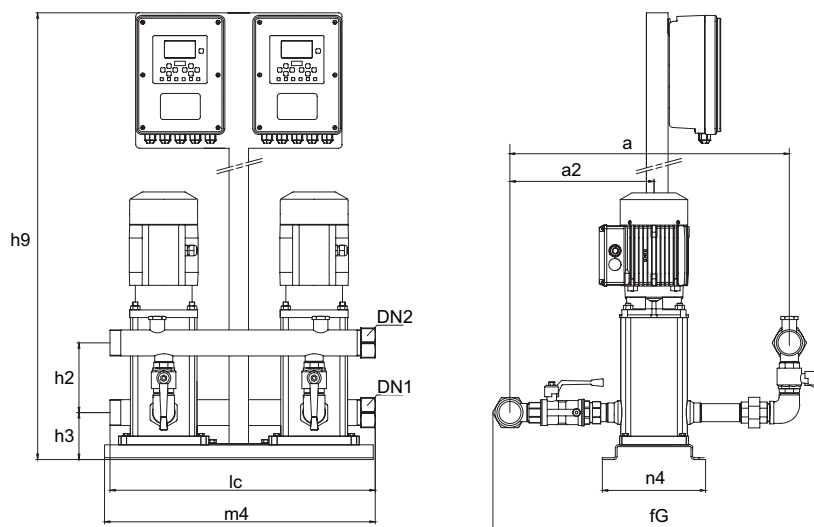

TYPE	Manifolds		mm									Kg
	DN1	DN2	a	a2	fG	h2	h3	h9	lc	m4	n4	Weight
BS2V 2 MXV-B 25-304 O-WALL	G 2	G 1 1/2	647	315	700	169	109	1384	600	625	240	-
BS2V 2 MXV-B 25-305 O-WALL	G 2	G 1 1/2	647	315	700	169	109	1384	600	625	240	-
BS2V 2 MXV-B 25-306 O-WALL	G 2	G 1 1/2	647	315	700	169	109	1384	600	625	240	-
BS2V 2 MXV-B 25-307 O-WALL	G 2	G 1 1/2	647	315	700	169	109	1384	600	625	240	-
BS2V 2 MXV-B 25-308 O-WALL	G 2	G 1 1/2	647	315	700	169	109	1384	600	625	240	-
BS2V 2 MXV-B 25-310 O-WALL	G 2	G 1 1/2	647	315	700	169	109	1384	600	625	240	-
BS2V 2 MXV-B 32-504 O-WALL	G 2	G 2	683	345	748	188	118	1393	600	625	365	-
BS2V 2 MXV-B 32-505 O-WALL	G 2	G 2	683	345	748	188	118	1393	600	625	365	-
BS2V 2 MXV-B 32-506 O-WALL	G 2	G 2	683	345	748	188	118	1393	600	625	365	-
BS2V 2 MXV-B 32-507 O-WALL	G 2	G 2	683	345	748	188	118	1393	600	625	365	100
BS2V 2 MXV-B 32-508 O-WALL	G 2	G 2	683	345	748	188	118	1393	600	625	365	122
BS2V 2 MXV-B 32-510 O-WALL	G 2	G 2	683	345	748	188	118	1393	600	625	365	-
BS2V 2 MXV-B 40-904 O-WALL	G 2 1/2	G 2 1/2	773	425	841	215	138	1393	600	1000	365	-
BS2V 2 MXV-B 40-905 O-WALL	G 2 1/2	G 2 1/2	773	425	841	215	138	1393	600	1000	365	-
BS2V 2 MXV-B 40-906 O-WALL	G 2 1/2	G 2 1/2	773	425	841	215	138	1393	600	1000	365	120
BS2V 2 MXV-B 40-907 O-WALL	G 2 1/2	G 2 1/2	773	425	841	215	138	1393	600	1000	365	-
BS2V 2 MXV-B 40-908 O-WALL	G 2 1/2	G 2 1/2	773	425	841	215	138	1393	600	1000	365	135
BS2V 2 MXV-B 40-910 O-WALL	G 2 1/2	G 2 1/2	773	425	841	215	138	1393	600	1000	365	-
BS2V 2 MXV-B 50-1503 O-WALL	G 3	G 3	793	479	888	148	148	1408	600	1000	406	-
BS2V 2 MXV-B 50-1504 O-WALL	G 3	G 3	793	479	888	148	148	1408	600	1000	406	-
BS2V 2 MXV-B 50-1505 O-WALL	G 3	G 3	793	479	888	148	148	1408	600	1000	406	-
BS2V 2 MXV-B 50-1506 O-WALL	G 3	G 3	793	479	888	148	148	1408	600	1000	406	-
BS2V 2 MXV-B 50-1507 O-WALL	G 3	G 3	793	479	888	148	148	1408	600	1000	406	-

Non-binding dimensions to be checked when ordering

Pressure units with 1 to 3 multi-stage vertical, fixed or variable speed pumps (INVERTER)



#### Fixed speed units

BS 1-6F Pressure boosting sets with 1 to 6 fixed speed pump.  
Sets with 4,5 and 6 pumps on request.  
Depending on the reduction of the pressure in the system, the pressure switches determine the starting up of the pumps in sequence and the microprocessor alternates the starts.

#### Variable speed units with I-MAT

BS2-3V Pressure boosting sets with 2 to 3 variable speed pumps (with I-MAT).  
Depending on water consumption, one or more pumps are activated, all at variable speed, in order to guarantee the quantity of water required at the set pressure.

#### Variable speed pump units with WALL

BS2V Pressure boosting sets with 2 variable speed pumps with WALL.  
Depending on water consumption, one or more pumps are activated, all at variable speed, in order to guarantee the quantity of water required at the set pressure.

#### Construction

Automatic pressure boosting plant consisting of 1 to 6 vertical multistage pumps complete with ball, non return valve on the suction side and ball valves on the delivery side.

Suction and delivery manifolds made of 1.4301 EN 10088 (AISI 304) for units with 2 and 3 pumps.

Set up for mounting cylindrical tanks with G1 connection.

Electrical control boards:

- with microprocessor control for fixed speed pumps. Motor starting is direct up to 5.5 kW and Y/Δ for powers from 7.5 to 37 kW.
- - with frequency converter for variable speed pump units.

The unit includes one pressure gauge and three adjustable differential pressure switches or pressure transducer.

#### Applications

To supply water in civil and industrial buildings.  
For increasing network pressure (follow local specifications).

#### Coverage chart

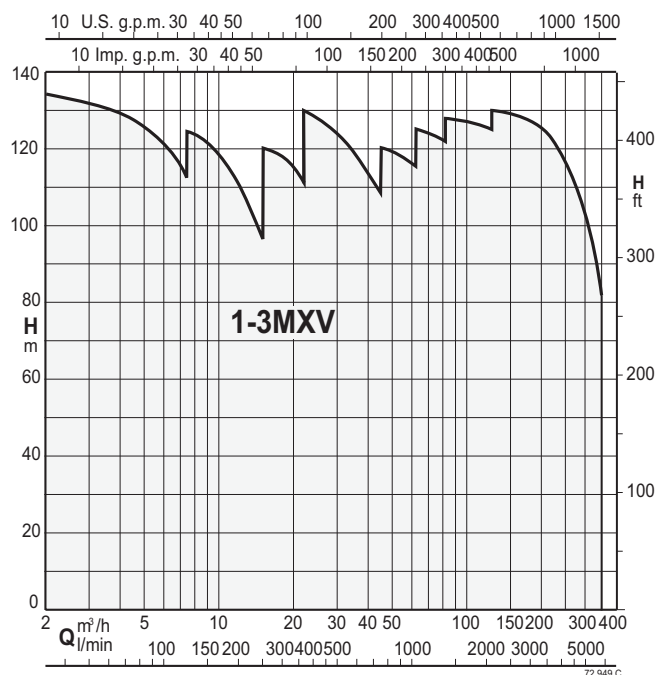

#### Motor

2-pole induction motors, 50 Hz,  $n \approx 2900$  1/min.

Three-phase

230/400V  $\pm 10\%$  up to a 3 kW  
set up for inverter operation;  
400/690V  $\pm 10\%$  for 4 kW to 37 kW,  
set up for inverter operation.

Single-phase 230 V  $\pm 10\%$ ,

Insulation class F.

IP protection: IP55

Constructed in accordance with IEC 60034.

Other voltages and frequencies on request.

#### Vessels on request

When installing the unit, connect in the delivery section to a diaphragm or galvanised tank.

The recommended sizes are shown in the following page.

#### Special features on request

Pressure unit with 4, 5 and 6 pumps

## Characteristic curves

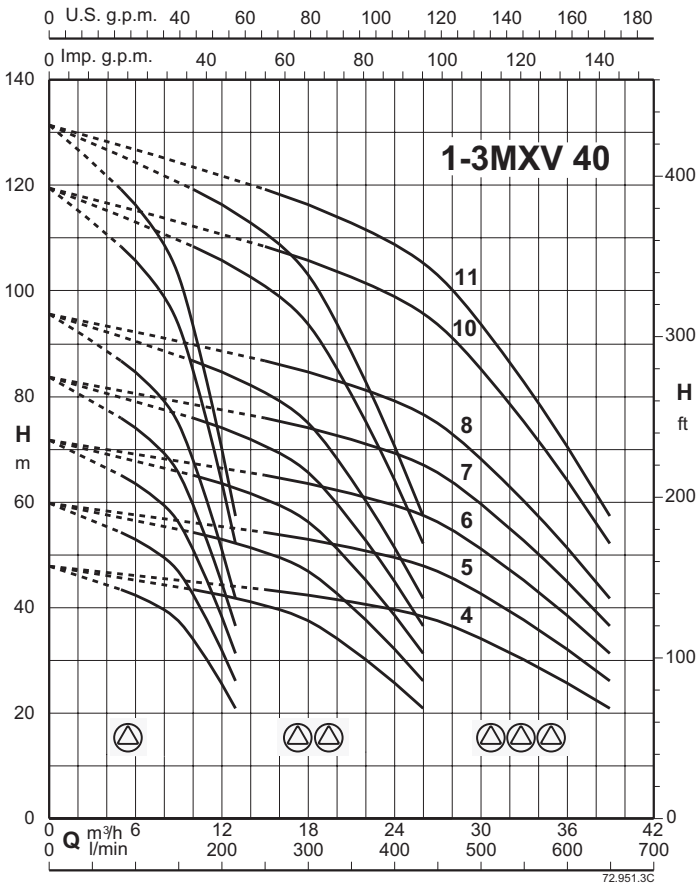
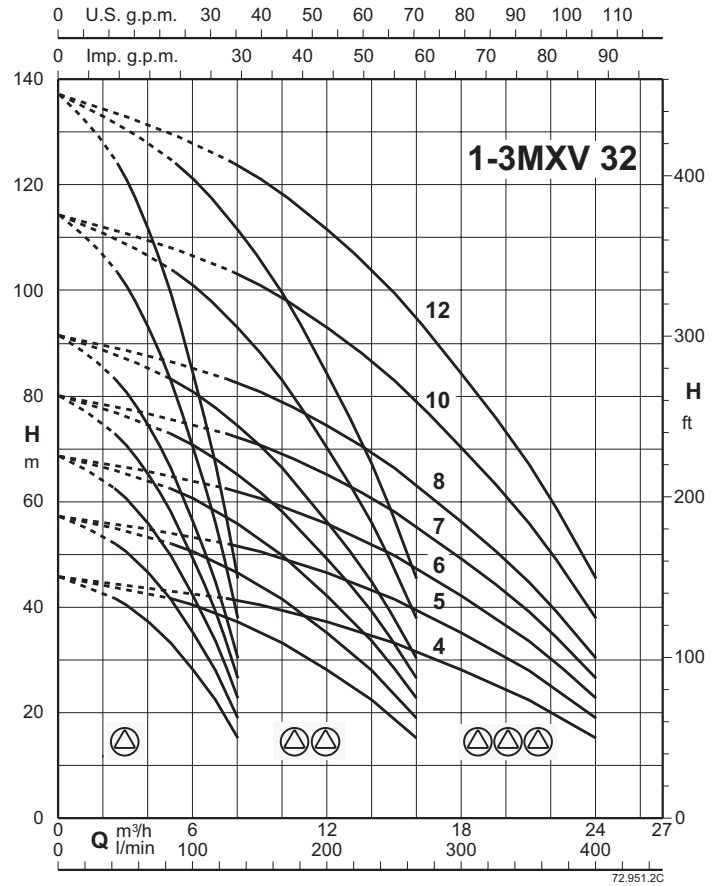
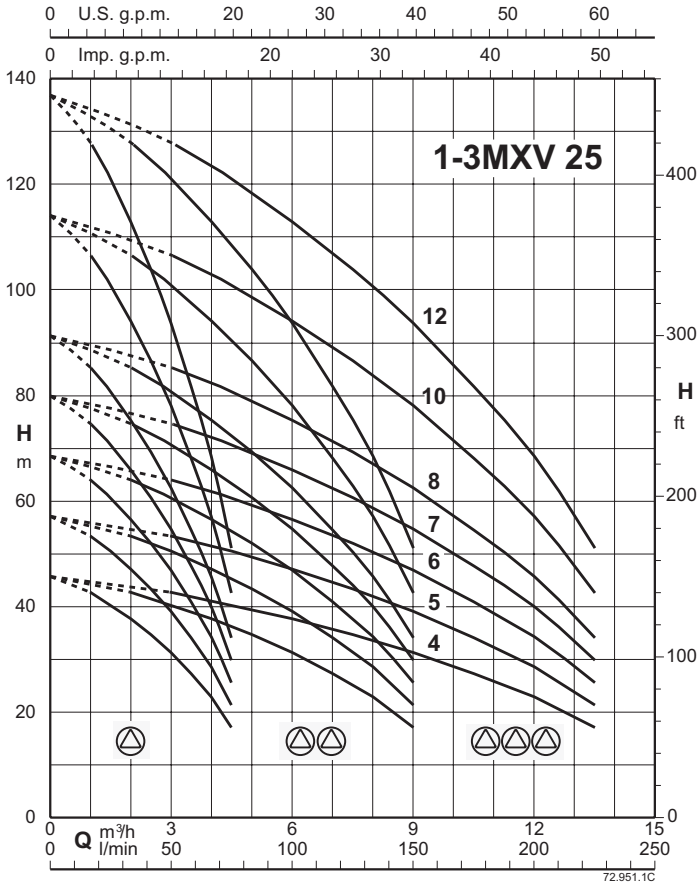

## Characteristic curves

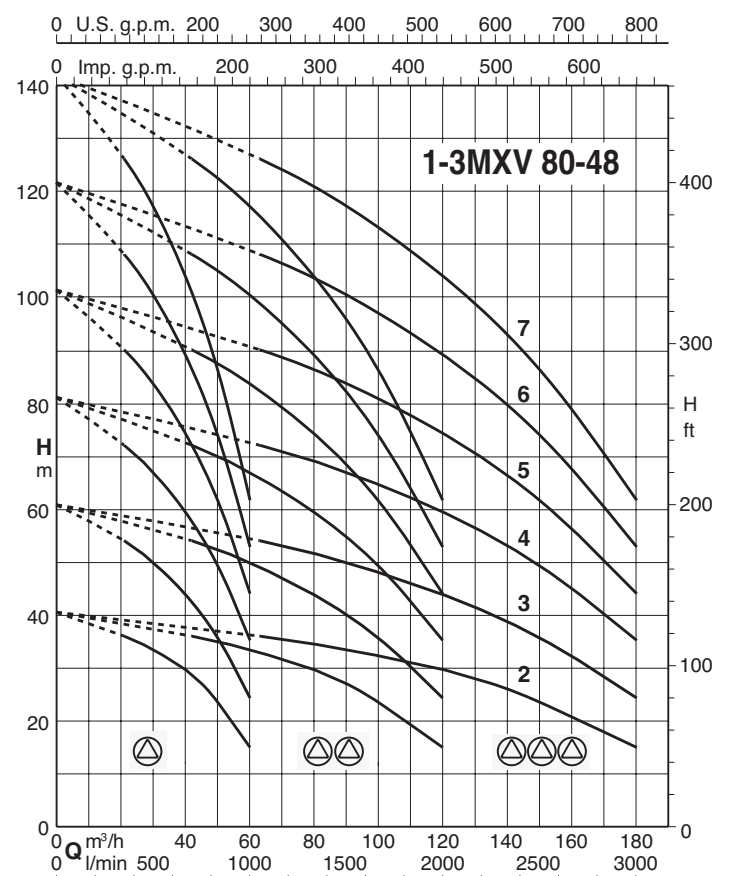
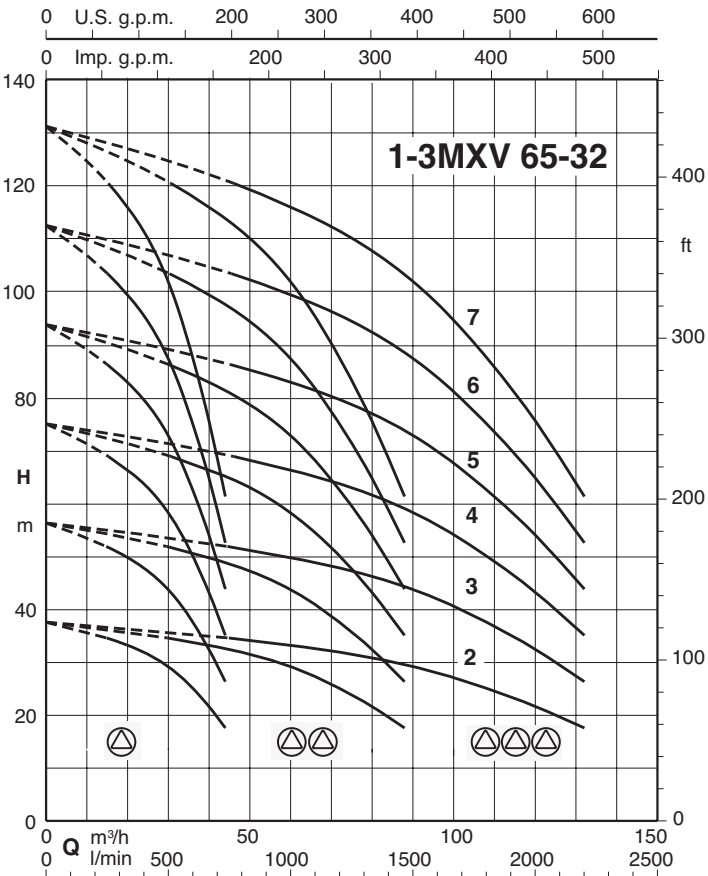
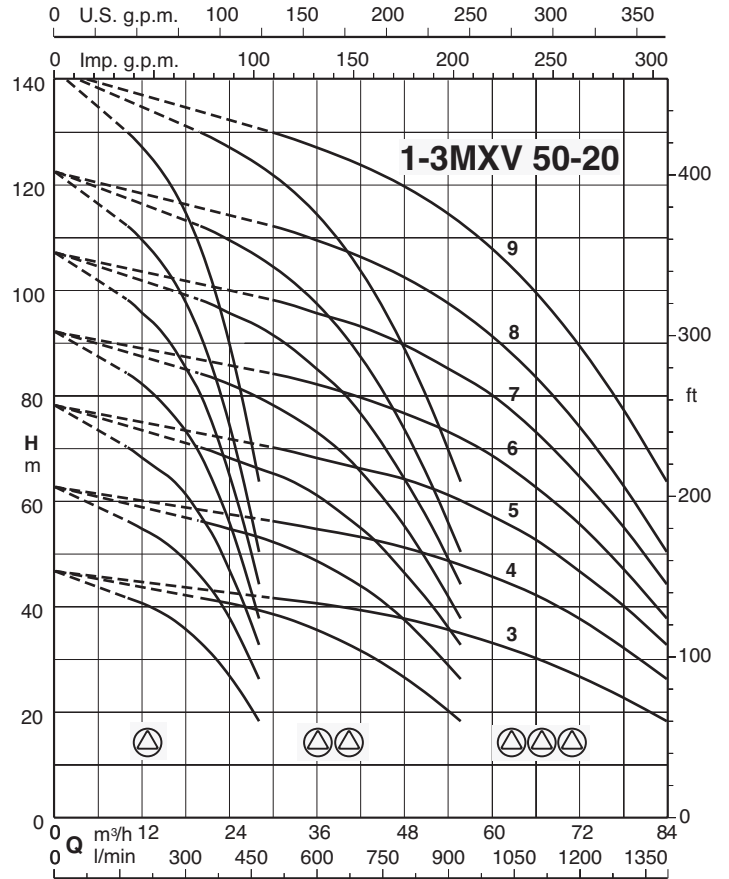
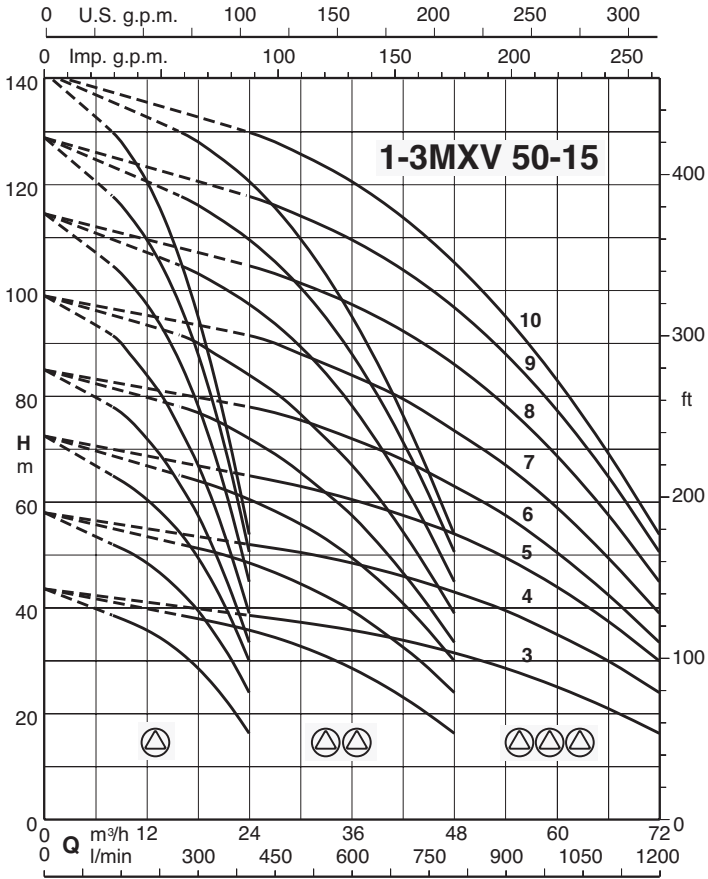

72.953.2C

72.953.3C

## Characteristic curves

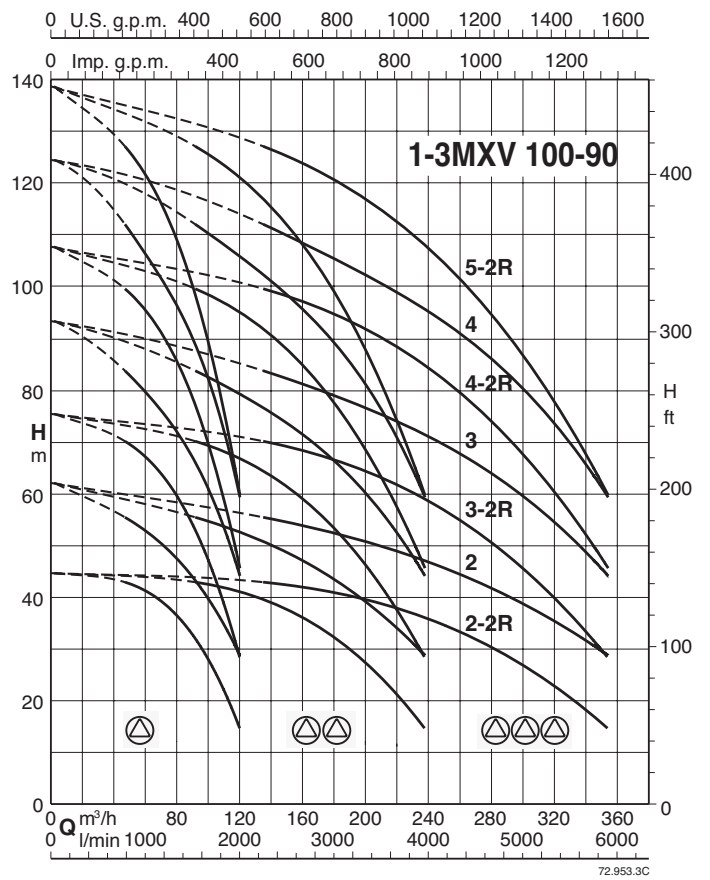
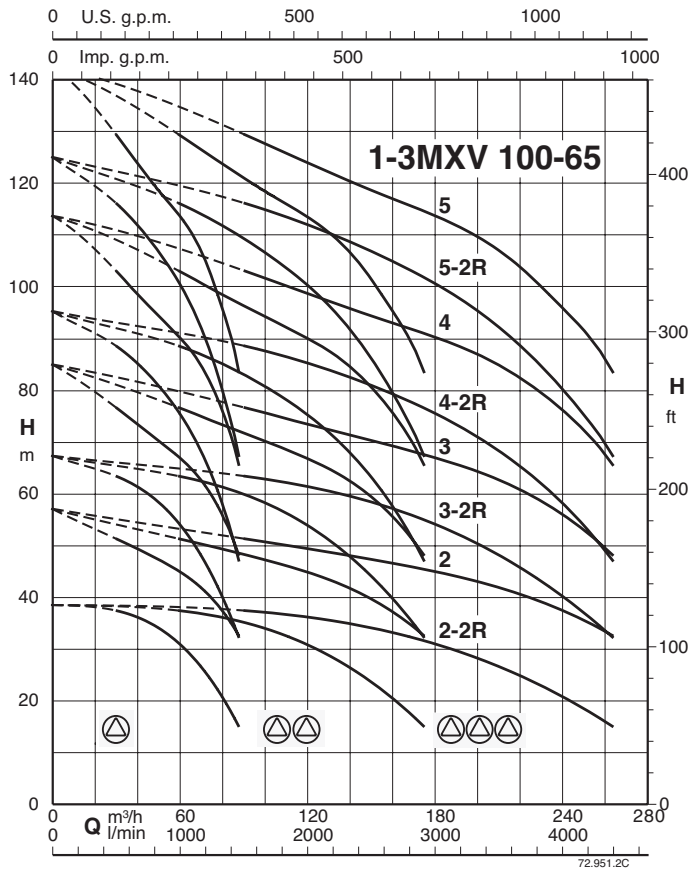

## Fixed speed pump units

## BS1F

		Pressure switch		Tank	
		1		membrane	Vessel
Model	P2	Start/Stop	litri		
	kW	bar			
BS1F 1 MXV 25-304 O	0.75	3 - 3.9	60	100	
BS1F 1 MXV 25-305 O	0.75	3.3 - 4.8	80	100	
BS1F 1 MXV 25-306 O	1.1	4.1 - 5.8	80	100	
BS1F 1 MXV 25-307 O	1.1	5 - 6.7	100	100	
BS1F 1 MXV 25-308 O	1.5	5.9 - 7.8	100	100	
BS1F 1 MXV 25-310 O	1.5	7.5 - 9.7	150	200	
BS1F 1 MXV 25-312 O	2.2	10.1 - 11.6	200	300	
BS1F 1 MXV 32-504 O	1.1	3 - 3.8	300	500	
BS1F 1 MXV 32-505 O	1.1	3.2 - 4.7	200	300	
BS1F 1 MXV 32-506 O	1.5	4 - 5.7	200	300	
BS1F 1 MXV 32-507 O	1.5	4.9 - 6.6	300	500	
BS1F 1 MXV 32-508 O	2.2	5.7 - 7.6	300	500	
BS1F 1 MXV 32-510 O	2.2	7.4 - 9.5	200	300	
BS1F 1 MXV 32-512 O	3	9.8 - 11.3	300	500	
BS1F 1 MXV 40-904 O	1.5	3 - 3.9	500	800	
BS1F 1 MXV 40-905 O	2.2	3.4 - 4.9	500	800	
BS1F 1 MXV 40-906 O	2.2	4.3 - 5.9	500	800	
BS1F 1 MXV 40-907 O	3	5.1 - 6.9	750	1000	
BS1F 1 MXV 40-908 O	3	6 - 7.9	500	800	
BS1F 1 MXV 40-910 O	4	7.8 - 9.9	500	1000	
BS1F 1 MXV 40-911 O	4	9.4 - 10.9	1000	1500	
BS1F 1 MXV 50-1503/A	2.2	2.7 - 3.5	750	1500	
BS1F 1 MXV 50-1504	3	3.2 - 4.7	750	1500	
BS1F 1 MXV 50-1505	4	4.3 - 5.9	750	1500	
BS1F 1 MXV 50-1506	5.5	5.3 - 7.1	750	1500	
BS1F 1 MXV 50-1507	5.5	6.4 - 8.3	750	1500	
BS1F 1 MXV 50-1508/A	5.5	7.5 - 9.6	750	1500	
BS1F 1 MXV 50-1509	7.5	9.3 - 10.8	750	1500	
BS1F 1 MXV 50-1510	7.5	10.4 - 11.9	750	1500	
BS1F 1 MXV 50-2003	3	3 - 3.8	750	1500	
BS1F 1 MXV 50-2004	4	3.5 - 5.1	750	1500	
BS1F 1 MXV 50-2005	5.5	4.7 - 6.4	750	1500	
BS1F 1 MXV 50-2006	7.5	5.8 - 7.7	750	1500	
BS1F 1 MXV 50-2007	7.5	6.9 - 8.9	750	1500	
BS1F 1 MXV 50-2008	9.2	8.7 - 10.2	750	1500	
BS1F 1 MXV 50-2009	9.2	10.4 - 11.9	750	1500	
BS1F 1 MXV 65-3202/D	4	2.3 - 3.1	2000	4000	
BS1F 1 MXV 65-3203/C	5.5	3.1 - 4.7	2000	3000	
BS1F 1 MXV 65-3204/C	7.5	4.6 - 6.3	2000	4000	
BS1F 1 MXV 65-3205/D	11	5.9 - 7.8	3000	4000	
BS1F 1 MXV 65-3206/D	11	7.3 - 9.4	3000	5000	
BS1F 1 MXV 65-3207/D	15	9.5 - 11	-	6000	
BS1F 1 MXV 80-4802/C	5.5	2.5 - 3.3	3000	6000	
BS1F 1 MXV 80-4803/C	7.5	3.4 - 4.9	2000	4000	
BS1F 1 MXV 80-4804/D	11	4.8 - 6.6	3000	5000	
BS1F 1 MXV 80-4805/D	15	6.3 - 8.2	-	6000	
BS1F 1 MXV 80-4806/D	15	7.7 - 9.8	-	6000	
BS1F 1 MXV 80-4807/E	18.5	10 - 11.5	-	9000	

400V 3~ power supply / 400V 3~ motor

Start and stop pressure controlled by pressure switches

## BSM1F

		Pressure switch		Tank	
		1		membrane	Vessel
Model	P2	Start/Stop	litri		
	kW	bar			
BSM1F 1 MXVM 25-304 O	0.75	3 - 3.9	60	100	
BSM1F 1 MXVM 25-305 O	0.75	3.3 - 4.8	80	100	
BSM1F 1 MXVM 25-306 O	1.1	4.1 - 5.8	80	100	
BSM1F 1 MXVM 25-307 O	1.1	5 - 6.7	100	100	
BSM1F 1 MXVM 25-308 O	1.5	5.9 - 7.8	100	100	
BSM1F 1 MXVM 32-504 O	1.1	3 - 3.8	300	500	
BSM1F 1 MXVM 32-505 O	1.1	3.2 - 4.7	200	300	
BSM1F 1 MXVM 32-506 O	1.5	4 - 5.7	200	300	
BSM1F 1 MXVM 32-507 O	1.5	4.9 - 6.6	300	500	
BSM1F 1 MXVM 40-904 O	1.5	3 - 3.9	500	800	

230V 1~ power supply / 230V 1~ motor

Start and stop pressure controlled by a pressure transducer



## Fixed speed pump units

### BS2F

Model	P2 kW	Pressure switch		Tank	
		1	2	membrane	Vessel
		Start/Stop bar		litri	
BS2F 2 MXV 25-304 O	0.75 X2	3 - 3.9	2.7 - 3.6	60	100
BS2F 2 MXV 25-305 O	0.75 X2	3.3 - 4.8	3 - 4.5	80	100
BS2F 2 MXV 25-306 O	1.1 X2	4.1 - 5.8	3.9 - 5.5	80	100
BS2F 2 MXV 25-307 O	1.1 X2	5 - 6.7	4.7 - 6.4	100	100
BS2F 2 MXV 25-308 O	1.5 X2	5.9 - 7.8	5.6 - 7.5	100	100
BS2F 2 MXV 25-310 O	1.5 X2	7.5 - 9.7	7.3 - 9.4	150	200
BS2F 2 MXV 25-312 O	2.2 X2	10.1 - 11.6	9.8 - 11.3	200	300
BS2F 2 MXV 32-504 O	1.1 X2	3 - 3.8	2.7 - 3.5	300	500
BS2F 2 MXV 32-505 O	1.1 X2	3.2 - 4.7	2.9 - 4.4	200	300
BS2F 2 MXV 32-506 O	1.5 X2	4 - 5.7	3.7 - 5.4	200	300
BS2F 2 MXV 32-507 O	1.5 X2	4.9 - 6.6	4.6 - 6.3	300	500
BS2F 2 MXV 32-508 O	2.2 X2	5.7 - 7.6	5.4 - 7.3	300	500
BS2F 2 MXV 32-510 O	2.2 X2	7.4 - 9.5	7.1 - 9.2	200	300
BS2F 2 MXV 32-512 O	3 X2	9.8 - 11.3	9.5 - 11	300	500
BS2F 2 MXV 40-904 O	1.5 X2	3 - 3.9	2.7 - 3.6	500	800
BS2F 2 MXV 40-905 O	2.2 X2	3.4 - 4.9	3.1 - 4.6	500	800
BS2F 2 MXV 40-906 O	2.2 X2	4.3 - 5.9	4 - 5.6	500	800
BS2F 2 MXV 40-907 O	3 X2	5.1 - 6.9	4.9 - 6.6	750	1000
BS2F 2 MXV 40-908 O	3 X2	6 - 7.9	5.7 - 7.6	500	800
BS2F 2 MXV 40-910 O	4 X2	7.8 - 9.9	7.5 - 9.6	500	1000
BS2F 2 MXV 40-911 O	4 X2	9.4 - 10.9	9.1 - 10.6	1000	1500
BS2F 2 MXV 50-1503/A	2.2 X2	2.7 - 3.5	2.4 - 3.2	750	1500
BS2F 2 MXV 50-1504	3 X2	3.2 - 4.7	2.9 - 4.4	750	1500
BS2F 2 MXV 50-1505	4 X2	4.3 - 5.9	4 - 5.6	750	1500
BS2F 2 MXV 50-1506	5.5 X2	5.3 - 7.1	5 - 6.8	750	1500
BS2F 2 MXV 50-1507	5.5 X2	6.4 - 8.3	6.1 - 8	750	1500
BS2F 2 MXV 50-1508/A	5.5 X2	7.5 - 9.6	7.2 - 9.3	750	1500
BS2F 2 MXV 50-1509	7.5 X2	9.3 - 10.8	9 - 10.5	750	1500
BS2F 2 MXV 50-1510	7.5 X2	10.4 - 11.9	10.1 - 11.6	750	1500
BS2F 2 MXV 50-2003	3 X2	3 - 3.8	2.7 - 3.5	750	1500
BS2F 2 MXV 50-2004	4 X2	3.5 - 5.1	3.3 - 4.8	750	1500
BS2F 2 MXV 50-2005	5.5 X2	4.7 - 6.4	4.4 - 6.1	750	1500
BS2F 2 MXV 50-2006	7.5 X2	5.8 - 7.7	5.5 - 7.4	750	1500
BS2F 2 MXV 50-2007	7.5 X2	6.9 - 8.9	6.6 - 8.6	750	1500
BS2F 2 MXV 50-2008	9.2 X2	8.7 - 10.2	8.4 - 9.9	750	1500
BS2F 2 MXV 50-2009	9.2 X2	10.4 - 11.9	10.1 - 11.6	750	1500
BS2F 2 MXV 65-3202/D	4 X2	2.3 - 3.1	2 - 2.8	2000	4000
BS2F 2 MXV 65-3203/C	5.5 X2	3.2 - 4.7	2.9 - 4.4	2000	3000
BS2F 2 MXV 65-3204/C	7.5 X2	4.6 - 6.3	4.3 - 6	2000	4000
BS2F 2 MXV 65-3205/D	11 X2	5.9 - 7.8	5.7 - 7.5	3000	4000
BS2F 2 MXV 65-3206/D	11 X2	7.3 - 9.4	7 - 9.1	3000	5000
BS2F 2 MXV 65-3207/D	15 X2	9.5 - 11	9.2 - 10.7	-	6000
BS2F 2 MXV 80-4802/C	5.5 X2	2.5 - 3.3	2.2 - 3	3000	6000
BS2F 2 MXV 80-4803/C	7.5 X2	3.4 - 4.9	3.1 - 4.6	2000	4000
BS2F 2 MXV 80-4804/D	11 X2	4.8 - 6.6	4.5 - 6.3	3000	5000
BS2F 2 MXV 80-4805/D	15 X2	6.3 - 8.2	6 - 7.9	-	6000
BS2F 2 MXV 80-4806/D	15 X2	7.7 - 9.8	7.4 - 9.5	-	6000
BS2F 2 MXV 80-4807/E	18.5 X2	10 - 11.5	9.7 - 11.2	-	9000
BS2F 2 MXV 100-6502-2R/A	7.5 X2	2.6 - 3.4	2.3 - 3.1	-	-
BS2F 2 MXV 100-6502/A	11 X2	3.2 - 4.7	2.9 - 4.4	-	-
BS2F 2 MXV 100-6503-2R/A	15 X2	4.1 - 5.8	3.9 - 5.5	-	-
BS2F 2 MXV 100-6503/B	18.5 X2	5.1 - 6.9	4.9 - 6.6	-	-
BS2F 2 MXV 100-6504-2R/B	18.5 X2	6.1 - 8.1	5.9 - 7.8	-	-
BS2F 2 MXV 100-6504/A	22 X2	7.2 - 9.3	6.9 - 9	-	-
BS2F 2 MXV 100-6505-2R/A	30 X2	9.1 - 10.6	8.8 - 10.3	-	-
BS2F 2 MXV 100-6505/A	30 X2	10.3 - 11.8	10 - 11.5	-	-
BS2F 2 MXV 100-9002-2R/A	11 X2	3 - 3.9	2.7 - 3.6	-	-
BS2F 2 MXV 100-9002/A	15 X2	3.5 - 5.1	3.2 - 4.8	-	-
BS2F 2 MXV 100-9003-2R/B	18.5 X2	4.7 - 6.4	4.4 - 6.1	-	-
BS2F 2 MXV 100-9003/A	22 X2	5.8 - 7.7	5.5 - 7.4	-	-
BS2F 2 MXV 100-9004-2R/A	30 X2	7.1 - 9.1	6.8 - 8.8	-	-
BS2F 2 MXV 100-9004/A	30 X2	8.7 - 10.2	8.4 - 9.9	-	-
BS2F 2 MXV 100-9005-2R/A	37 X2	10.1 - 11.6	9.8 - 11.3	-	-

400V 3~ power supply / 400V 3~ motor

Start and stop pressure controlled by pressure switches

### BS3F

Model	P2 kW	Start/Stop bar	Tank	
			membrane	Vessel
			litri	
BS3F 3 MXV 25-304 O	0.75 X3	3 - 3.9	60	100
BS3F 3 MXV 25-305 O	0.75 X3	3.3 - 4.8	80	100
BS3F 3 MXV 25-306 O	1.1 X3	4.1 - 5.8	80	100
BS3F 3 MXV 25-307 O	1.1 X3	5 - 6.7	100	100
BS3F 3 MXV 25-308 O	1.5 X3	5.9 - 7.8	100	100
BS3F 3 MXV 25-310 O	1.5 X3	7.5 - 9.7	150	200
BS3F 3 MXV 25-312 O	2.2 X3	10.1 - 11.6	200	300
BS3F 3 MXV 32-504 O	1.1 X3	3 - 3.8	300	500
BS3F 3 MXV 32-505 O	1.1 X3	3.2 - 4.7	200	300
BS3F 3 MXV 32-506 O	1.5 X3	4 - 5.7	200	300
BS3F 3 MXV 32-507 O	1.5 X3	4.9 - 6.6	300	500
BS3F 3 MXV 32-508 O	2.2 X3	5.7 - 7.6	300	500
BS3F 3 MXV 32-510 O	2.2 X3	7.4 - 9.5	200	300
BS3F 3 MXV 32-512 O	3 X3	9.8 - 11.3	300	500
BS3F 3 MXV 40-904 O	1.5 X3	3 - 3.9	500	800
BS3F 3 MXV 40-905 O	2.2 X3	3.4 - 4.9	500	800
BS3F 3 MXV 40-906 O	2.2 X3	4.3 - 5.9	500	800
BS3F 3 MXV 40-907 O	3 X3	5.1 - 6.9	750	1000
BS3F 3 MXV 40-908 O	3 X3	6 - 7.9	500	800
BS3F 3 MXV 40-910 O	4 X3	7.8 - 9.9	500	1000
BS3F 3 MXV 40-911 O	4 X3	9.4 - 10.9	1000	1500
BS3F 3 MXV 50-1503/A	2.2 X3	2.7 - 3.5	750	1500
BS3F 3 MXV 50-1504	3 X3	3.2 - 4.7	750	1500
BS3F 3 MXV 50-1505	4 X3	4.3 - 5.9	750	1500
BS3F 3 MXV 50-1506	5.5 X3	5.3 - 7.1	750	1500
BS3F 3 MXV 50-1507	5.5 X3	6.4 - 8.3	750	1500
BS3F 3 MXV 50-1508/A	5.5 X3	7.5 - 9.6	750	1500
BS3F 3 MXV 50-1509	7.5 X3	9.3 - 10.8	750	1500
BS3F 3 MXV 50-1510	7.5 X3	10.4 - 11.9	750	1500
BS3F 3 MXV 50-2003	3 X3	3 - 3.8	750	1500
BS3F 3 MXV 50-2004	4 X3	3.5 - 5.1	750	1500
BS3F 3 MXV 50-2005	5.5 X3	4.7 - 6.4	750	1500
BS3F 3 MXV 50-2006	7.5 X3	5.8 - 7.7	750	1500
BS3F 3 MXV 50-2007	7.5 X3	6.9 - 8.9	750	1500
BS3F 3 MXV 50-2008	9.2 X3	8.7 - 10.2	750	1500
BS3F 3 MXV 50-2009	9.2 X3	10.4 - 11.9	750	1500
BS3F 3 MXV 65-3202/D	4 X3	2.3 - 3.1	2000	4000
BS3F 3 MXV 65-3203/C	5.5 X3	3.2 - 4.7	2000	3000
BS3F 3 MXV 65-3204/C	7.5 X3	4.6 - 6.3	2000	4000
BS3F 3 MXV 65-3205/D	11 X3	5.9 - 7.8	3000	4000
BS3F 3 MXV 65-3206/D	11 X3	7.3 - 9.4	3000	5000
BS3F 3 MXV 65-3207/D	15 X3	9.5 - 11	-	6000
BS3F 3 MXV 80-4802/C	5.5 X3	2.5 - 3.3	3000	6000
BS3F 3 MXV 80-4803/C	7.5 X3	3.4 - 4.9	2000	4000
BS3F 3 MXV 80-4804/D	11 X3	4.8 - 6.6	3000	5000
BS3F 3 MXV 80-4805/D	15 X3	6.3 - 8.2	-	6000
BS3F 3 MXV 80-4806/D	15 X3	7.7 - 9.8	-	6000
BS3F 3 MXV 80-4807/E	18.5 X3	10 - 11.5	-	9000
BS3F 3 MXV 100-6502-2R/A	7.5 X3	2.6 - 3.4	-	-
BS3F 3 MXV 100-6502/A	11 X3	3.2 - 4.7	-	-
BS3F 3 MXV 100-6503-2R/A	15 X3	4.1 - 5.8	-	-
BS3F 3 MXV 100-6503/B	18.5 X3	5.1 - 6.9	-	-
BS3F 3 MXV 100-6504-2R/B	18.5 X3	6.1 - 8.1	-	-
BS3F 3 MXV 100-6504/A	22 X3	7.2 - 9.3	-	-
BS3F 3 MXV 100-6505-2R/A	30 X3	9.1 - 10.6	-	-
BS3F 3 MXV 100-6505/A	30 X3	10.3 - 11.8	-	-
BS3F 3 MXV 100-9002-2R/A	11 X3	3 - 3.9	-	-
BS3F 3 MXV 100-9002/A	15 X3	3.6 - 5.1	-	-
BS3F 3 MXV 100-9003-2R/B	18.5 X3	4.7 - 6.4	-	-
BS3F 3 MXV 100-9003/A	22 X3	5.8 - 7.7	-	-
BS3F 3 MXV 100-9004-2R/A	30 X3	7.1 - 9.1	-	-
BS3F 3 MXV 100-9004/A	30 X3	8.7 - 10.2	-	-
BS3F 3 MXV 100-9005-2R/A	37 X3	10.1 - 11.6	-	-

400V 3~ power supply / 400V 3~ motor

Start and stop pressure controlled by a pressure transducer



BS, MXV



## Variable speed pump units with I-MAT

## BSM2V ...ITT

Model	P2 kW
BS2V 2 MXV 25-304 O-ITT	0.75 X2
BS2V 2 MXV 25-305 O-ITT	0.75 X2
BS2V 2 MXV 25-306 O-ITT	1.1 X2
BS2V 2 MXV 25-307 O-ITT	1.1 X2
BS2V 2 MXV 25-308 O-ITT	1.5 X2
BS2V 2 MXV 25-310 O-ITT	1.5 X2
BS2V 2 MXV 25-312 O-ITT	2.2 X2
BS2V 2 MXV 32-504 O-ITT	1.1 X2
BS2V 2 MXV 32-505 O-ITT	1.1 X2
BS2V 2 MXV 32-506 O-ITT	1.5 X2
BS2V 2 MXV 32-507 O-ITT	1.5 X2
BS2V 2 MXV 32-508 O-ITT	2.2 X2
BS2V 2 MXV 32-510 O-ITT	2.2 X2
BS2V 2 MXV 32-512 O-ITT	3 X2
BS2V 2 MXV 40-904 O-ITT	1.5 X2
BS2V 2 MXV 40-905 O-ITT	2.2 X2
BS2V 2 MXV 40-906 O-ITT	2.2 X2
BS2V 2 MXV 40-907 O-ITT	3 X2
BS2V 2 MXV 40-908 O-ITT	3 X2
BS2V 2 MXV 40-910 O-ITT	4 X2
BS2V 2 MXV 40-911 O-ITT	4 X2
BS2V 2 MXV 50-1503/A-ITT	2.2 X2
BS2V 2 MXV 50-1504-ITT	3 X2
BS2V 2 MXV 50-1505-ITT	4 X2
BS2V 2 MXV 50-1506-ITT	5.5 X2
BS2V 2 MXV 50-1507-ITT	5.5 X2
BS2V 2 MXV 50-1508/A-ITT	5.5 X2
BS2V 2 MXV 50-1509-ITT	7.5 X2
BS2V 2 MXV 50-1510-ITT	7.5 X2
BS2V 2 MXV 50-2003-ITT	3 X2
BS2V 2 MXV 50-2004-ITT	4 X2
BS2V 2 MXV 50-2005-ITT	5.5 X2
BS2V 2 MXV 50-2006-ITT	7.5 X2
BS2V 2 MXV 50-2007-ITT	7.5 X2
BS2V 2 MXV 50-2008-ITT	9.2 X2
BS2V 2 MXV 50-2009-ITT	9.2 X2
BS2V 2 MXV 65-3202/D-ITT	4 X2
BS2V 2 MXV 65-3203/C-ITT	5.5 X2
BS2V 2 MXV 65-3204/C-ITT	7.5 X2
BS2V 2 MXV 65-3205/D-ITT	11 X2
BS2V 2 MXV 65-3206/D-ITT	11 X2
BS2V 2 MXV 65-3207/D-ITT	15 X2
BS2V 2 MXV 80-4802/C-ITT	5.5 X2
BS2V 2 MXV 80-4803/C-ITT	7.5 X2
BS2V 2 MXV 80-4804/D-ITT	11 X2
BS2V 2 MXV 80-4805/D-ITT	15 X2
BS2V 2 MXV 80-4806/D-ITT	15 X2
BS2V 2 MXV 80-4807/E-ITT	18.5 X2
BS2V 2 MXV 100-6501/A-ITT	5.5 X2
BS2V 2 MXV 100-6502-2R/A-ITT	7.5 X2
BS2V 2 MXV 100-6502/A-ITT	11 X2
BS2V 2 MXV 100-6503-2R/A-ITT	15 X2
BS2V 2 MXV 100-6503/B-ITT	18.5 X2
BS2V 2 MXV 100-6504-2R/B-ITT	18.5 X2
BS2V 2 MXV 100-6504/A-ITT	22 X2
BS2V 2 MXV 100-9001/A-ITT	7.5 X2
BS2V 2 MXV 100-9002-2R/A-ITT	11 X2
BS2V 2 MXV 100-9002/A-ITT	15 X2
BS2V 2 MXV 100-9003-2R/B-ITT	18.5 X2
BS2V 2 MXV 100-9003/A-ITT	22 X2

## BSM3V ...ITT

Model	P2 kW
BS3V 3 MXV 25-304 O-ITT	0.75 X3
BS3V 3 MXV 25-305 O-ITT	0.75 X3
BS3V 3 MXV 25-306 O-ITT	1.1 X3
BS3V 3 MXV 25-307 O-ITT	1.1 X3
BS3V 3 MXV 25-308 O-ITT	1.5 X3
BS3V 3 MXV 25-310 O-ITT	1.5 X3
BS3V 3 MXV 25-312 O-ITT	2.2 X3
BS3V 3 MXV 32-504 O-ITT	1.1 X3
BS3V 3 MXV 32-505 O-ITT	1.1 X3
BS3V 3 MXV 32-506 O-ITT	1.5 X3
BS3V 3 MXV 32-507 O-ITT	1.5 X3
BS3V 3 MXV 32-508 O-ITT	2.2 X3
BS3V 3 MXV 32-510 O-ITT	2.2 X3
BS3V 3 MXV 32-512 O-ITT	3 X3
BS3V 3 MXV 40-904 O-ITT	1.5 X3
BS3V 3 MXV 40-905 O-ITT	2.2 X3
BS3V 3 MXV 40-906 O-ITT	2.2 X3
BS3V 3 MXV 40-907 O-ITT	3 X3
BS3V 3 MXV 40-908 O-ITT	3 X3
BS3V 3 MXV 40-910 O-ITT	4 X3
BS3V 3 MXV 40-911 O-ITT	4 X3
BS3V 3 MXV 50-1503/A-ITT	2.2 X3
BS3V 3 MXV 50-1504-ITT	3 X3
BS3V 3 MXV 50-1505-ITT	4 X3
BS3V 3 MXV 50-1506-ITT	5.5 X3
BS3V 3 MXV 50-1507-ITT	5.5 X3
BS3V 3 MXV 50-1508/A-ITT	5.5 X3
BS3V 3 MXV 50-1509-ITT	7.5 X3
BS3V 3 MXV 50-1510-ITT	7.5 X3
BS3V 3 MXV 50-2003-ITT	3 X3
BS3V 3 MXV 50-2004-ITT	4 X3
BS3V 3 MXV 50-2005-ITT	5.5 X3
BS3V 3 MXV 50-2006-ITT	7.5 X3
BS3V 3 MXV 50-2007-ITT	7.5 X3
BS3V 3 MXV 50-2008-ITT	9.2 X3
BS3V 3 MXV 50-2009-ITT	9.2 X3
BS3V 3 MXV 65-3202/D-ITT	4 X3
BS3V 3 MXV 65-3203/C-ITT	5.5 X3
BS3V 3 MXV 65-3204/C-ITT	7.5 X3
BS3V 3 MXV 65-3205/D-ITT	11 X3
BS3V 3 MXV 65-3206/D-ITT	11 X3
BS3V 3 MXV 65-3207/D-ITT	15 X3
BS3V 3 MXV 80-4802/C-ITT	5.5 X3
BS3V 3 MXV 80-4803/C-ITT	7.5 X3
BS3V 3 MXV 80-4804/D-ITT	11 X3
BS3V 3 MXV 80-4805/D-ITT	15 X3
BS3V 3 MXV 80-4806/D-ITT	15 X3
BS3V 3 MXV 80-4807/E-ITT	18.5 X3
BS3V 3 MXV 100-6501/A-ITT	5.5 X3
BS3V 3 MXV 100-6502-2R/A-ITT	7.5 X3
BS3V 3 MXV 100-6502/A-ITT	11 X3
BS3V 3 MXV 100-6503-2R/A-ITT	15 X3
BS3V 3 MXV 100-6503/B-ITT	18.5 X3
BS3V 3 MXV 100-6504-2R/B-ITT	18.5 X3
BS3V 3 MXV 100-6504/A-ITT	22 X3
BS3V 3 MXV 100-9001/A-ITT	7.5 X3
BS3V 3 MXV 100-9002-2R/A-ITT	11 X3
BS3V 3 MXV 100-9002/A-ITT	15 X3
BS3V 3 MXV 100-9003-2R/B-ITT	18.5 X3
BS3V 3 MXV 100-9003/A-ITT	22 X3

BS, MXV



### Variable speed pump units with WALL

#### BS2V ...-WALL

Model	P2
	kW
BS2V 2 MXV 50-1504-WALL	3 X2
BS2V 2 MXV 50-1505-WALL	4 X2
BS2V 2 MXV 50-1506-WALL	5.5 X2
BS2V 2 MXV 50-1507-WALL	5.5 X2
BS2V 2 MXV 50-1508/A-WALL	5.5 X2
BS2V 2 MXV 50-1509-WALL	7.5 X2
BS2V 2 MXV 50-1510-WALL	7.5 X2
BS2V 2 MXV 50-1512-WALL	9.2 X2
BS2V 2 MXV 50-1515-WALL	11 X2
BS2V 2 MXV 50-1517-WALL	15 X2
BS2V 2 MXV 50-2003-WALL	3 X2
BS2V 2 MXV 50-2004-WALL	4 X2
BS2V 2 MXV 50-2005-WALL	5.5 X2
BS2V 2 MXV 50-2006-WALL	7.5 X2
BS2V 2 MXV 50-2007-WALL	7.5 X2
BS2V 2 MXV 50-2008-WALL	9.2 X2
BS2V 2 MXV 50-2009-WALL	9.2 X2
BS2V 2 MXV 50-2011-WALL	11 X2
BS2V 2 MXV 50-2015-WALL	15 X2

## Dimensions and weights

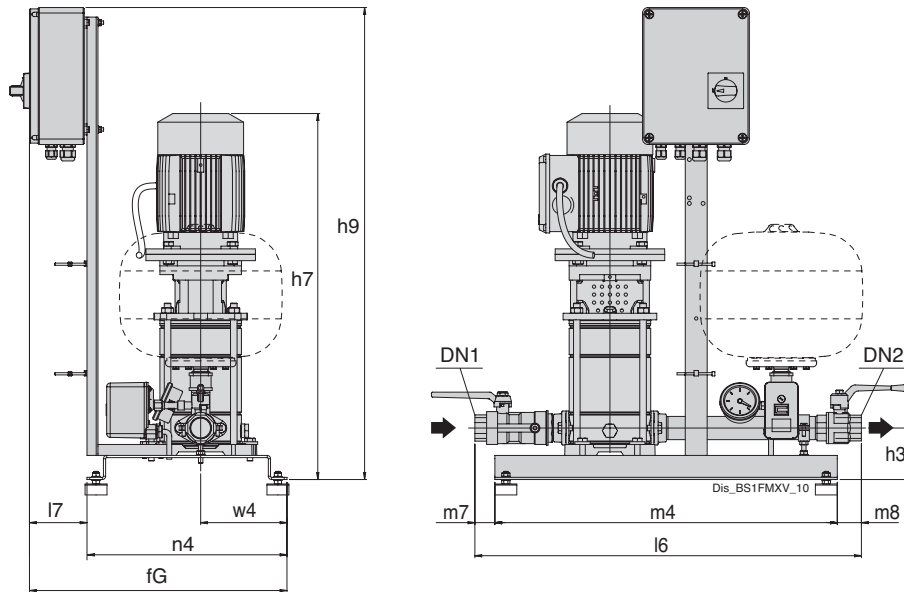

TYPE	mm											kg
	DN1	DN2	fG	h3	h7	h9	l6	l7	m4	n4	w4	Weight
BS1F1MXV25-304O	G 1	G 1	470	94	666	862	651	105	625	365	158	44.5
BS1F1MXV25-305O	G 1	G 1	470	94	690	862	651	105	625	365	158	53.8
BS1F1MXV25-306O	G 1	G 1	470	94	714	862	651	105	625	365	158	48.3
BS1F1MXV25-307O	G 1	G 1	470	94	738	862	651	105	625	365	158	53.8
BS1F1MXV25-308O	G 1	G 1	470	94	762	862	651	105	625	365	158	55.8
BS1F1MXV25-310O	G 1	G 1	470	94	811	862	651	105	625	365	158	53.8
BS1F1MXV25-312O	G 1	G 1	470	94	899	862	651	105	625	365	158	53.8
BS1F1MXV32-504O	G 1 1/4	G 1 1/4	470	94	666	862	706	105	625	365	158	53.8
BS1F1MXV32-505O	G 1 1/4	G 1 1/4	470	94	690	862	706	105	625	365	158	53.8
BS1F1MXV32-506O	G 1 1/4	G 1 1/4	470	94	714	862	706	105	625	365	158	51.1
BS1F1MXV32-507O	G 1 1/4	G 1 1/4	470	94	738	862	706	105	625	365	158	-
BS1F1MXV32-508O	G 1 1/4	G 1 1/4	470	94	802	862	706	105	625	365	158	55.4
BS1F1MXV32-510O	G 1 1/4	G 1 1/4	470	94	851	862	706	105	625	365	158	56.6
BS1F1MXV32-512O	G 1 1/4	G 1 1/4	470	94	915	862	706	105	625	365	158	53.8
BS1F1MXV40-904O	G 1 1/2	G 1 1/2	470	124	711	862	706	105	625	365	160	53.8
BS1F1MXV40-905O	G 1 1/2	G 1 1/2	470	124	781	862	706	105	625	365	160	53.8
BS1F1MXV40-906O	G 1 1/2	G 1 1/2	470	124	811	862	706	105	625	365	160	60
BS1F1MXV40-907O	G 1 1/2	G 1 1/2	470	124	857	862	706	105	625	365	160	53.8
BS1F1MXV40-908O	G 1 1/2	G 1 1/2	470	124	887	862	706	105	625	365	160	53.8
BS1F1MXV40-910O	G 1 1/2	G 1 1/2	470	124	947	862	706	105	625	365	160	53.8
BS1F1MXV40-911O	G 1 1/2	G 1 1/2	470	124	977	862	706	105	625	365	160	53.8

Non-binding dimensions to be checked when ordering  
 Anti-vibration kit supplied disassembled as standard

TYPE	ISO 228		mm									Kg
	DN1	DN2	fG	h3	h7	h9	l6	l7	m4	n4	w4	Weight
BSM1F1MXVM25-304O	G 1	G 1	470	94	666	862	790	105	625	365	158	42.3
BSM1F1MXVM25-305O	G 1	G 1	470	94	690	862	790	105	625	365	158	42.3
BSM1F1MXVM25-306O	G 1	G 1	470	94	714	862	790	105	625	365	158	42.3
BSM1F1MXVM25-307O	G 1	G 1	470	94	738	862	790	105	625	365	158	42.3
BSM1F1MXVM25-308O	G 1	G 1	470	94	762	862	790	105	625	365	158	42.3
BSM1F1MXVM32-504O	G 1 1/4	G 1 1/4	470	94	666	862	790	105	625	365	158	42.3
BSM1F1MXVM32-505O	G 1 1/4	G 1 1/4	470	94	690	862	790	105	625	365	158	42.3
BSM1F1MXVM32-506O	G 1 1/4	G 1 1/4	470	94	714	862	790	105	625	365	158	42.3
BSM1F1MXVM32-507O	G 1 1/4	G 1 1/4	470	94	738	862	790	105	625	365	158	42.3
BSM1F1MXVM40-904O	G 1 1/2	G 1 1/2	470	94	802	862	790	105	625	365	158	42.3

Non-binding dimensions to be checked when ordering  
 Anti-vibration kit supplied disassembled as standard

## Dimensions and weights

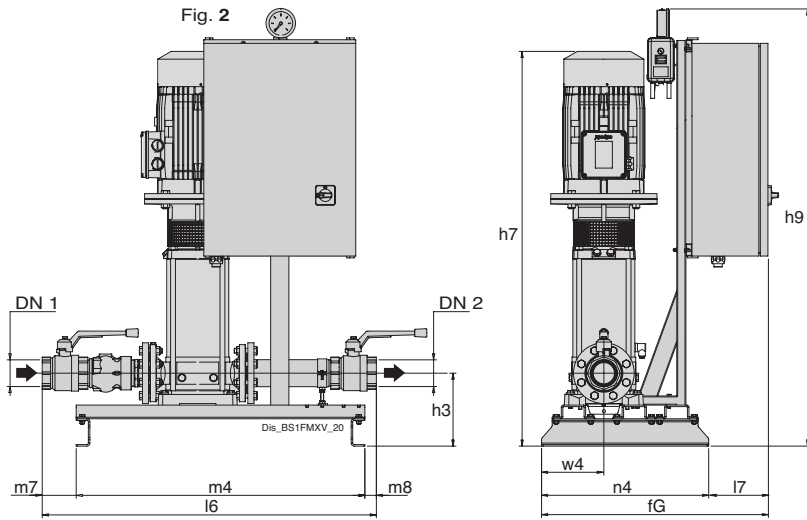

TYPE	Manifolds		mm									Kg Weight
	DN1	DN2	fG	h3	h7	h9	l6	l7	m4	n4	w4	
BS1F 1 MXV 50-1503/A	G 2	G 2	550	225	934	1155	919	-	950	550	205	55.4
BS1F 1 MXV 50-1504	G 2	G 2	550	225	980	1155	919	-	950	550	205	107
BS1F 1 MXV 50-1505	G 2	G 2	550	225	1028	1155	919	-	950	550	205	103
BS1F 1 MXV 50-1506	G 2	G 2	550	225	1167	1155	919	-	950	550	205	55.4
BS1F 1 MXV 50-1507	G 2	G 2	550	225	1215	1155	919	-	950	550	205	-
BS1F 1 MXV 50-1508/A	G 2	G 2	695	225	1263	1420	919	145	950	550	205	55.4
BS1F 1 MXV 50-1509	G 2	G 2	695	225	1311	1420	919	145	950	550	205	55.4
BS1F 1 MXV 50-1510	G 2	G 2	695	225	1359	1420	919	145	950	550	205	55.4
BS1F 1 MXV 50-2003	G 2	G 2	550	225	932	1155	919	-	950	550	205	55.4
BS1F 1 MXV 50-2004	G 2	G 2	550	225	967	1155	919	-	950	550	205	110
BS1F 1 MXV 50-2005	G 2	G 2	550	225	1119	1155	919	-	950	550	205	55.4
BS1F 1 MXV 50-2006	G 2	G 2	695	225	1167	1420	919	145	950	550	205	165
BS1F 1 MXV 50-2007	G 2	G 2	65	225	1215	1420	919	145	950	550	205	55.4
BS1F 1 MXV 50-2008	G 2	G 2	695	225	1367	1420	919	145	950	550	205	55.4
BS1F 1 MXV 50-2009	G 2	G 2	695	225	1415	1420	919	145	950	550	205	55.4
BS1F 1 MXV 65-3202/D	G 2 1/2	G 2 1/2	550	240	853	1155	1042	-	950	550	205	119
BS1F 1 MXV 65-3203/C	G 2 1/2	G 2 1/2	550	240	947	1155	1042	-	950	550	205	53.8
BS1F 1 MXV 65-3204/C	G 2 1/2	G 2 1/2	695	240	993	1420	1042	145	950	550	205	178
BS1F 1 MXV 65-3205/D	G 2 1/2	G 2 1/2	695	240	1189	1420	1042	145	950	550	205	228.5
BS1F 1 MXV 65-3206/D	G 2 1/2	G 2 1/2	695	240	1235	1420	1042	145	950	550	205	221
BS1F 1 MXV 65-3207/D	G 2 1/2	G 2 1/2	695	240	1306	1420	1042	145	950	550	205	245.5
BS1F 1 MXV 80-4802/C	G 3	G 3	550	240	940	1155	1100	-	950	550	205	53.8
BS1F 1 MXV 80-4803/C	G 3	G 3	695	240	1001	1420	1100	145	950	550	205	53.8
BS1F 1 MXV 80-4804/D	G 3	G 3	695	240	1212	1420	1100	145	950	550	205	53.8
BS1F 1 MXV 80-4805/D	G 3	G 3	695	240	1299	1420	1100	145	950	550	205	53.8
BS1F 1 MXV 80-4806/D	G 3	G 3	695	240	1360	1420	1100	145	950	550	205	53.8
BS1F 1 MXV 80-4807/E	G 3	G 3	695	240	1498	1420	1100	145	950	550	205	53.8

Non-binding dimensions to be checked when ordering

## Dimensions and weights

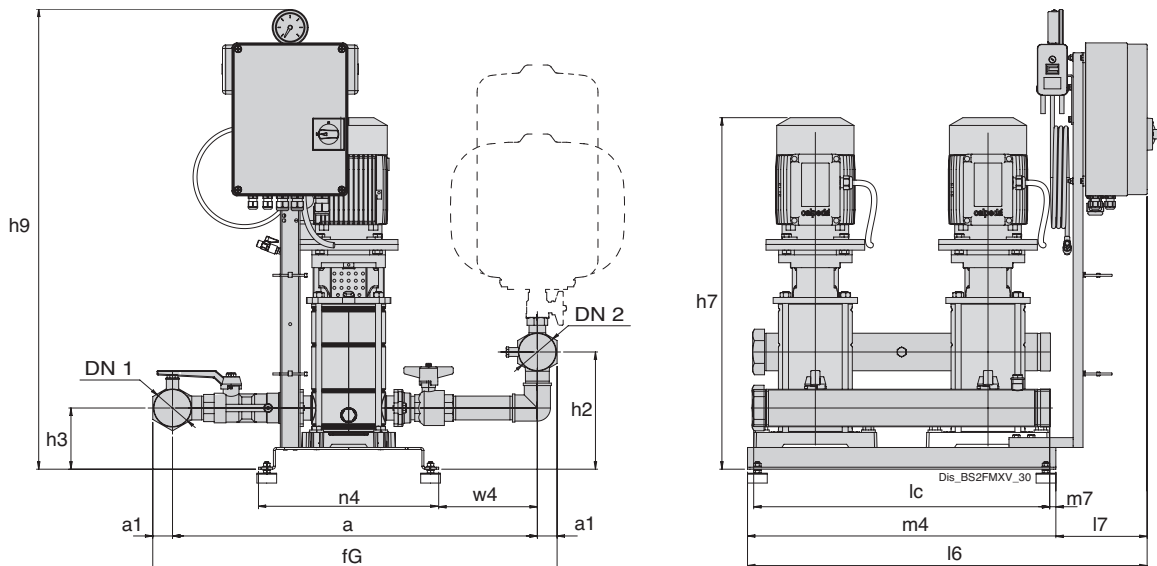

TYPE	Manifolds		mm													Kg Weight
	DN1	DN2	a	a1	fG	h2	h3	h7	h9	l6	l7	lc	m4	n4	w4	
BS2F 2 MXV 25-304 O	G 1 1/2	G 1 1/2	589	26.5	642	170	94	666	864	810	185	600	625	365	140	-
BS2F 2 MXV 25-305 O	G 1 1/2	G 1 1/2	589	26.5	642	170	94	690	864	810	185	600	625	365	140	-
BS2F 2 MXV 25-306 O	G 1 1/2	G 1 1/2	589	26.5	642	170	94	714	864	810	185	600	625	365	140	87.7
BS2F 2 MXV 25-307 O	G 1 1/2	G 1 1/2	589	26.5	642	170	94	738	864	810	185	600	625	365	140	-
BS2F 2 MXV 25-308 O	G 1 1/2	G 1 1/2	589	26.5	642	170	94	762	864	810	185	600	625	365	140	-
BS2F 2 MXV 25-310 O	G 1 1/2	G 1 1/2	589	26.5	642	170	94	811	864	810	185	600	625	365	140	-
BS2F 2 MXV 25-312 O	G 1 1/2	G 1 1/2	589	26.5	642	170	94	899	864	810	185	600	625	365	140	-
BS2F 2 MXV 32-504 O	G 2	G 2	642	32	706	186	94	666	864	810	185	600	625	365	168	86.9
BS2F 2 MXV 32-505 O	G 2	G 2	642	32	706	186	94	690	864	810	185	600	625	365	168	-
BS2F 2 MXV 32-506 O	G 2	G 2	642	32	706	186	94	714	864	810	185	600	625	365	168	93.3
BS2F 2 MXV 32-507 O	G 2	G 2	642	32	706	186	94	738	864	810	185	600	625	365	168	94.5
BS2F 2 MXV 32-508 O	G 2	G 2	642	32	706	186	94	802	864	810	185	600	625	365	168	-
BS2F 2 MXV 32-510 O	G 2	G 2	642	32	706	186	94	851	864	810	185	600	625	365	168	103
BS2F 2 MXV 32-512 O	G 2	G 2	642	32	706	186	94	915	864	810	185	600	625	365	168	-
BS2F 2 MXV 40-904 O	G 2 1/2	G 2 1/2	706	40	820	238	124	711	931	810	185	600	625	365	200	-
BS2F 2 MXV 40-905 O	G 2 1/2	G 2 1/2	706	40	820	238	124	781	931	810	185	600	625	365	200	-
BS2F 2 MXV 40-906 O	G 2 1/2	G 2 1/2	706	40	820	238	124	811	931	810	185	600	625	365	200	110.9
BS2F 2 MXV 40-907 O	G 2 1/2	G 2 1/2	706	40	820	238	124	857	931	810	185	600	625	365	200	128
BS2F 2 MXV 40-908 O	G 2 1/2	G 2 1/2	706	40	820	238	124	887	931	810	185	600	625	365	200	-
BS2F 2 MXV 40-910 O	G 2 1/2	G 2 1/2	706	40	820	238	124	947	931	810	185	600	625	365	200	139.5
BS2F 2 MXV 40-911 O	G 2 1/2	G 2 1/2	706	40	820	170	94	977	1012	810	185	600	625	365	200	-

Non-binding dimensions to be checked when ordering  
 Anti-vibration kit supplied disassembled as standard

## Dimensions and weights

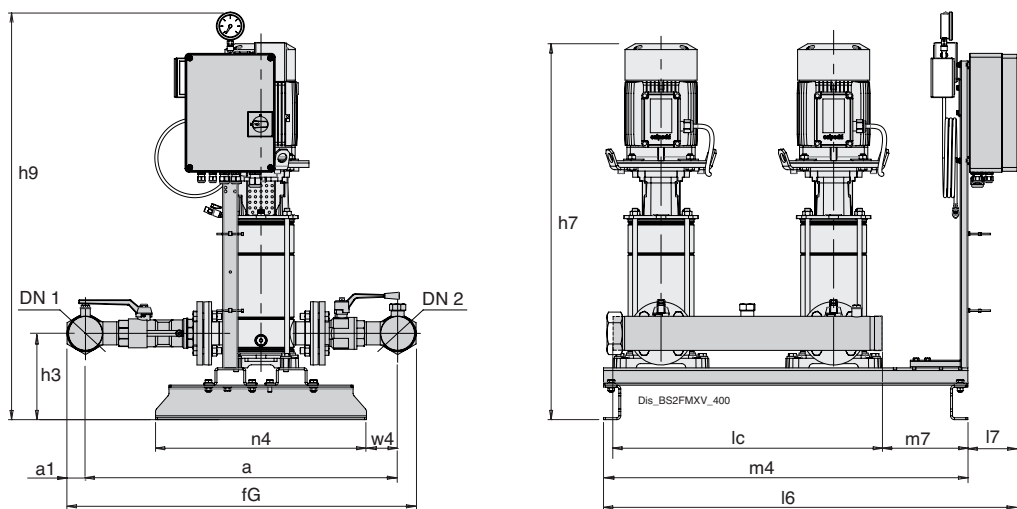

TYPE	Manifolds		mm												Kg Weight
	DN1	DN2	a	a1	fG	h3	h7	h9	l6	l7	lc	m4	n4	w4	
BS2F 2 MXV 50-1503/A	G 3	G 3	816	48	913	225	934	1015	1080	130	700	950	550	82	52.4
BS2F 2 MXV 50-1504	G 3	G 3	816	48	913	225	980	1015	1080	130	700	950	550	82	174.5
BS2F 2 MXV 50-1505	G 3	G 3	816	48	913	225	1028	1015	1080	130	700	950	550	82	52.4
BS2F 2 MXV 50-1506	G 3	G 3	816	48	913	225	1167	1015	1080	130	700	950	550	82	236
BS2F 2 MXV 50-1507	G 3	G 3	816	48	913	225	1215	1015	1080	130	700	950	550	82	241
BS2F 2 MXV 50-1508/A	G 3	G 3	816	48	913	225	1263	1420	1170	220	700	950	550	82	52.4
BS2F 2 MXV 50-1509	G 3	G 3	816	48	913	225	1311	1420	1170	220	700	950	550	82	-
BS2F 2 MXV 50-1510	G 3	G 3	816	48	913	225	1359	1420	1170	220	700	950	550	82	290
BS2F 2 MXV 50-2003	G 3	G 3	816	48	913	225	932	1015	1112	130	700	950	550	82	52.4
BS2F 2 MXV 50-2004	G 3	G 3	816	48	913	225	967	1015	1112	130	700	950	550	82	181.5
BS2F 2 MXV 50-2005	G 3	G 3	816	48	913	225	1119	1015	1112	130	700	950	550	82	227
BS2F 2 MXV 50-2006	G 3	G 3	816	48	913	225	1167	1420	1202	220	700	950	550	82	278
BS2F 2 MXV 50-2007	G 3	G 3	816	48	913	225	1215	1420	1202	220	700	950	550	82	52.4
BS2F 2 MXV 50-2008	G 3	G 3	816	48	913	225	1367	1420	1202	220	700	950	550	82	52.4
BS2F 2 MXV 50-2009	G 3	G 3	816	48	913	225	1415	1420	1202	220	700	950	550	82	52.4

Non-binding dimensions to be checked when ordering

## Dimensions and weights

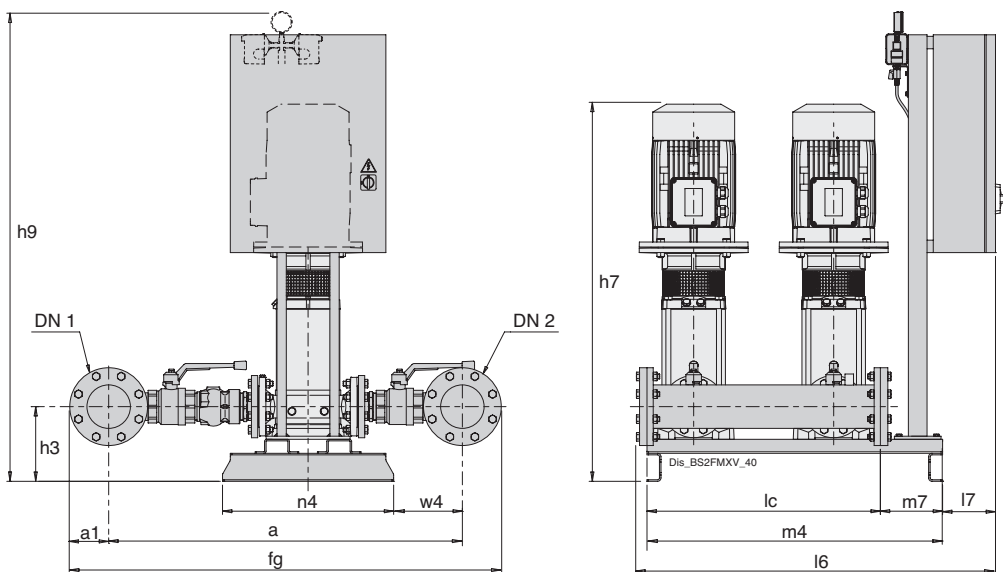

TYPE	Manifolds		mm											Kg Weight	
	DN1	DN2	a	a1	fG	h3	h7	h9	l6	l7	lc	m4	n4		w4
BS2F 2 MXV 65-3202/D	100	100	1090	110	1310	240	853	1015	1114	130	750	950	550	231	271
BS2F 2 MXV 65-3203/C	100	100	1090	110	1310	240	947	1015	1114	130	750	950	550	231	304
BS2F 2 MXV 65-3204/C	100	100	1090	110	1310	240	993	1420	1204	220	750	950	550	231	354
BS2F 2 MXV 65-3205/D	100	100	1090	110	1310	240	1189	1420	1204	220	750	950	550	231	-
BS2F 2 MXV 65-3206/D	100	100	1090	110	1310	240	1235	1420	1204	220	750	950	550	231	436.5
BS2F 2 MXV 65-3207/D	100	100	1090	110	1310	240	1306	1420	1204	220	750	950	550	231	107.5
BS2F 2 MXV 80-4802/C	125	125	1191	125	1441	240	940	1015	1080	130	750	950	550	279	-
BS2F 2 MXV 80-4803/C	125	125	1191	125	1441	240	1001	1420	1170	220	750	950	550	279	-
BS2F 2 MXV 80-4804/D	125	125	1191	125	1441	240	1212	1420	1170	220	750	950	550	279	471
BS2F 2 MXV 80-4805/D	125	125	1191	125	1441	240	1299	1420	1170	220	750	950	550	279	-
BS2F 2 MXV 80-4806/D	125	125	1191	125	1441	240	1360	1420	1170	220	750	950	550	279	534
BS2F 2 MXV 80-4807/E	125	125	1191	125	1441	240	1498	1420	1170	220	750	950	550	279	534
BS2F 2 MXV 100-6502-2R/A	150	150	-	142.5	-	-	1394	-	-	-	950	-	-	-	107.5
BS2F 2 MXV 100-6502/A	150	150	-	142.5	-	-	1534	-	-	-	950	-	-	-	107.5
BS2F 2 MXV 100-6503-2R/A	150	150	-	142.5	-	-	1651	-	-	-	950	-	-	-	107.5
BS2F 2 MXV 100-6503/B	150	150	-	142.5	-	-	1705	-	-	-	950	-	-	-	107.5
BS2F 2 MXV 100-6504-2R/B	150	150	-	142.5	-	-	1797	-	-	-	950	-	-	-	107.5
BS2F 2 MXV 100-6504/A	150	150	-	142.5	-	-	1797	-	-	-	950	-	-	-	107.5
BS2F 2 MXV 100-6505-2R/A	150	150	-	142.5	-	-	1968	-	-	-	950	-	-	-	107.5
BS2F 2 MXV 100-6505/A	150	150	-	142.5	-	-	1968	-	-	-	950	-	-	-	107.5
BS2F 2 MXV 100-9002-2R/A	200	200	1543	170	1883	370	1538	-	-	-	950	1300	1050	260	107.5
BS2F 2 MXV 100-9002/A	200	200	1543	170	1883	370	1563	-	-	-	950	1300	1050	260	107.5
BS2F 2 MXV 100-9003-2R/B	200	200	1543	170	1883	370	1709	-	-	-	950	1300	1050	260	107.5
BS2F 2 MXV 100-9003/A	200	200	1543	170	1883	370	1709	-	-	-	950	1300	1050	260	107.5
BS2F 2 MXV 100-9004-2R/A	200	200	1543	170	1883	370	1904	-	-	-	950	1300	1050	260	107.5
BS2F 2 MXV 100-9004/A	200	200	1543	170	1883	370	1904	-	-	-	950	1300	1050	260	107.5
BS2F 2 MXV 100-9005-2R/A	200	200	1543	170	1883	370	1997	-	-	-	950	1300	1050	260	107.5

Non-binding dimensions to be checked when ordering  
Missing dimensions on request



## Dimensions and weights

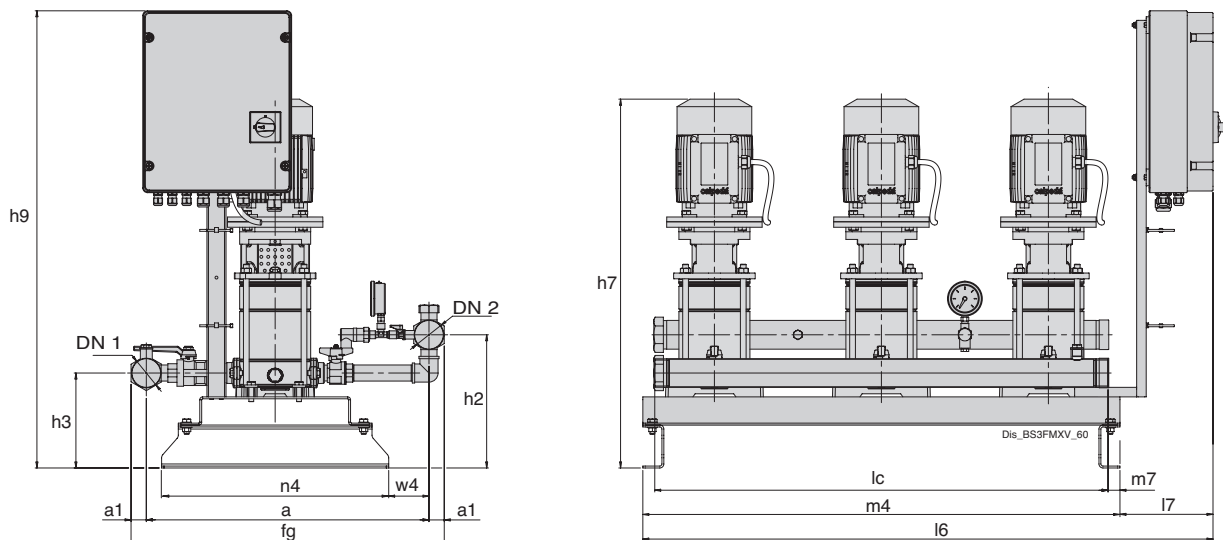

TYPE	Manifolds		mm													Kg Weight
	DN1	DN2	a	a1	fG	h2	h3	h7	h9	l6	l7	lc	m4	n4	w4	
BS3F 3 MXV 25-304 O	G 2	G 2	593	32	657	279	199	771	969	1195	195	950	1000	476	84	136
BS3F 3 MXV 25-305 O	G 2	G 2	593	32	657	279	199	795	969	1195	195	950	1000	476	84	136
BS3F 3 MXV 25-306 O	G 2	G 2	593	32	657	279	199	819	969	1195	195	950	1000	476	84	136
BS3F 3 MXV 25-307 O	G 2	G 2	593	32	657	279	199	843	969	1195	195	950	1000	476	84	136
BS3F 3 MXV 25-308 O	G 2	G 2	593	32	657	279	199	867	969	1195	195	950	1000	476	84	136
BS3F 3 MXV 25-310 O	G 2	G 2	593	32	657	279	199	916	969	1195	195	950	1000	476	84	136
BS3F 3 MXV 25-312 O	G 2	G 2	593	32	657	279	199	1004	969	1195	195	950	1000	476	84	136
BS3F 3 MXV 32-504 O	G 2 1/2	G 2 1/2	650	40	730	299	199	771	969	1195	195	950	1000	476	113	136
BS3F 3 MXV 32-505 O	G 2 1/2	G 2 1/2	650	40	730	299	199	795	969	1195	195	950	1000	476	113	136
BS3F 3 MXV 32-506 O	G 2 1/2	G 2 1/2	650	40	730	299	199	918	969	1195	195	950	1000	476	113	136
BS3F 3 MXV 32-507 O	G 2 1/2	G 2 1/2	650	40	730	299	199	843	969	1195	195	950	1000	476	113	136
BS3F 3 MXV 32-508 O	G 2 1/2	G 2 1/2	650	40	730	299	199	907	969	1195	195	950	1000	476	113	136
BS3F 3 MXV 32-510 O	G 2 1/2	G 2 1/2	650	40	730	299	199	956	969	1195	195	950	1000	476	113	136
BS3F 3 MXV 32-512 O	G 2 1/2	G 2 1/2	650	40	730	299	199	1020	969	1195	195	950	1000	476	113	136
BS3F 3 MXV 40-904 O	G 3	G 3	746	48	842	349	229	816	969	1195	195	950	1000	476	145	136
BS3F 3 MXV 40-905 O	G 3	G 3	746	48	842	349	229	886	969	1195	195	950	1000	476	145	136
BS3F 3 MXV 40-906 O	G 3	G 3	746	48	842	349	229	916	969	1195	195	950	1000	476	145	136
BS3F 3 MXV 40-907 O	G 3	G 3	746	48	842	349	229	962	969	1195	195	950	1000	476	145	136
BS3F 3 MXV 40-908 O	G 3	G 3	746	48	842	349	229	992	969	1195	195	950	1000	476	145	224
BS3F 3 MXV 40-910 O	G 3	G 3	746	48	842	349	229	1052	969	1195	195	950	1000	476	145	136
BS3F 3 MXV 40-911 O	G 3	G 3	746	48	842	349	229	1082	969	1195	195	950	1000	476	145	136

Non-binding dimensions to be checked when ordering

## Dimensions and weights

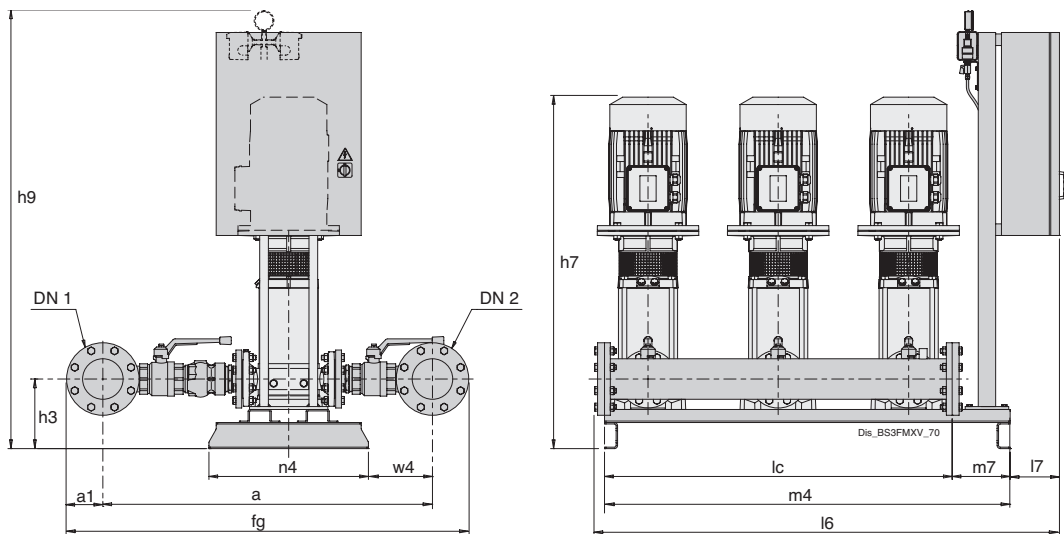

TYPE	Manifolds		mm												Kg Weight
	DN1	DN2	a	a1	fG	h3	h7	h9	l6	l7	lc	m4	n4	w4	
BS3F 3 MXV 50-1503/A	100	100	880	110	1100	296	1005	1020	1572	140	1200	1400	550	94	194
BS3F 3 MXV 50-1504	100	100	880	110	1100	296	1051	1020	1572	140	1200	1400	550	94	339
BS3F 3 MXV 50-1505	100	100	880	110	1100	296	1099	1020	1572	140	1200	1400	550	94	194
BS3F 3 MXV 50-1506	100	100	880	110	1100	296	1239	1220	1572	140	1200	1400	550	94	194
BS3F 3 MXV 50-1507	100	100	880	110	1100	296	1287	1220	1572	140	1200	1400	550	94	194
BS3F 3 MXV 50-1508/A	100	100	880	110	1100	296	1335	1408	1652	220	1200	1400	550	94	486
BS3F 3 MXV 50-1509	100	100	880	110	1100	296	1382	1408	1652	220	1200	1400	550	94	194
BS3F 3 MXV 50-1510	100	100	880	110	1100	296	1430	1408	1652	220	1200	1400	550	94	194
BS3F 3 MXV 50-2003	100	100	880	110	1100	296	1003	1020	1572	140	1200	1400	550	94	194
BS3F 3 MXV 50-2004	100	100	880	110	1100	296	1038	1020	1572	140	1200	1400	550	94	194
BS3F 3 MXV 50-2005	100	100	880	110	1100	296	1190	1020	1572	140	1200	1400	550	94	194
BS3F 3 MXV 50-2006	100	100	880	110	1100	296	1238	1408	1572	140	1200	1400	550	94	194
BS3F 3 MXV 50-2007	100	100	880	110	1100	296	1286	1408	1572	140	1200	1400	550	94	482
BS3F 3 MXV 50-2008	100	100	880	110	1100	296	1438	-	1652	220	1200	1400	550	94	194
BS3F 3 MXV 50-2009	100	100	880	110	1100	296	1486	-	1652	220	1200	1400	550	94	194
BS3F 3 MXV 65-3202/D	125	125	1156	125	1406	291	903	1500	1574	140	1200	1400	550	284	-
BS3F 3 MXV 65-3203/C	125	125	1156	125	1406	291	997	1500	1574	140	1200	1400	550	284	-
BS3F 3 MXV 65-3204/C	125	125	1156	125	1406	291	1043	1500	1574	140	1200	1400	550	284	-
BS3F 3 MXV 65-3205/D	125	125	1156	125	1406	291	1239	1713	1654	220	1200	1400	550	284	-
BS3F 3 MXV 65-3206/D	125	125	1156	125	1406	291	1285	1713	1654	220	1200	1400	550	284	-
BS3F 3 MXV 65-3207/D	125	125	1156	125	1406	291	1356	1713	1654	220	1200	1400	550	284	-
BS3F 3 MXV 80-4802/C	150	150	1240	142.5	1525	291	990	1500	1577	140	1200	1400	550	313	-
BS3F 3 MXV 80-4803/C	150	150	1240	142.5	1525	291	1051	1500	1577	140	1200	1400	550	313	-
BS3F 3 MXV 80-4804/D	150	150	1240	142.5	1525	291	1262	1713	1657	220	1200	1400	550	313	-
BS3F 3 MXV 80-4805/D	150	150	1240	142.5	1525	291	1349	1713	1657	220	1200	1400	550	313	-
BS3F 3 MXV 80-4806/D	150	150	1240	142.5	1525	291	1410	1713	1657	220	1200	1400	550	313	-
BS3F 3 MXV 80-4807/E	150	150	1240	142.5	1525	291	1548	1713	-	-	1200	1400	550	313	-
BS3F 3 MXV 100-6502-2R/A	200	200	1318	170	1658	386	1414	-	-	-	1500	1650	900	65	-
BS3F 3 MXV 100-6502/A	200	200	1318	170	1658	386	1554	-	-	-	1500	1650	900	65	-
BS3F 3 MXV 100-6503-2R/A	200	200	1318	170	1658	386	1671	-	-	-	1500	1650	900	65	-
BS3F 3 MXV 100-6503/B	200	200	1318	170	1658	386	1725	-	-	-	1500	1650	900	65	-
BS3F 3 MXV 100-6504-2R/B	200	200	1318	170	1658	386	1817	-	-	-	1500	1650	900	65	-
BS3F 3 MXV 100-6504/A	200	200	1318	170	1658	386	1817	-	-	-	1500	1650	900	65	-
BS3F 3 MXV 100-6505-2R/A	200	200	1318	170	1658	386	1988	-	-	-	1500	1650	900	65	-
BS3F 3 MXV 100-6505/A	200	200	1318	170	1658	386	1988	-	-	-	1500	1650	900	65	-
BS3F 3 MXV 100-9002-2R/A	200	200	1561	170	1901	390	1988	-	-	-	1500	1850	1050	280	-
BS3F 3 MXV 100-9002/A	200	200	1561	170	1901	390	1558	-	-	-	1500	1850	1050	280	-
BS3F 3 MXV 100-9003-2R/B	200	200	1561	170	1901	390	1583	-	-	-	1500	1850	1050	280	-
BS3F 3 MXV 100-9003/A	200	200	1561	170	1901	390	1729	-	-	-	1500	1850	1050	280	-
BS3F 3 MXV 100-9004-2R/A	200	200	1561	170	1901	390	1924	-	-	-	1500	1850	1050	280	-
BS3F 3 MXV 100-9004/A	200	200	1561	170	1901	390	1729	-	-	-	1500	1850	1050	280	-
BS3F 3 MXV 100-9005-2R/A	200	200	1561	170	1901	390	1924	-	-	-	1500	1850	1050	280	-

Non-binding dimensions to be checked when ordering  
Missing dimensions on request

## Dimensions and weights

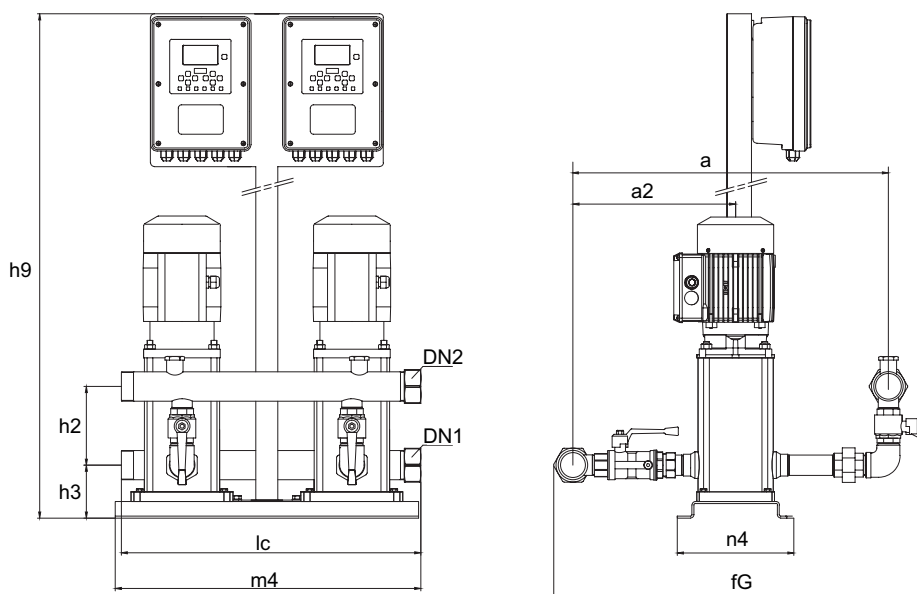

TYPE	Manifolds		mm									Kg Weight
	DN1	DN2	a	a2	fG	h2	h3	h9	lc	m4	n4	
BS2V 2 MXV 50-1504-WALL	G 3	G 3	825	495	920	148	148	1408	600	1000	406	210
BS2V 2 MXV 50-1505-WALL	G 3	G 3	825	495	920	148	148	1408	600	1000	406	-
BS2V 2 MXV 50-1506-WALL	G 3	G 3	825	495	920	148	148	1408	600	1000	406	-
BS2V 2 MXV 50-1507-WALL	G 3	G 3	825	495	920	148	148	1408	600	1000	406	-
BS2V 2 MXV 50-1508/A-WALL	G 3	G 3	825	495	920	148	148	1408	600	1000	406	-
BS2V 2 MXV 50-1509-WALL	G 3	G 3	825	495	920	148	148	1408	600	1000	406	-
BS2V 2 MXV 50-1510-WALL	G 3	G 3	825	495	920	148	148	1408	600	1000	406	-
BS2V 2 MXV 50-1512-WALL	G 3	G 3	825	495	920	148	148	1408	600	1000	406	-
BS2V 2 MXV 50-1515-WALL	G 3	G 3	825	495	920	148	148	1408	600	1000	406	-
BS2V 2 MXV 50-1517-WALL	G 3	G 3	825	495	920	148	148	1408	600	1000	406	-
BS2V 2 MXV 50-2003-WALL	G 3	G 3	825	495	920	148	148	1408	600	1000	406	-
BS2V 2 MXV 50-2004-WALL	G 3	G 3	825	495	920	148	148	1408	600	1000	406	-
BS2V 2 MXV 50-2005-WALL	G 3	G 3	825	495	920	148	148	1408	600	1000	406	-
BS2V 2 MXV 50-2006-WALL	G 3	G 3	825	495	920	148	148	1408	600	1000	406	-
BS2V 2 MXV 50-2007-WALL	G 3	G 3	825	495	920	148	148	1408	600	1000	406	-
BS2V 2 MXV 50-2008-WALL	G 3	G 3	825	495	920	148	148	1408	600	1000	406	-
BS2V 2 MXV 50-2009-WALL	G 3	G 3	825	495	920	148	148	1408	600	1000	406	-
BS2V 2 MXV 50-2011-WALL	G 3	G 3	825	495	920	148	148	1408	600	1000	406	-
BS2V 2 MXV 50-2015-WALL	G 3	G 3	825	495	920	148	148	1408	600	1000	406	-

Non-binding dimensions to be checked when ordering

## Dimensions and weights

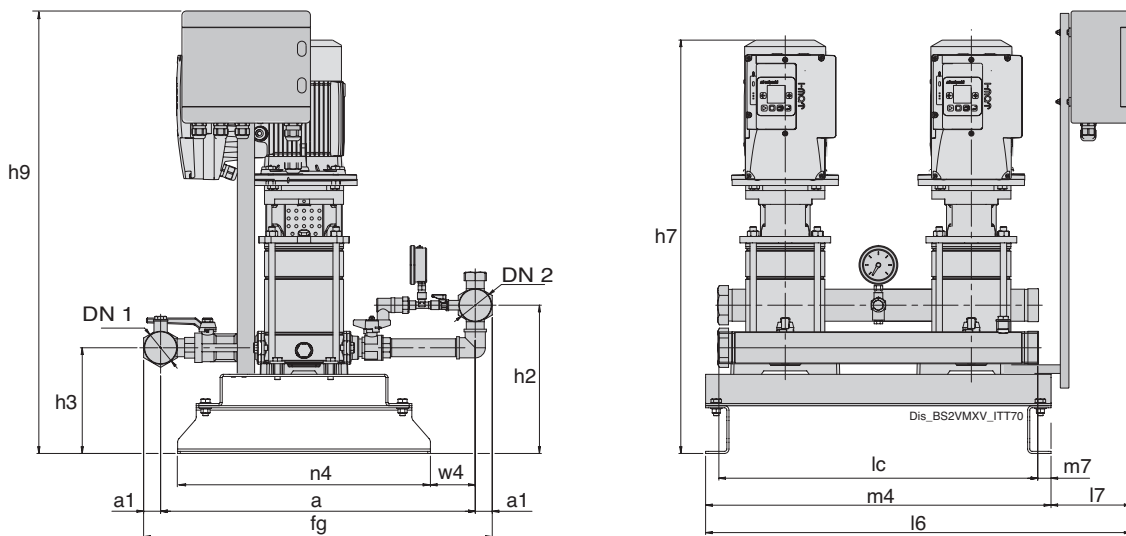

TYPE	Manifolds		mm													Kg Weight
	DN1	DN2	a	a1	fG	h2	h3	h7	h9	l6	l7	lc	m4	n4	w4	
BS2V 2 MXV 25-304 O-ITT	G 1 1/2	G 1 1/2	589	26.5	642	170	94	666	884	825	200	600	625	365	140	-
BS2V 2 MXV 25-305 O-ITT	G 1 1/2	G 1 1/2	589	26.5	642	170	94	690	884	825	200	600	625	365	140	-
BS2V 2 MXV 25-306 O-ITT	G 1 1/2	G 1 1/2	589	26.5	642	170	94	714	884	825	200	600	625	365	140	-
BS2V 2 MXV 25-307 O-ITT	G 1 1/2	G 1 1/2	589	26.5	642	170	94	738	884	825	200	600	625	365	140	100
BS2V 2 MXV 25-308 O-ITT	G 1 1/2	G 1 1/2	589	26.5	642	170	94	762	884	825	200	600	625	365	140	-
BS2V 2 MXV 25-310 O-ITT	G 1 1/2	G 1 1/2	589	26.5	642	170	94	811	884	825	200	600	625	365	140	-
BS2V 2 MXV 25-312 O-ITT	G 1 1/2	G 1 1/2	589	26.5	642	170	94	899	884	825	200	600	625	365	140	-
BS2V 2 MXV 32-504 O-ITT	G 2 1/2	G 2 1/2	642	40	706	186	94	666	884	825	200	600	625	365	168	-
BS2V 2 MXV 32-505 O-ITT	G 2 1/2	G 2 1/2	642	40	706	186	94	690	884	825	200	600	625	365	168	99.2
BS2V 2 MXV 32-506 O-ITT	G 2 1/2	G 2 1/2	642	40	706	186	94	714	884	825	200	600	625	365	168	104.5
BS2V 2 MXV 32-507 O-ITT	G 2 1/2	G 2 1/2	642	40	706	186	94	738	884	825	200	600	625	365	168	105.5
BS2V 2 MXV 32-508 O-ITT	G 2 1/2	G 2 1/2	642	40	706	186	94	802	884	825	200	600	625	365	168	114.5
BS2V 2 MXV 32-510 O-ITT	G 2 1/2	G 2 1/2	642	40	706	186	94	851	884	825	200	600	625	365	168	118.1
BS2V 2 MXV 32-512 O-ITT	G 2 1/2	G 2 1/2	642	40	706	186	94	915	884	825	200	600	625	365	168	135.2
BS2V 2 MXV 40-904 O-ITT	G 2 1/2	G 2 1/2	740	40	820	238	124	711	884	825	200	600	625	365	200	114
BS2V 2 MXV 40-905 O-ITT	G 2 1/2	G 2 1/2	740	40	820	238	124	781	884	825	200	600	625	365	200	123.5
BS2V 2 MXV 40-906 O-ITT	G 2 1/2	G 2 1/2	740	40	820	238	124	811	884	825	200	600	625	365	200	125.6
BS2V 2 MXV 40-907 O-ITT	G 2 1/2	G 2 1/2	740	40	820	238	124	857	884	825	200	600	625	365	200	-
BS2V 2 MXV 40-908 O-ITT	G 2 1/2	G 2 1/2	740	40	820	238	124	887	884	825	200	600	625	365	200	143.6
BS2V 2 MXV 40-910 O-ITT	G 2 1/2	G 2 1/2	740	40	820	238	124	947	884	825	200	600	625	365	200	154.6
BS2V 2 MXV 40-911 O-ITT	G 2 1/2	G 2 1/2	740	40	820	170	94	977	884	825	200	600	625	365	200	-

Non-binding dimensions to be checked when ordering

## Dimensions and weights

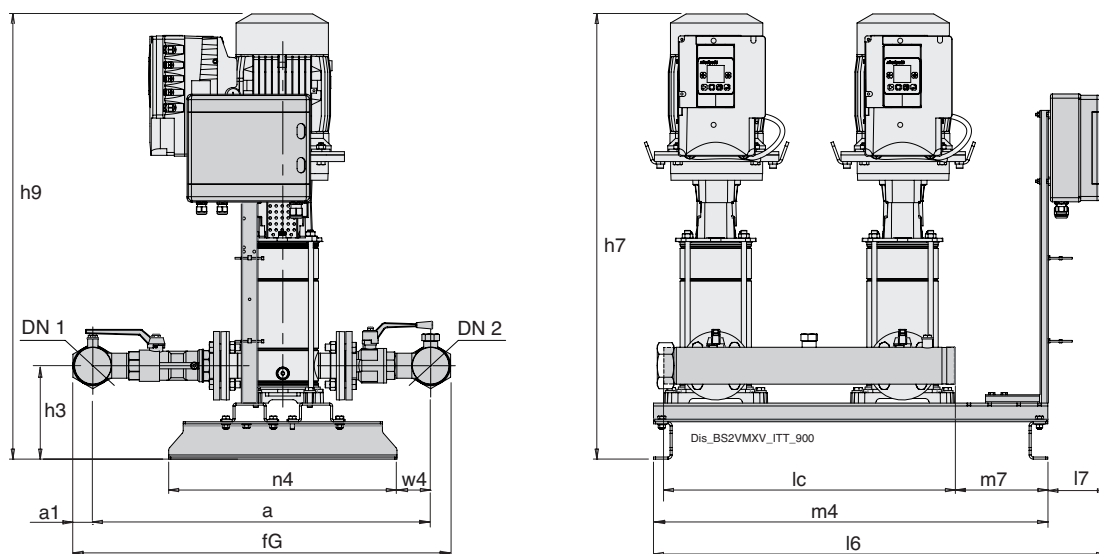

TYPE	Manifolds		mm												Kg Weight
	DN1	DN2	a	a1	fG	h3	h7	h9	l6	l7	lc	m4	n4	w4	
BS2V 2 MXV 50-1503/A-ITT	G 3	G 3	816	48	913	225	934	975	1110	145	700	82	550	82	184
BS2V 2 MXV 50-1504-ITT	G 3	G 3	816	48	913	225	980	975	1110	145	700	82	550	82	187
BS2V 2 MXV 50-1505-ITT	G 3	G 3	816	48	913	225	1028	975	1110	145	700	82	550	82	200
BS2V 2 MXV 50-1506-ITT	G 3	G 3	816	48	913	225	1167	975	1110	145	700	82	550	82	252
BS2V 2 MXV 50-1507-ITT	G 3	G 3	816	48	913	225	1215	1175	1110	145	700	82	550	82	254
BS2V 2 MXV 50-1508/A-ITT	G 3	G 3	816	48	913	225	1263	1175	1110	145	700	82	550	82	260
BS2V 2 MXV 50-1509-ITT	G 3	G 3	816	48	913	225	1311	1175	1110	145	700	82	550	82	289.5
BS2V 2 MXV 50-1510-ITT	G 3	G 3	816	48	913	225	1359	1175	1110	145	700	82	550	82	-
BS2V 2 MXV 50-2003-ITT	G 3	G 3	816	48	913	225	932	975	1142	145	700	82	550	82	-
BS2V 2 MXV 50-2004-ITT	G 3	G 3	816	48	913	225	967	975	1142	145	700	82	550	82	195
BS2V 2 MXV 50-2005-ITT	G 3	G 3	816	48	913	225	1119	975	1142	145	700	82	550	82	248
BS2V 2 MXV 50-2006-ITT	G 3	G 3	816	48	913	225	1167	975	1142	145	700	82	550	82	280
BS2V 2 MXV 50-2007-ITT	G 3	G 3	816	48	913	225	1215	1175	1142	145	700	82	550	82	281.5
BS2V 2 MXV 50-2008-ITT	G 3	G 3	816	48	913	225	1367	1175	1142	145	700	82	550	82	351.5
BS2V 2 MXV 50-2009-ITT	G 3	G 3	816	48	913	225	1415	1175	1142	145	700	82	550	82	-

Non-binding dimensions to be checked when ordering

## Dimensions and weights

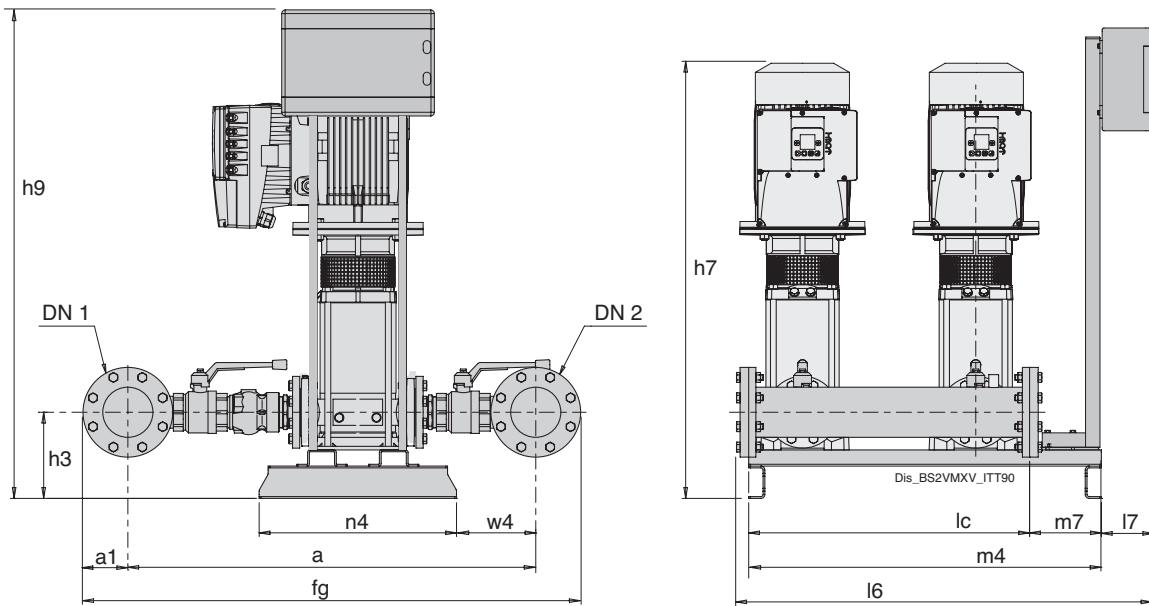

TYPE	Manifolds		mm											Kg Weight	
	DN1	DN2	a	a1	fG	h3	h7	h9	l6	l7	lc	m4	n4		w4
BS2V 2 MXV 65-3202/D-ITT	100	100	1090	110	1310	240	853	975	1114	145	750	950	550	231	279.5
BS2V 2 MXV 65-3203/C-ITT	100	100	1090	110	1310	240	947	975	1114	145	750	950	550	231	320.5
BS2V 2 MXV 65-3204/C-ITT	100	100	1090	110	1310	240	993	975	1204	145	750	950	550	231	355
BS2V 2 MXV 65-3205/D-ITT	100	100	1090	110	1310	240	1189	1175	1204	145	750	950	550	231	462.5
BS2V 2 MXV 65-3206/D-ITT	100	100	1090	110	1310	240	1235	1175	1204	145	750	950	550	231	444
BS2V 2 MXV 65-3207/D-ITT	100	100	1090	110	1310	240	1306	1175	1204	145	750	950	550	231	-
BS2V 2 MXV 80-4802/C-ITT	125	125	1191	125	1441	240	940	975	1080	145	750	950	550	279	-
BS2V 2 MXV 80-4803/C-ITT	125	125	1191	125	1441	240	1001	975	1170	145	750	950	550	279	385
BS2V 2 MXV 80-4804/D-ITT	125	125	1191	125	1441	240	1212	1175	1170	145	750	950	550	279	492.5
BS2V 2 MXV 80-4805/D-ITT	125	125	1191	125	1441	240	1299	1175	1170	145	750	950	550	279	-
BS2V 2 MXV 80-4806/D-ITT	125	125	1191	125	1441	240	1360	1175	1170	145	750	950	550	279	-
BS2V 2 MXV 80-4807/E-ITT	125	125	1191	125	1441	240	1498	1175	1170	145	750	950	550	279	-
BS2V 2 MXV 100-6501/A-ITT	150	150	-	142.5	-	-	1302	-	-	-	950	-	-	-	-
BS2V 2 MXV 100-6502-2R/A-ITT	150	150	-	142.5	-	-	1394	-	-	-	950	-	-	-	-
BS2V 2 MXV 100-6502/A-ITT	150	150	-	142.5	-	-	1534	-	-	-	950	-	-	-	-
BS2V 2 MXV 100-6503-2R/A-ITT	150	150	-	142.5	-	-	1651	-	-	-	950	-	-	-	-
BS2V 2 MXV 100-6503/B-ITT	150	150	-	142.5	-	-	1705	-	-	-	950	-	-	-	782
BS2V 2 MXV 100-6504-2R/B-ITT	150	150	-	142.5	-	-	1797	-	-	-	950	-	-	-	-
BS2V 2 MXV 100-6504/A-ITT	150	150	-	142.5	-	-	1797	-	-	-	950	-	-	-	-
BS2V 2 MXV 100-9001/A-ITT	200	200	1543	170	1883	370	1306	-	-	-	950	1300	1050	260	-
BS2V 2 MXV 100-9002-2R/A-ITT	200	200	1543	170	1883	370	1538	-	-	-	950	1300	1050	260	770
BS2V 2 MXV 100-9002/A-ITT	200	200	1543	170	1883	370	1563	-	-	-	950	1300	1050	260	879
BS2V 2 MXV 100-9003-2R/B-ITT	200	200	1543	170	1883	370	1709	-	-	-	950	1300	1050	260	-
BS2V 2 MXV 100-9003/A-ITT	200	200	1543	170	1883	370	1709	-	-	-	950	1300	1050	260	-

Non-binding dimensions to be checked when ordering

## Dimensions and weights

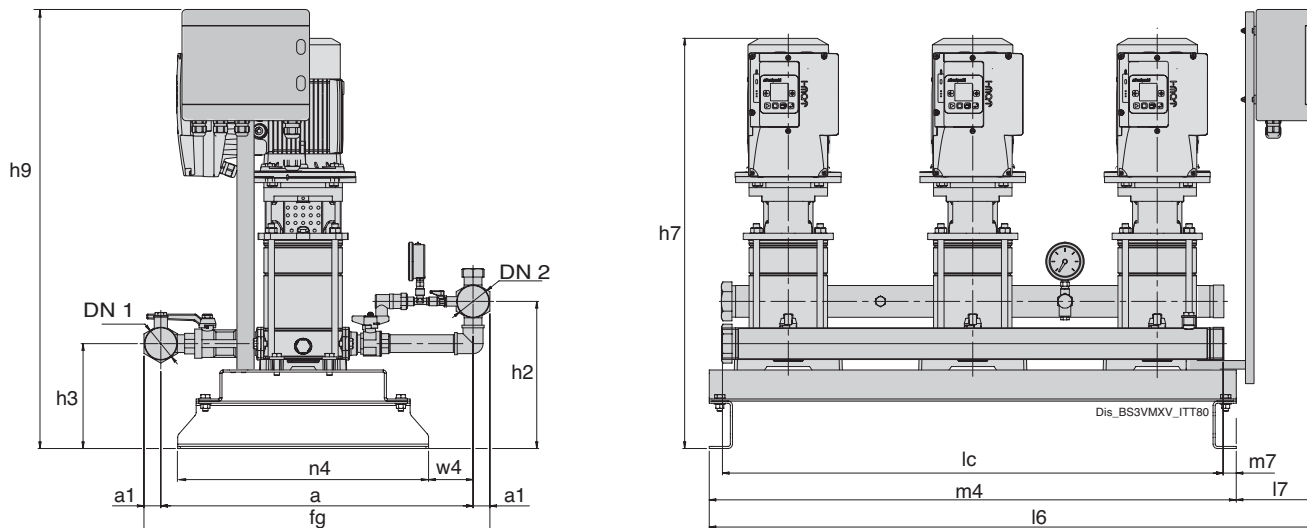

TYPE	Manifolds		mm													Kg Weight
	DN1	DN2	a	a1	fg	h2	h3	h7	h9	l6	l7	lc	m4	n4	w4	
BS3V 3 MXV 25-304 O-ITT	G 2	G 2	593	32	657	279	199	771	989	1200	200	950	1000	476	84	-
BS3V 3 MXV 25-305 O-ITT	G 2	G 2	593	32	657	279	199	795	989	1200	200	950	1000	476	84	-
BS3V 3 MXV 25-306 O-ITT	G 2	G 2	593	32	657	279	199	819	989	1200	200	950	1000	476	84	-
BS3V 3 MXV 25-307 O-ITT	G 2	G 2	593	32	657	279	199	843	989	1200	200	950	1000	476	84	-
BS3V 3 MXV 25-308 O-ITT	G 2	G 2	593	32	657	279	199	867	989	1200	200	950	1000	476	84	-
BS3V 3 MXV 25-310 O-ITT	G 2	G 2	593	32	657	279	199	916	989	1200	200	950	1000	476	84	-
BS3V 3 MXV 25-312 O-ITT	G 2	G 2	593	32	657	279	199	1004	989	1200	200	950	1000	476	84	-
BS3V 3 MXV 32-504 O-ITT	G 2 1/2	G 2 1/2	650	40	730	299	199	771	989	1200	200	950	1000	476	113	-
BS3V 3 MXV 32-505 O-ITT	G 2 1/2	G 2 1/2	650	40	730	299	199	795	989	1200	200	950	1000	476	113	156.5
BS3V 3 MXV 32-506 O-ITT	G 2 1/2	G 2 1/2	650	40	730	299	199	819	989	1200	200	950	1000	476	113	162.5
BS3V 3 MXV 32-507 O-ITT	G 2 1/2	G 2 1/2	650	40	730	299	199	843	989	1200	200	950	1000	476	113	-
BS3V 3 MXV 32-508 O-ITT	G 2 1/2	G 2 1/2	650	40	730	299	199	907	989	1200	200	950	1000	476	113	180
BS3V 3 MXV 32-510 O-ITT	G 2 1/2	G 2 1/2	650	40	730	299	199	956	989	1200	200	950	1000	476	113	184.5
BS3V 3 MXV 32-512 O-ITT	G 2 1/2	G 2 1/2	650	40	730	299	199	1020	989	1200	200	950	1000	476	113	-
BS3V 3 MXV 40-904 O-ITT	G 3	G 3	746	48	842	349	229	816	989	1200	200	950	1000	476	145	-
BS3V 3 MXV 40-905 O-ITT	G 3	G 3	746	48	842	349	229	886	989	1200	200	950	1000	476	145	195
BS3V 3 MXV 40-906 O-ITT	G 3	G 3	746	48	842	349	229	916	989	1200	200	950	1000	476	145	-
BS3V 3 MXV 40-907 O-ITT	G 3	G 3	746	48	842	349	229	962	989	1200	200	950	1000	476	145	-
BS3V 3 MXV 40-908 O-ITT	G 3	G 3	746	48	842	349	229	992	989	1200	200	950	1000	476	145	223.5
BS3V 3 MXV 40-910 O-ITT	G 3	G 3	746	48	842	349	229	1052	989	1200	200	950	1000	476	145	242
BS3V 3 MXV 40-911 O-ITT	G 3	G 3	746	48	842	349	229	1082	989	1200	200	950	1000	476	145	-

Non-binding dimensions to be checked when ordering



## Dimensions and weights

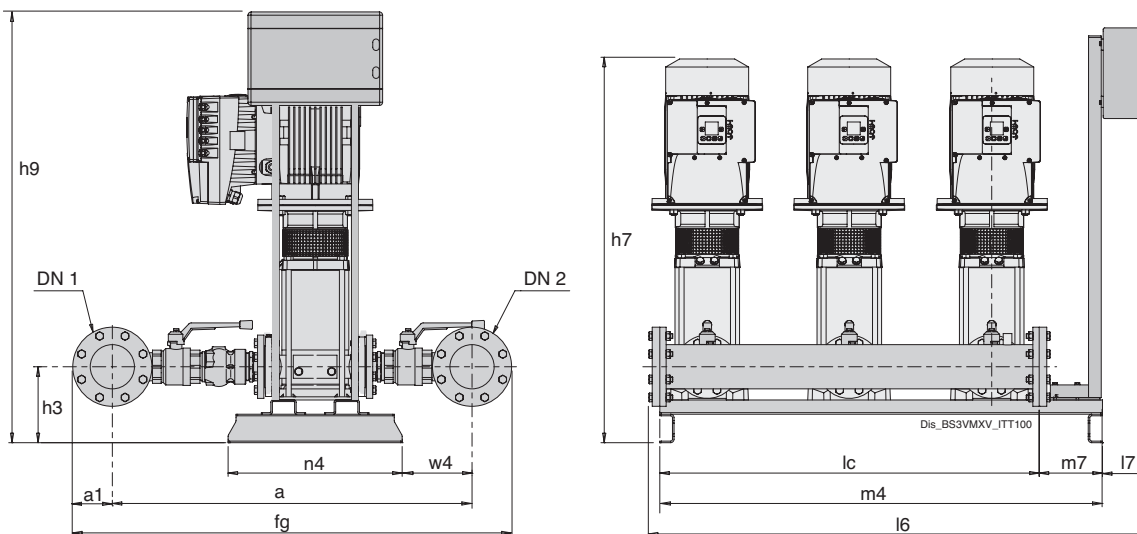

TYPE	Manifolds		mm												Kg Weight
	DN1	DN2	a	a1	fG	h3	h7	h9	l6	l7	lc	m4	n4	w4	
BS3V 3 MXV 50-1503/A-ITT	100	100	880	110	1100	296	1005	1040	1577	145	1200	1400	550	94	-
BS3V 3 MXV 50-1504-ITT	100	100	880	110	1100	296	1051	1040	1577	145	1200	1400	550	94	359
BS3V 3 MXV 50-1505-ITT	100	100	880	110	1100	296	1099	1040	1577	145	1200	1400	550	94	178.5
BS3V 3 MXV 50-1506-ITT	100	100	880	110	1100	296	1239	1240	1577	145	1200	1400	550	94	458
BS3V 3 MXV 50-1507-ITT	100	100	880	110	1100	296	1287	1240	1577	145	1200	1400	550	94	453.5
BS3V 3 MXV 50-1508/A-ITT	100	100	880	110	1100	296	1335	1240	1577	145	1200	1400	550	94	502
BS3V 3 MXV 50-1509-ITT	100	100	880	110	1100	296	1382	1240	1577	145	1200	1400	550	94	-
BS3V 3 MXV 50-1510-ITT	100	100	880	110	1100	296	1430	1240	1577	145	1200	1400	550	94	-
BS3V 3 MXV 50-2003-ITT	100	100	880	110	1100	296	1003	1040	1577	145	1200	1400	550	94	349
BS3V 3 MXV 50-2004-ITT	100	100	880	110	1100	296	1038	1040	1577	145	1200	1400	550	94	178.5
BS3V 3 MXV 50-2005-ITT	100	100	880	110	1100	296	1190	-	1577	145	1200	1400	550	94	-
BS3V 3 MXV 50-2006-ITT	100	100	880	110	1100	296	1238	1240	1577	145	1200	1400	550	94	490
BS3V 3 MXV 50-2007-ITT	100	100	880	110	1100	296	1286	1240	1577	145	1200	1400	550	94	496
BS3V 3 MXV 50-2008-ITT	100	100	880	110	1100	296	1438	-	1577	145	1200	1400	550	94	178.5
BS3V 3 MXV 50-2009-ITT	100	100	880	110	1100	296	1486	-	1577	145	1200	1400	550	94	596
BS3V 3 MXV 65-3202/D-ITT	125	125	1156	125	1406	291	903	1020	1579	145	1200	1400	550	284	456
BS3V 3 MXV 65-3203/C-ITT	125	125	1156	125	1406	291	997	1020	1579	145	1200	1400	550	284	515
BS3V 3 MXV 65-3204/C-ITT	125	125	1156	125	1406	291	1043	1020	1579	145	1200	1400	550	284	559
BS3V 3 MXV 65-3205/D-ITT	125	125	1156	125	1406	291	1239	1220	1579	145	1200	1400	550	284	-
BS3V 3 MXV 65-3206/D-ITT	125	125	1156	125	1406	291	1285	1220	1579	145	1200	1400	550	284	-
BS3V 3 MXV 65-3207/D-ITT	125	125	1156	125	1406	291	1356	1388	1704	270	1200	1400	550	284	843
BS3V 3 MXV 80-4802/C-ITT	125	125	1240	125	1525	291	990	1020	1582	145	1200	1400	550	313	-
BS3V 3 MXV 80-4803/C-ITT	125	125	1240	125	1525	291	1051	1020	1582	145	1200	1400	550	313	604.5
BS3V 3 MXV 80-4804/D-ITT	125	125	1240	125	1525	291	1262	1220	1582	145	1200	1400	550	313	761
BS3V 3 MXV 80-4805/D-ITT	125	125	1240	125	1525	291	1349	1388	1707	270	1200	1400	550	313	234
BS3V 3 MXV 80-4806/D-ITT	125	125	1240	125	1525	291	1410	1388	1707	270	1200	1400	550	313	890
BS3V 3 MXV 80-4807/E-ITT	125	125	1240	125	1525	291	1548	1388	1707	270	1200	1400	550	313	-
BS3V 3 MXV 100-6501/A-ITT	150	150	1318	142.5	1658	386	1322	-	-	-	1500	1650	900	65	-
BS3V 3 MXV 100-6502-2R/A-ITT	150	150	1318	142.5	1658	386	1414	-	-	-	1500	1650	900	65	-
BS3V 3 MXV 100-6502/A-ITT	150	150	1318	142.5	1658	386	1554	-	-	-	1500	1650	900	65	-
BS3V 3 MXV 100-6503-2R/A-ITT	150	150	1318	142.5	1658	386	1671	-	-	-	1500	1650	900	65	-
BS3V 3 MXV 100-6503/B-ITT	150	150	1318	142.5	1658	386	1725	-	-	-	1500	1650	900	65	-
BS3V 3 MXV 100-6504-2R/B-ITT	150	150	1318	142.5	1658	386	1817	-	-	-	1500	1650	900	65	-
BS3V 3 MXV 100-6504/A-ITT	150	150	1318	142.5	1658	386	1817	-	-	-	1500	1650	900	65	1240
BS3V 3 MXV 100-9001/A-ITT	200	200	1561	170	1901	390	1326	-	-	-	1500	1850	1050	280	-
BS3V 3 MXV 100-9002-2R/A-ITT	200	200	1561	170	1901	390	1558	-	-	-	1500	1850	1050	280	-
BS3V 3 MXV 100-9002/A-ITT	200	200	1561	170	1901	390	1583	-	-	-	1500	1850	1050	280	-
BS3V 3 MXV 100-9003-2R/B-ITT	200	200	1561	170	1901	390	1729	-	-	-	1500	1850	1050	280	1360
BS3V 3 MXV 100-9003/A-ITT	200	200	1561	170	1901	390	1729	-	-	-	1500	1850	1050	280	-

Non-binding dimensions to be checked when ordering