



CSS PUMP RANGE

VERTICAL, **SEAL-LESS**, THERMOPLASTIC, CENTRIFUGAL PUMPS



**MANUFACTURED
IN THE UK**

-  CAPACITY < 65 M³/HR
-  HEAD < 40 Metres
-  COLUMN LENGTH < 750MM
-  RUN DRY CAPABILITY
-  MINIMAL MAINTENANCE
-  FLEXIBLE TO YOUR SPEC
-  TOTAL CORROSION RESISTANCE

Part of the
VERTICAL PLASTIC
Pump Range



BUILT TO YOUR REQUIREMENTS

The vertical range are proven to stand the test of time offering solid performance constantly throughout the pumps lifetime. And because of their run dry capability, minimise both operational costs and maintenance costs whilst keeping your process running efficiently and reliably.

To ensure that we supply you with a pump that will last in the harshest of environments, pumps are available in a variety of materials including polypropylene, PVC, PVDF and 316 stainless steel. Every plastic vertical pump in our range is designed and manufactured in the UK so we can tailor the pump to your exact requirements – whether that be a particular column length, mounting plate shape or outlet position. Usually with very little difference in price or lead time compared to a standard pump.

HEAVY DUTY

The CSS range of vertical plastic pumps have been perfected over 40 years to combat harsh and corrosive chemicals making the CSS range ideal for applications such as sump emptying, recirculation, effluent treatment and fume scrubbers.

Built with a cantilever shaft design, CSS pumps have no immersed bearings which allows the pump to run-dry indefinitely without damage. Bearings aren't required at the bottom of the pump due to the oversized shaft which adds stability to prevent shaft whipping.

The CSS range is available in polypropylene, PVC, PVDF or 316 stainless steel for the ultimate corrosion resistance to harsh and acidic applications. O-rings are available in Viton, EPDM or Kalrez.

The support column is fabricated and incorporates a double skinned, heavy duty tube arrangement making the CSS range of pumps exceptionally rugged and robust.



**2 YEAR
WARRANTY**



**ATEX ZONE 1/2
CERTIFIED**



**MINIMAL
MAINTENANCE**



**PATENTED RUN
DRY DESIGN**



**CORROSION
RESISTANCE**



**NO OBSOLETE
PARTS POLICY**



**FLEXIBLE TO
DESIGN SPEC**



**MANUFACTURED
IN THE UK**

CSS PUMP RANGE

VERTICAL, **SEAL-LESS**, THERMOPLASTIC, CENTRIFUGAL PUMPS

∞ PUMP RANGE CURVES

Pump curves for the CSS range of vertical pumps.

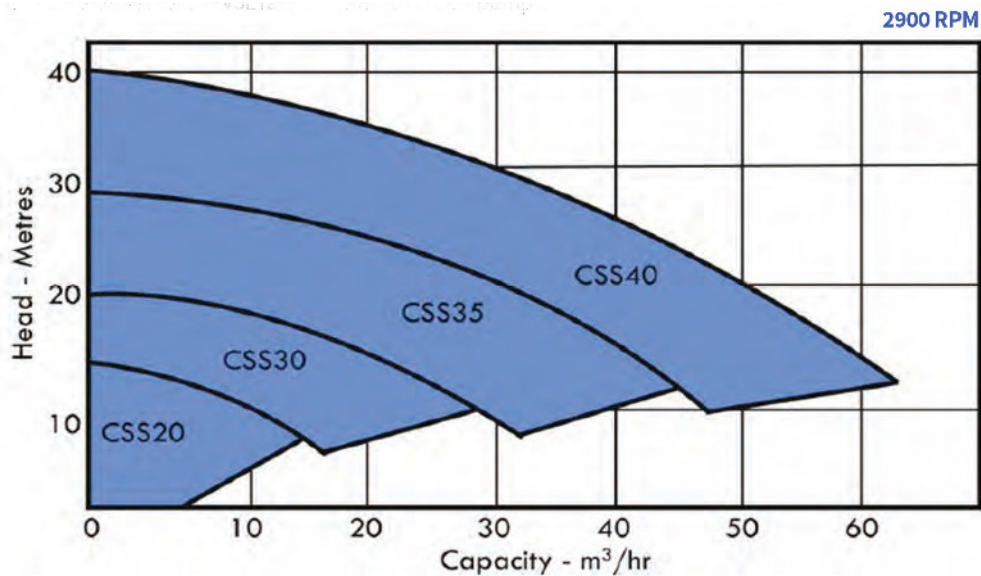

∞ TECHNICAL SPECIFICATION

MODEL	SUCTION (inches)	DIS-CHARGE (inches)	SPEED (rpm)	RATED CAPACITY (m³/hr)	RATED HEAD (m)	MAX CAPACITY (m³/hr)	MAX HEAD (m)	MOTOR OUTPUT (kW)
CSS 20	1.5	1.25	2900	9	9	16	13	1.5
CSS 30	2	1.5	2900	15	16	28	18	3
CSS 35	2.5	2	2900	30	22	50	28	5.5
CSS 40	2.5	2	2900	30	34	60	40	11

∞ NO OBSOLETE PARTS POLICY

The entire range of vertical plastic pumps come with 24 months warranty as standard (longer warranties available on request), as an assurance to your business that our pumps are quality built to stand the test of time. We take great pride in taking replacement or spares orders for pumps that were built and installed over 30 years ago.



All of our pumps come with our No obsolete parts policy, meaning if you have a Crest Pump for 40 years, we will still be able to provide you with the necessary parts or an exact replacement to minimise disruption to your process.

Our vertical pumps have been utilised by some of the largest companies in the world, including Unilever, BASF Chemicals, GlaxoSmithKline, Conocophillips, Centrica and General Electric.

CSS PUMP RANGE

VERTICAL, **SEAL-LESS**, THERMOPLASTIC, CENTRIFUGAL PUMPS

∞ RANGE DIMENSIONS

For specific 3D CAD drawings or specific pump dimensions, please contact us at info@crestpumps.co.uk or telephone +44 (0)1425 627700.

NOTE:

1. The total length and weight of the pump will differ depending on the brand of the motor.
2. All dimensions are in mm.
3. Assembly tolerances are +/- 3mm.

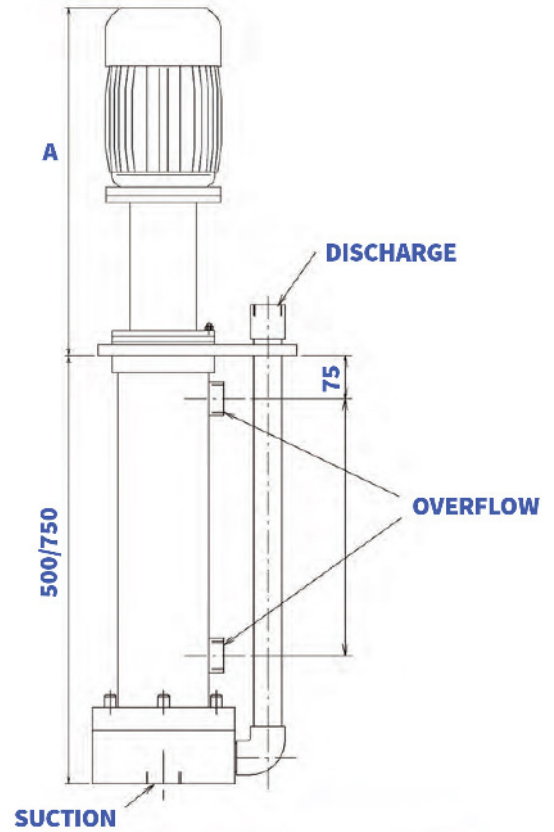
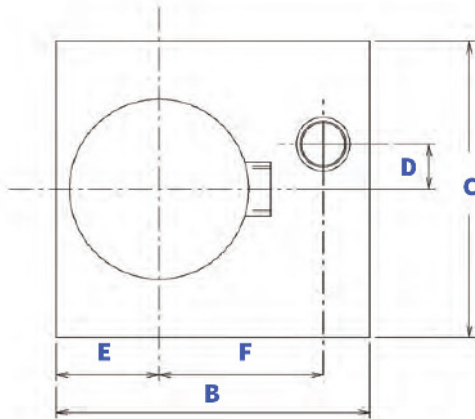

MODEL	A	B	C	D	E	F
CSS 20	*	330	330	45	54	154
CSS 30	*	330	330	50	50	165
CSS 35	*	480	480	63	113	202
CSS 40	*	480	480	72	108	207

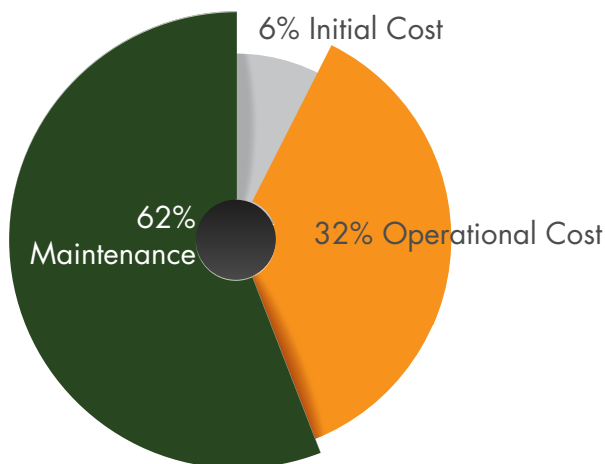

∞ INFORMATION

LONG TERM RELIABILITY, LOWER LIFECYCLE COSTS

Crest Pumps Group has one aim...
To ensure your process remains efficient and reliable through the pump's lifespan.

We aim to maximise our range reliability and ensure long-term maintainable performance to help keep the total cost of the pump ownership lower than our competitors.

In a typical process pump lifespan of 20 years, 94% of the total cost are a direct result from maintenance, operating costs and installation.

By ensuring reliability of our range we keep maintenance cost down.

www.crestpumps.co.uk

CSS PUMP RANGE



VERTICAL, **SEAL-LESS**, THERMOPLASTIC, CENTRIFUGAL PUMPS

∞ CASE STUDY - TRADEBE

“Custom built CSS pump for UK hazardous waste treatment plant”

Tradebe own and operate one of the two commercial High Temperature Incinerators for industrial waste in the UK (Fawley).

High Temperature Incineration provides the highest level of secure and reliable disposal for hazardous organic wastes. The plant at Fawley complies with all European legal and environmental requirements and is a cost effective means of securely disposing of customers combustible waste. Running at high temperatures means Tradebe can guarantee the destruction of the hazardous or sensitive nature of the waste converting it into ashes and filter cakes with a typical volume reduction factor of 80%.

Crest Pumps provided a CSS35 (as pictured to the right) specially built with the motor on a belt drive to create the smallest possible footprint in order for it to be installed in a difficult tight space underneath a road.

The CSS35 is capable of pumping wastewater combined with hydrochloric acid at a duty of 30m³/hr at 20m head and has proven to be the perfect pump for the job for Tradebe.



∞ CREST VERTICAL PUMPS - UTILISED BY



∞ APPLICATIONS

CHEMICAL
Chemical applications include chemical transfer, dosing, re-circulation, filtration, fume scrubbing and tanker off-loading.

PETROCHEMICAL
Previous petrochemical installations include high temperature, high pressure, highly viscous applications as well as chemical injection, re-circulation, off-loading and solid handling.

WATER TREATMENT
Providing reliable process pumps to the UK's largest wastewater treatment providers, for chemical transfer, desalination, reverse osmosis, water treatment and tanker unloading.

PHARMACEUTICAL
Pharmaceutical companies have relied on Crest Pumps to provide pumps for ATEX requirements, chemical injection, CIP pumping, solid handling, high viscous medias and highly toxic applications.

BIOFUELS
Fully ATEX certified process pumps for transfer of liquids in explosive atmospheres, solids handling, tanker unloading, recirculation and transfer.

ENERGY GENERATION
Pumps supplied for various energy generation applications, including wind turbine, solar, and Vanadium redox flow batteries.

MARINE
Centrifugal pumps supplied for various below deck applications including ballast water treatment, electrolysis, desalination and sea water cooling systems.