

AVF - C PUMP RANGE

SUPERIOR EFFICIENCY **CANNED MOTOR PUMPS**



- ∞ CAPACITY 51 M³/Hr
- ∞ HEAD 37M
- ∞ POLYPROPYLENE / ETFE CONSTRUCTION
- ∞ CANNED MOTOR, SEAL-LESS
- ∞ TOTAL CORROSION RESISTANCE
- ∞ REDUCED LIFE CYCLE COST
- ∞ MINIMUM EFFICIENCY INDEX > 0.7

Part of the
MAGNETIC DRIVE
Pump Range



∞ AVF-C OVERVIEW

The AVF-C is built to save you energy - with the highest motor efficiency (IE5 & GB1 equivalent), highest pump efficiency (Minimum Efficiency Index, MEI >0.7), and variable frequency drive - meaning the smallest carbon emissions chemical pump you will ever own.

Canned motor pumps integrate the design of the electric motor and magnetic drive pumps into one. The stator of the motor directly drives the inner magnet of the pump, eliminating the motor rotor and the drive magnet. Like the magnetic drive pump, the magnetic flux between the stator and the inner magnet passes through the containment shell (can), allowing the pump to be hermetically sealed for leak-free operation.

Because the AVF-C range uses a permanent magnet rotor and there is no induced current compared to an induction motor, efficiency is increased by up to 20% and power consumption reduced by 50% or more.

∞ AVF-C TESTIMONIALS

" A game-changer for our team! The AVF-C pump's compact design and lightweight build have been invaluable to our team. Its portability and ease of handling have simplified our workflow, allowing for seamless integration into various applications. Moreover, we've seen a drastic reduction in maintenance issues, its low maintenance requirements make it a hassle-free choice for our operations, freeing up our teams to focus on what they do best."

"Energy Efficiency like never before! Intel's commitment to innovation extends well beyond processors. Our focus on creating the world's most efficient and sustainable data center solutions. AVF-C series pumps redefine efficiency benchmarks, seamlessly integrating with Intel Open IP immersion cooling system. This collaboration represents a paradigm shift, actively pushing efficiency boundaries and yielding an improved Power Usage Effectiveness (PUE). Proven in our serving cooling systems, these pumps enhance performance while significantly reducing energy consumption. This underscores our dedication to technological excellence and environmental sustainability."



**2 YEARS
WARRANTY**



**ATEX ZONE
1/2 CERTIFIED**



**ENERGY
SAVING**



**CORROSION
RESISTANCE**



**50% ENERGY
SAVING**



IP66

AVF - C PUMP RANGE

SUPERIOR EFFICIENCY **CANNED MOTOR PUMPS**

PUMP RANGE CURVES

Pump curves for the polypropylene AVF - C canned Magnetic Drive pump ranges 221, 441, 553/543, 555/545 and 655.

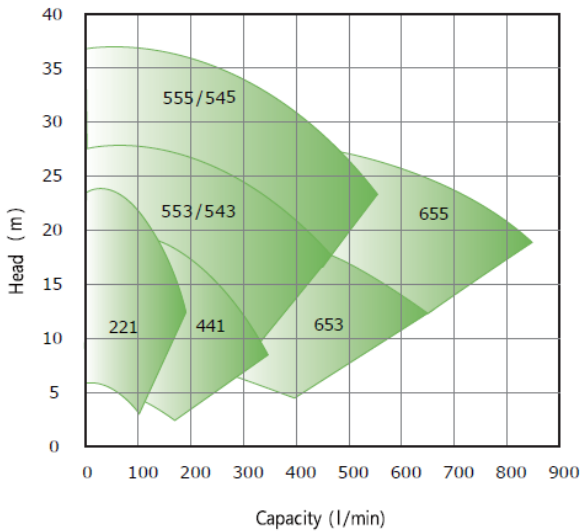

INFORMATION

Everything's Reduced!

Because the AVF range is a fan less design, both heat and noise are significantly reduced compared to traditional mag drive pumps.

And because of the canned motor principle, they are smaller and lighter weight, taking up less floor space and easier to manouvre for maintenance.

TECHNICAL SPECIFICATION

		AVF-C221	AVF-C441	AVF-C543 AVF-C553	AVF-C545 AVF-C555	AVF-C653	AVF-C655
Capacity Range (L/min)		10 - 180	20 - 350	40 - 450	60 - 650	60 - 550	80 - 850
Head Range (m)		6 - 23	5 - 21	8 - 31	8 - 37	4 - 22	7 - 30
Max Motor Output (kW)		1.1	1.1	2.2	4	2.2	4
Rated Current	220V	3.8	3.8	7.3	13	7.3	13
	380V	2.2	2.2	4.2	7.5	4.2	7.5
Speed Range (rpm)		1500 - 3000					
Protection Grade		IP66					



AVF-C PUMP RANGE

SUPERIOR EFFICIENCY **CANNED MOTOR PUMPS**

∞ RANGE DIMENSIONS

For specific 3D CAD drawings or specific pump dimensions, please contact us at info@crestpumps.co.uk or telephone +44 (0)1425 627700.

NOTE:

1. The total length and weight of the pump will differ depending on the brand of the motor.
2. All dimensions are in mm.
3. Assembly tolerances are +/- 3mm.

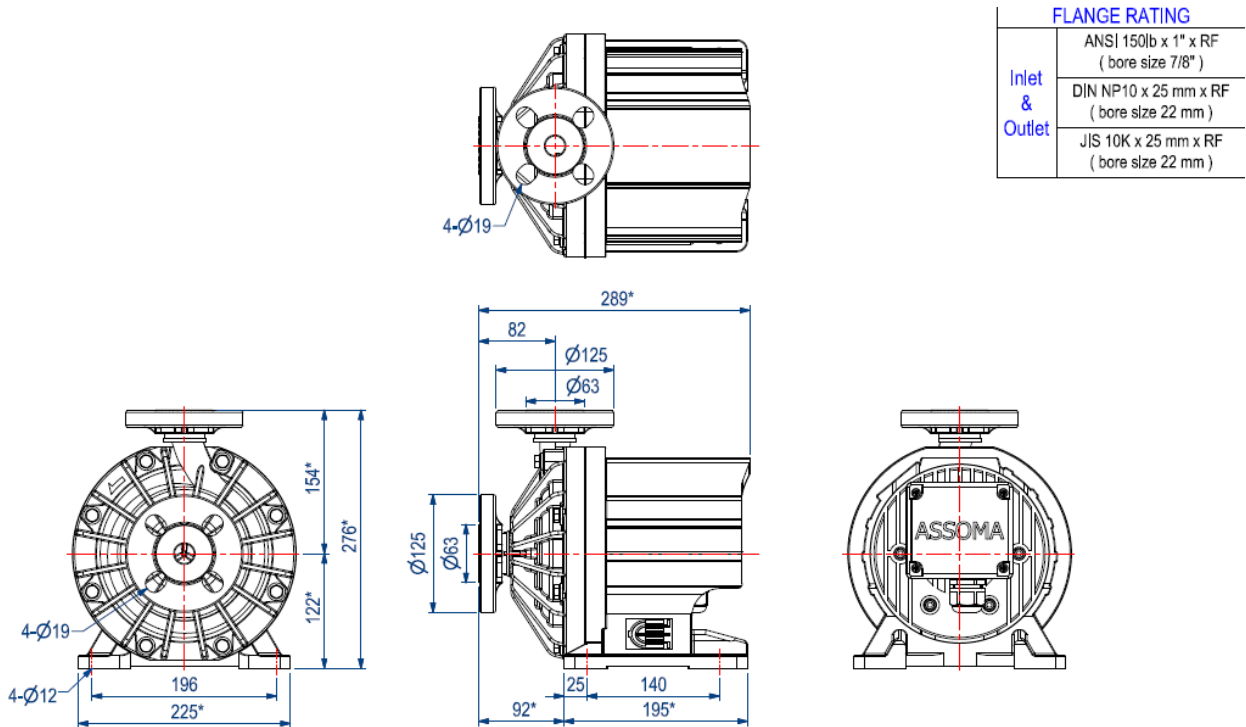

MODEL	DIMENSIONS (mm)													BORE (mm)		FLANGE	
	A	B	B1	E	G	H	H1	H2	L	L1	L2	L3	N	INLET	OUT-LET	INLET	OUT-LET
AVF-C 221	90	225	196	65	95	255	140	115	270	180	25	130	12	21	21	25A	25A
AVF-C 441	106	225	196	72	111	258	143	115	286	180	25	130	12	21	21	40A	40A
AVF-C 543	91	250	210	80	99	313	161	152	329	230	25	180	14	50	40	50A	40A
AVF-C 545																	50A
AVF-C 553																	
AVF-C 555																	
AVF-C 655	92				105	322	170		335					65	50	65A	

AVF - C PUMP RANGE

SUPERIOR EFFICIENCY **CANNED MOTOR PUMPS**

EXPLODED VIEW



A Maintenance-Free Pump Casing - The flanges are socket welded to the pump casing eliminating the need for O-rings, thus requiring zero maintenance. The flanges are also adjustable in order to easily align with mating flanges for a secure and leak-free seal.

B Patented Buffer System - In order to increase the pumps life, the unique buffer system design absorbs any shock generated during abnormal pump operation such as cavitation.

C High-Efficiency Impeller - The closed impeller is precision designed to streamline flow dynamics, minimising hydraulic loss and maximising pump efficiency.

D Increased MTBS - The strengthened gasket seal is specially designed for extended leak-free service. This allows for a much longer Mean Time Between Servicing.

E Rigid Shaft Support - To improve operational reliability and an increased service life, the stationary shaft is supported on both ends. It is tightly fitted in the containment shell and supported by the strong metallic frame of the motor.

F Plastic Containment Shell - The AVF-C is constructed using a seal-less canned design, with the motor's stator providing the direct drive to the pump's rotor. This eliminates the need for a coupling interface, thus greatly reducing the axial dimension and weight of the

G High Efficiency Motor - As a permanent magnet synchronous motor, these currently exceed IE4 and future IE5 efficiency standards. Being fan-less and smaller, they generate little heat or noise, whilst taking up less space.

H Corrosion Resistant Outer Casing - Constructed from Engineering plastics, the entire pump is IP66 rated, providing full protection for the motor against accidental chemical drips/corrosive environments. This also acts as a secondary containment shell in the event of catastrophic pump failure.

I Inverter Controlled - Running the pump with an inverter means you only use the energy required for the process, and when running at lower speeds, it will extend the service life of wear parts.

AVF - C PUMP RANGE

SUPERIOR EFFICIENCY **CANNED MOTOR PUMPS**

PARTS LIST AND MATERIAL CONSTRUCTION

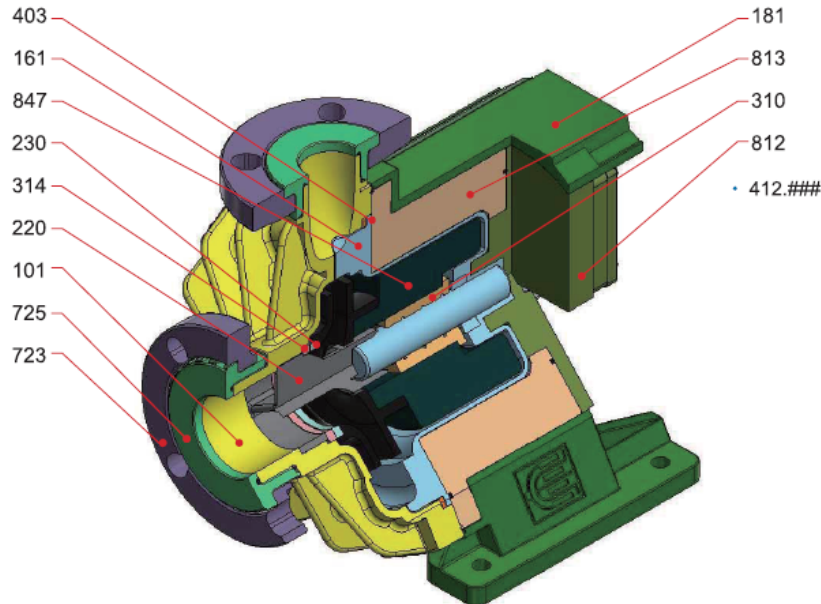

MATERIAL CODE	PART	AVAILABLE MATERIAL
101_a	PUMP CASING ASSEMBLY	
101	PUMP CASING	PP + CF / PP + GF / ETFE + CF
723	FLANGE *	PP + GF
725	FLANGE ADAPTER	PP + GF / ETFE + CF
412.###	O-RING **	EPDM / FKM
161	REAR CASING ASSEMBLY	
	REAR CASING	PP + CF / PP + GF / ETFE + CF
	SHAFT	995 Al ₂ O ₃ / SSiC
	REAR THRUST RING	995 Al ₂ O ₃ / SSiC
181	BRACKET	PP + GF
220	FRONT SUPPORT, SHAFT	ETFE + CF
230	IMPELLER WEAR RING ASSEMBLY	
	IMPELLER	PP + CF / PP + GF / ETFE + CF
	FRONT WEAR RING	CARBON / SSiC / PTFE + CF
310	BEARING	995 Al ₂ O ₃ / CARBON / SSiC / PTFE + CF
314	FRONT THRUST RING	995 Al ₂ O ₃ / SSiC
403	PACKING **	EPDM / FKM
812	REAR FRAME	ALUMINUM
813	STATOR ASSEMBLY	ALUMINUM
847	MAGNET CAPSULE	PP + ETFE
412.###	O RING **	EPDM / FKM

* The flange is not a wetted part, we offer PP + GF as standard materials. Contact us if you have other material needs.

** Alternative O-ring / Packing materials are available for critical applications. Please contact us for further information.