

PSDrive®

**Next generation of electric pump
on-board inverter**



 **Trebles™**
Fluid Motion Specialists

 **varisco®**
solid pumping solutions

Varisco PSDrive can be installed directly on the motor in place of the Varisco pumps terminal board cover.

Next generation of electric pump on-board inverter

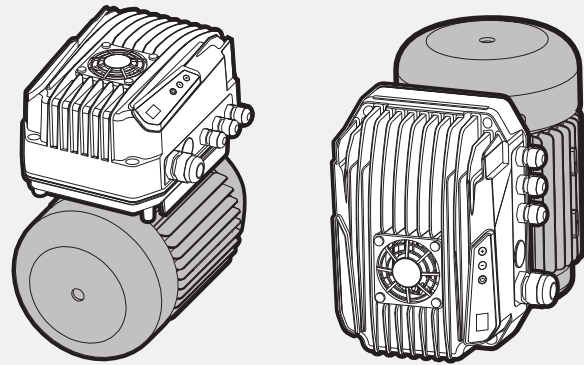

EASY INSTALLATION AND START-UP



PROTECTED AGAINST WATER AND DUST



POSSIBLE REMOTE CONTROL

IT ENSURES:

- > Energy saving due to motor rotation speed control
- > Soft start and soft stop
- > Extended operating life of the pump and protection against overloads
- > Installation on humid and dusty environments made possible by IP66 (NEMA 4X) protection degree
- > Simplified installation on motor or wall
- > Easy and fast commissioning thanks to initial configuration wizard
- > High thermal and mechanical performance thanks to fully aluminium container and independent ventilation

ADVANTAGES

- > Flexibility guaranteed by using the same Varisco pump model in different head conditions (smaller amounts of pumps and spare parts on stock, versatility in case of small system modifications or required performances)
- > Ideal for adjustments on the field without using valves or by-pass systems (considerable energy savings)
- > Possibility to set operating parameters according to signals coming from external transmitters like level, pressure and flow rate

MULTI-PUMP OPERATION

- > Up to 8 units
- > Alternance for uniform pump wearing
- > Master or slave replacement in case of failure to ensure continuity of operation

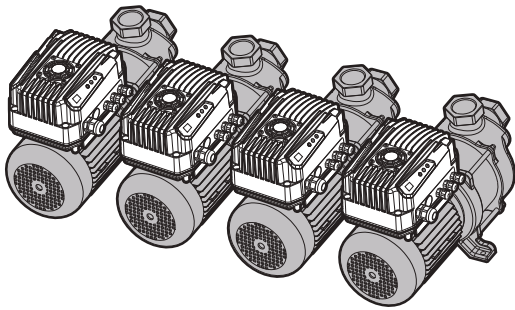

OLED Display

- > Graphic OLED display with extended range of operating temperature and wide viewing angle
- > LED indication of operating conditions (stand-by, run and alarm)
- > Easy direct reading of main parameters and alarms, such as:

[Hz]	Frequency at which the inverter is supplying the motor
[VAC]	Inverter power supply voltage
[A]	Current absorbed by the motor
[cos ϕ]	Motor power factor
[kW]	Estimate of the active electrical power absorbed by the motor.
[INV]	Address of the device when the COMBO function is active.
AXX	Alarm XX
WXX	Warning XX



POSSIBLE CONTROL MODES BY MEANS OF THE SENSORS:

- > Constant pressure control
- > Constant or proportional differential pressure control
- > Constant temperature control
- > Constant differential temperature control. Constant flow control
- > Constant flow control
- > External frequency control (trimmer) or 1 or 2 preset frequencies control

SENSORS CONNECTION

The unit has four analogue inputs to connect pressure, temperature, flow rate sensors, two in 4-20 mA current loop and two in 0-10 Vdc voltage.

The sensors are not included in the supply.

BUILT-IN PROTECTIONS AGAINST:

- > Overvoltage and undervoltage
- > Overcurrent and no load
- > Dry running
- > Overtemperature



Excellent user experience thanks to Varisco PSDrive App

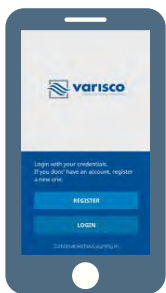

Thanks to the Varisco PSDrive App, it's possible to communicate with all PSDrive Bluetooth® SMART devices in order to:

- > Monitor multiple operating parameters simultaneously on the wide, high definition, coloured screen of your smartphone or tablet
- > Get statistics of energy consumption and check alarms history
- > Make programs, save them in the archive, copy them to other devices and share them among multiple users
- > Perform reports with the possibility to insert notes, images and email them or keep them into the digital archive.
- > Possibility to remotely control the PSDrive by means of Wi-Fi network or GSM, a PSDrive device, using a smartphone in the vicinity as a modem

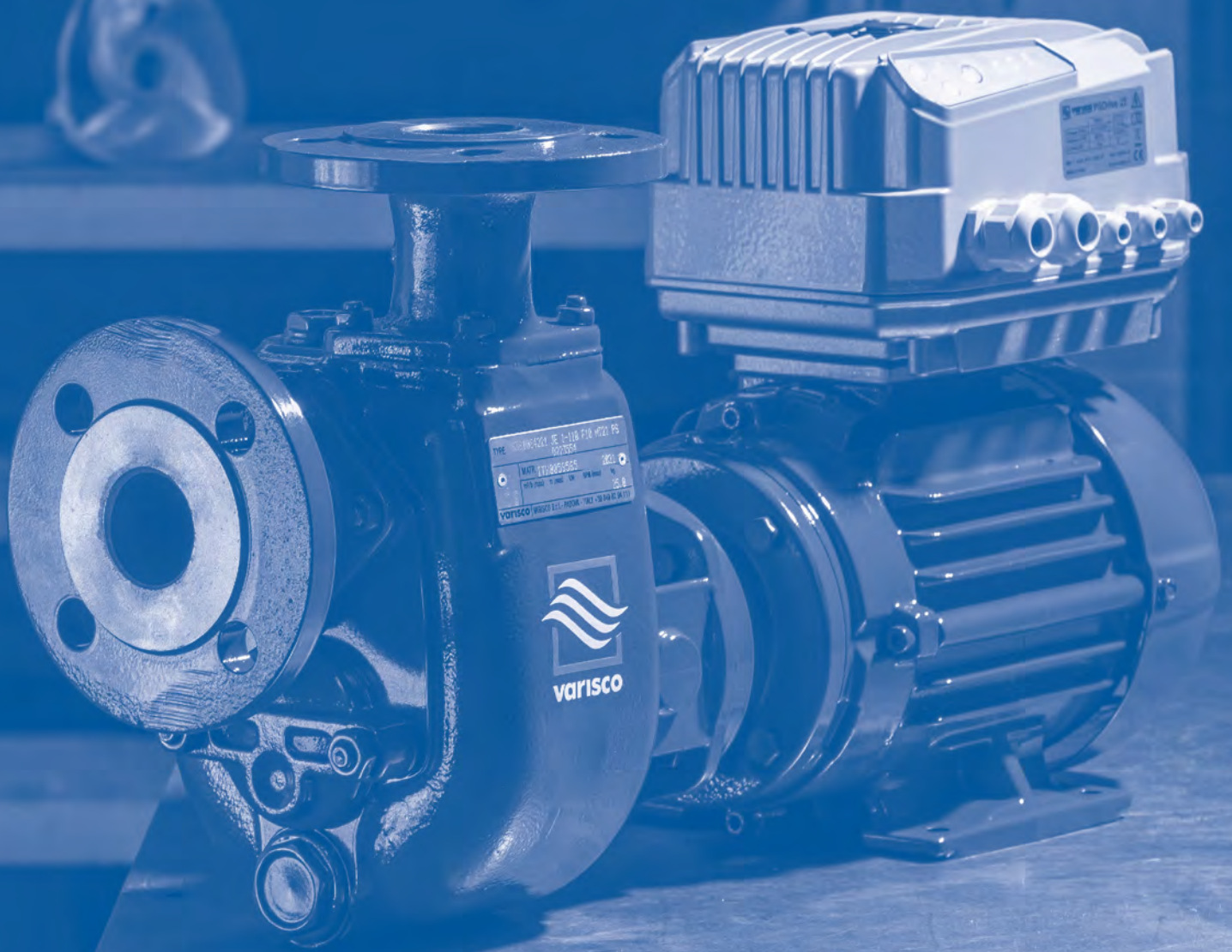

Technical specifications

Model	Vin ± 15% VAC	Max V out VAC	Max I in A	Max I out A	P2 motor power * kW
PSDrive 11	3 x 380 - 460	3 x Vin	3,7	4	1,1
PSDrive 22	3 x 380 - 460	3 x Vin	5,4	6	2,2
PSDrive 40	3 x 380 - 460	3 x Vin	8	9	4
PSDrive 55	3 x 380 - 460	3 x Vin	13,5	14	5,5
PSDrive 75	3 x 380 - 460	3 x Vin	17,5	18	7,5
PSDrive 110	3 x 380 - 460	3 x Vin	24	25	11
PSDrive 150	3 x 380 - 460	3 x Vin	29	30	15
PSDrive 185	3 x 380 - 460	3 x Vin	36,5	38	18,5
PSDrive 220	3 x 380 - 460	3 x Vin	42	44	22

* Typical motor power. It is recommended to refer to rated motor current when selecting the PSDrive model.

GENERAL CHARACTERISTICS

- > Rated frequency: 50 - 60 Hz (+/- 2%)
- > Ambient temperature: - 10 - 40°C (14 - 104 °F)
- > Max. altitude at rated current: 1000 m
- > Protection degree: IP66 (IP55 when installed on motor with equal features)
- > Settable digital outputs N.O. or N.C.:
 1. Motor run signal
 2. Alarm signal
- > Analog inputs (10 or 15 VDC):
 1. 4-20 mA 3. 0 - 10 VDC
 2. 4-20 mA 4. 0 - 10 VDC
- > 4 digital inputs, configurable N.O. or N.C. for motor run/stop
- > RS485 MODBUS RTU, Bluetooth® SMART* (4.0)

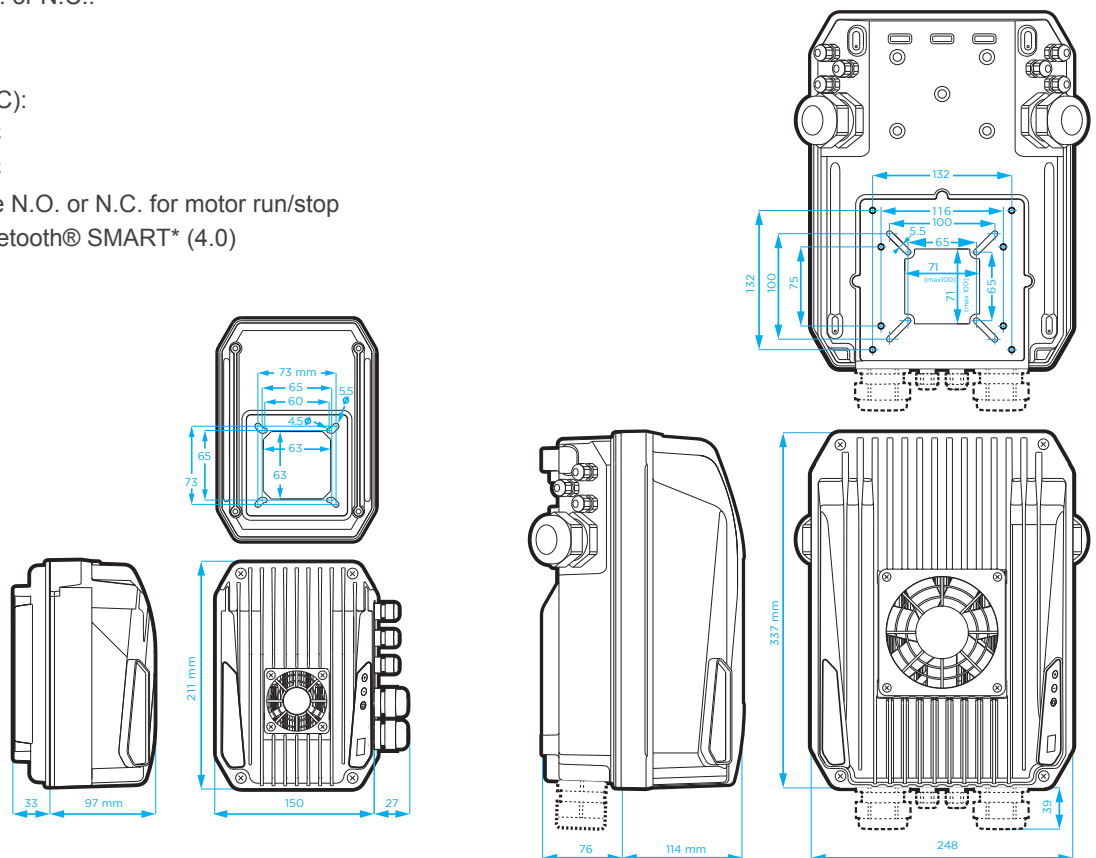

The electromagnetic compatibility (EMC) Directive 2014/30/EU ensures that electrical and electronic equipment does not generate, or is not affected by, electromagnetic disturbance.

